

Installation Instructions

SELECTRONIC® DC POWERED PROXIMITY EXPOSED URINAL FLUSH VALVE 0.125, 0.25, 0.5 & 1.0 GPF

MODEL NUMBERS		
6063.013	6064.013	6062.601
6063.025	6064.025	6063.505
6063.051	6064.051	6063.510
6063.101	6064.101	6063.513



Exposed Flushometer for 3/4" Top Spud Urinals

CLOG RESISTANT

- Self-cleaning piston valve prevents clogging and reduces maintenance.

ONE SENSOR FITS ALL

- Only 1 sensor for entire Selectronic™ line of faucets, urinals, and flush valves.
- Range can be adjusted manually or with optional remote control.
- Sensor Features Low Battery Indicator.

Certified to comply with ASME A112.19.2
© 2014 AS America, Inc.

M965647 REV. 1.1 (12/14)

American Standard

NOTE TO INSTALLER: Please give this manual to the customer after installation.

To learn more about American Standard Selectronic® Products visit our website at: www.americanstandard-us.com
or e-mail us at: CRTTEAM@americanstandard.com

For Parts, Service, Warranty or other Assistance,
please call (844) CRT-TEAM / (844) 278-8326 (In Canada: 1-800-387-0369)
(In Toronto Area only: 1-905-306-1093)

American Standard
CRT
Certified Response Technician

Thank you for selecting American-Standard...the benchmark of fine quality for over 100 years. To ensure that your installation proceeds smoothly--please read these instructions carefully before you begin.

UNPACKING All American Standard Products Are Water Tested At Our Factory. Some Residual Water May Remain In The Valve During Shipping.

Remove the Flush Valve items from the carton. The illustration below shows all items after they have been removed from the carton. Some items may be packaged partially assembled to other items.

- | | |
|----------------------------------|--------------------|
| 1. Installation Instructions | 5. Spud Flange |
| 2. Flush Valve Body Assembly | 6. Wall Escutcheon |
| 3. Vacuum Breaker Tube | 7. Cover Tube |
| 4. Spud Coupling Nut and Washers | 8. Sweat Adapter |
| | 9. Stop Valve |

CARE INSTRUCTIONS:
DO: CLEAN THE PRODUCT WITH CLEAR WATER. DRY WITH A SOFT COTTON FLANNEL CLOTH.
DO NOT: DO NOT CLEAN THE PRODUCT WITH SOAPS, ACID, POLISH, ABRASIVES, HARSH CLEANERS, OR A CLOTH WITH A COARSE SURFACE.

DO NOT REMOVE PROTECTIVE FILM FROM SENSOR EYE UNTIL INSTALLATION IS COMPLETE.

3

4

5

Installation Instructions

SELECTRONIC®
DC POWERED PROXIMITY EXPOSED
URINAL FLUSH VALVE
0.125, 0.25, 0.5 & 1.0 GPF

MODEL NUMBERS		
6063.013	6064.013	6062.601
6063.025	6064.025	6063.505
6063.051	6064.051	6063.510
6063.101	6064.101	6063.513

Exposed Flushometer for 3/4" Top Spud Urinals
CLOG RESISTANT
Self-cleaning piston valve prevents clogging and reduces maintenance.

ONE SENSOR FITS ALL
Only 1 sensor for entire Selectronic™ line of faucets, urinals, and flush valves.
Range can be adjusted manually or with optional remote control.
Sensor Features Low Battery Indicator.

© 2014 AS America, Inc.
M965647 REV. 1.1 (12/14)

American Standard

NOTE TO INSTALLER: Please give this manual to the customer after installation.
To learn more about American Standard Selectronic® Products visit our website at: www.americanstandard-us.com or e-mail us at: CRTEAM@americanstandard.com

For Parts, Service, Warranty or other Assistance, please call (844) CRT-TEAM / (844) 278-8325 (In Canada: 1-800-387-0369) (In Toronto Area only: 1-905-306-1093)

Fig. 1
Roughing-in Dimensions

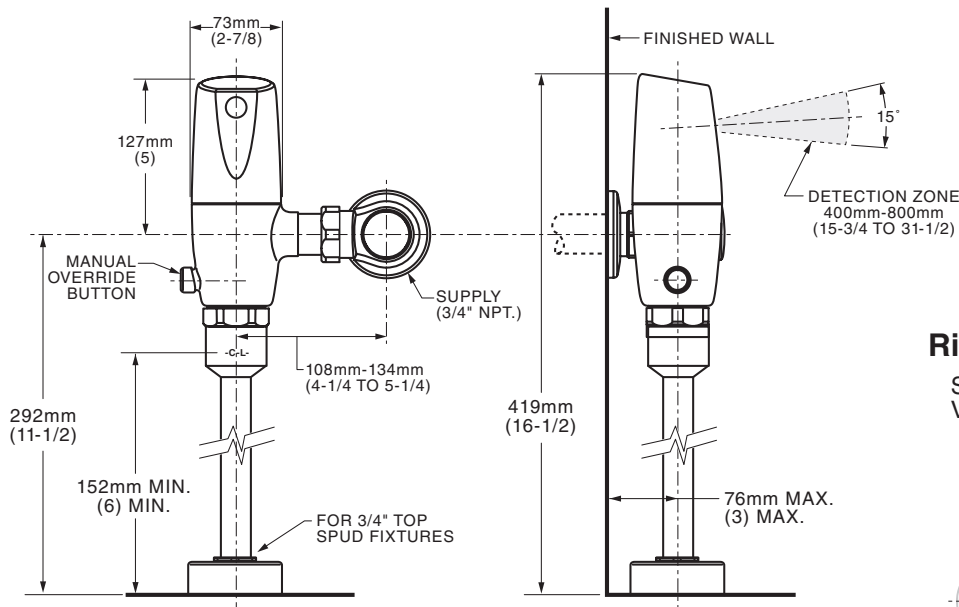

*Note: The Critical Line (-C-L-) on Vacuum Breaker must typically be 6" (152mm) above fixture. Consult Codes for details.

GENERAL DESCRIPTION:

**SELECTRONIC™
PROXIMITY URINAL
FLUSH VALVE**

**Exposed Flushometer
for 3/4" Top Spud Fixtures**

Exclusive, self cleaning piston-type flush valve with proximity operation and manual override. Operates on DC (battery) power. Recommended operating pressure 35 to 80 psi. Can install left or right-handed. Detection Zone can also be adjusted manually, or with optional remote control.

Valve is designed to provide stated flush volume with a 10 GPM flow rate.

Right or Left Hand Installation

See (Section 5) for converting Flush Valve to Left Hand Installation.

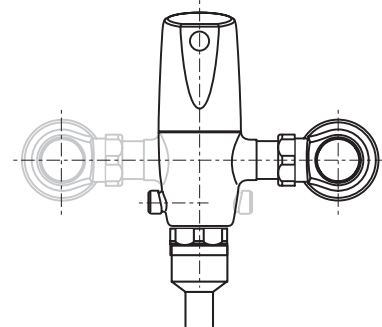

RECOMMENDED TOOLS; Fig. 2

1. Teflon Tape
2. Flat Blade Screwdriver (For adjusting Supply Stop)
3. Adjustable Wrench
4. Tape Measure
5. Hacksaw
6. Tubing Cutter
7. File
8. For Sweat Connection; Solder and Torch
9. 2.5mm Hex Wrench
10. 1.5mm Hex Wrench

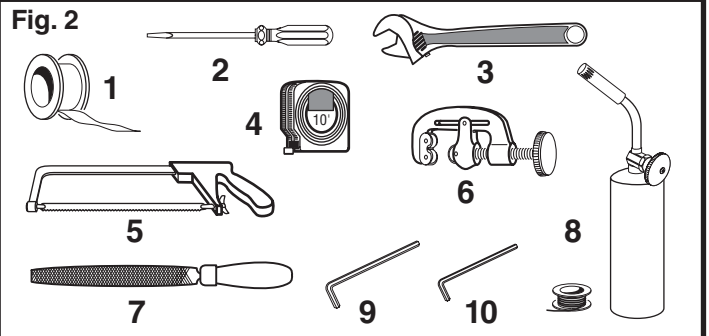

PRIOR TO INSTALLATION

Note: Prior to installing the Selectronic™ Flush Valve the following items must be installed.

1. Urinal
2. Drain line
3. Water supply line

IMPORTANT:

- All plumbing and electrical wiring must be installed in accordance with applicable codes, regulations and standards.
- The use of water hammer arrestors is strongly recommended for commercial applications. All piping behind the walls should be properly secured and fastened.
- Water supply lines must be sized to provide an adequate volume of water for each fixture.

- Flush all water lines prior to operation (See Step 4). Dirt and debris can cause flush valve to run continuously.
- **With the exception of Stop Valve Inlet, DO NOT use pipe sealant or plumbing grease on any valve component or coupling!**
- Protect the chrome or special finish on the Flushometer. DO NOT USE toothed tools on finished surfaces to install or service these valves. Also see "Care and Cleaning" section of this manual.
- This product contains mechanical and/or electrical components that are subject to normal wear. These components should be checked on a regular basis and replaced as needed to maintain the valve's performance.

FLUSH VALVE INSTALLATION

1 INSTALL SWEAT ADAPTER; Fig. 3

CAUTION Turn water supplies off before beginning

Note: *Install Optional Sweat Adapter (Supplied) for copper pipe supply line.*

1. Measure the distance (A) from the finished wall to the center of the inlet spud on the fixture.
2. Cut the supply pipe 1-1/4" (A-B=C) shorter than the measurement taken in Step 1. File any rough edges off the end of the supply pipe.
3. Clean the end of the supply pipe. Push the threaded Adapter until it is seated against the internal stop. Sweat the Adapter to the pipe.

Fig.3

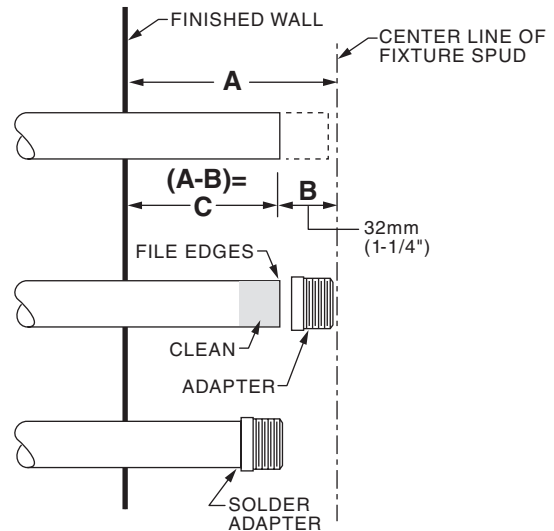

2 INSTALL COVER TUBE, WALL ESCUTCHEON and STOP VALVE; Fig. 4

1. Measure from finished wall to first thread of Adapter or threaded supply pipe (dimension "X"). Cut COVER TUBE (1) to length (X). Apply Teflon Tape to the threaded end of the Adapter or supply pipe.
2. Push WALL ESCUTCHEON (2) onto the COVER TUBE (1). Slide both onto the SUPPLY PIPE (3).
3. Push the COVER TUBE (1) in to expose the threads of the supply pipe. With a wrench thread the STOP VALVE (4) onto the SUPPLY PIPE (3). Align and tighten.
4. Pull COVER TUBE (1) against STOP VALVE (4) and push WALL ESCUTCHEON (2) against finished wall.

Fig. 4

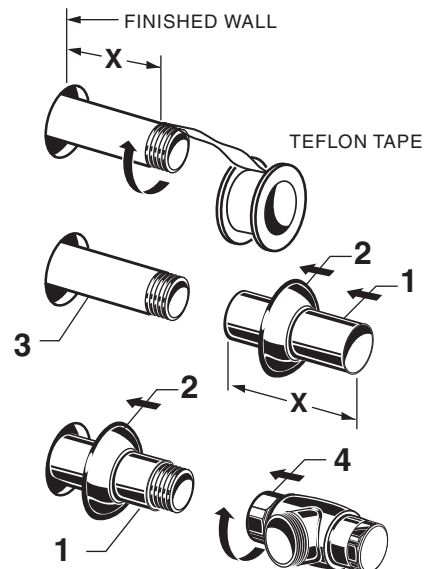

3 INSTALL VACUUM BREAKER TUBE; Fig. 5

1. Place the SPUD FLANGE (1) over the spud on the Fixture.
2. Place FRICTION WASHER (3) and SEAL WASHER (4) inside SPUD COUPLING NUT (2) and thread onto Spud. Do not tighten fully.
3. Insert the VACUUM BREAKER TUBE (5) into the SPUD COUPLING NUT (2) and push it down.

Note: *If cutting VACUUM BREAKER TUBE (5) to size, note that Critical Line (C/L) on Vacuum Breaker must typically be 6" (152mm) above fixture. Consult Code for details.*

Fig. 5

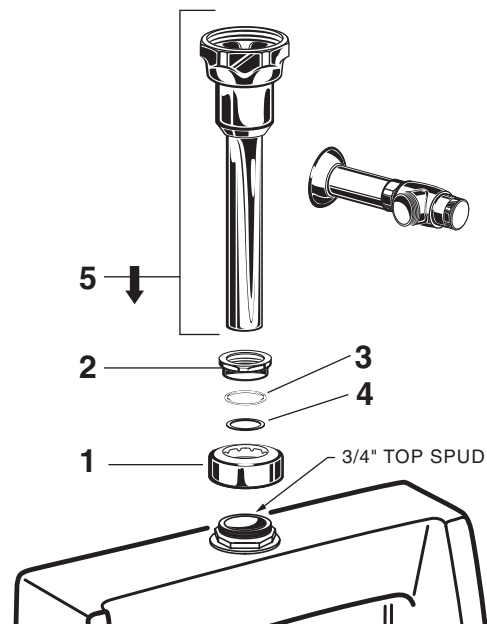

4 FLUSH OUT SUPPLY LINES; Fig. 6

1. Remove STOP VALVE COVER (1) from STOP VALVE (2).
2. Open STOP VALVE (2) with a flat blade screwdriver.
3. Turn on water supply to flush line of any debris or sediment.
4. Close STOP VALVE (2) and replace STOP VALVE COVER (1).

Fig. 6

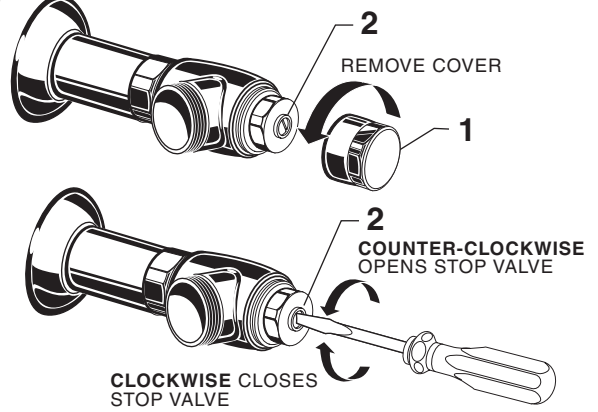

5 LEFT OR RIGHT HAND INSTALLATION; Fig. 7

The unit is shipped with adjustable tailpiece on the right side. If needed, the orientation can be modified by following the steps below.

1. Loosen SET SCREW (1) with 2.5mm Hex Wrench (4) in back of FLUSH VALVE COVER (2).
2. Rotate FLUSH VALVE COVER (2) to the right and pull off.
3. Rotate FLUSH VALVE BODY (3) 180°
4. Replace COVER (2) and rotate until key engages. Tighten SET SCREW (1).

Fig. 7

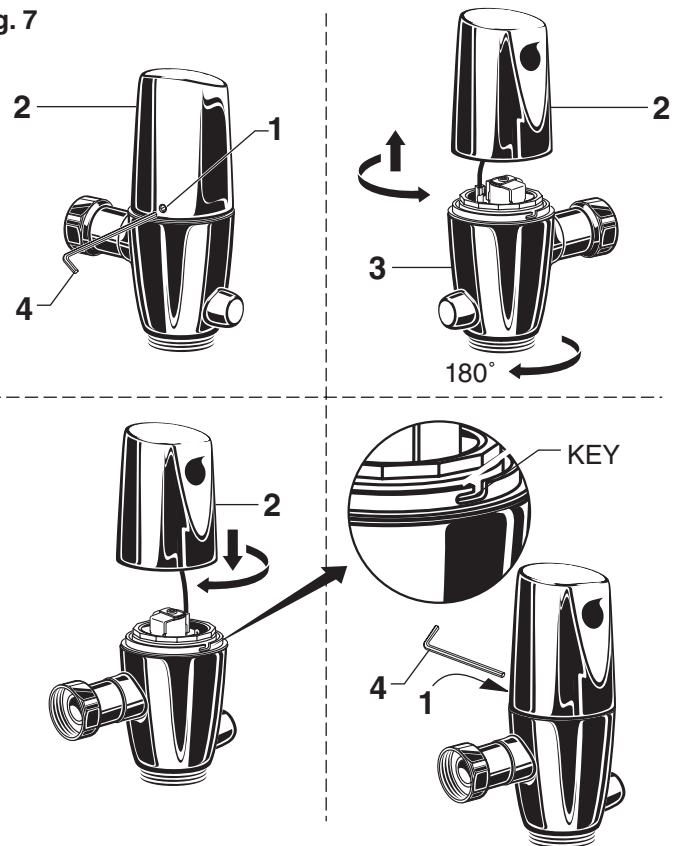

6 INSTALL FLUSH VALVE; Fig. 8, 8a

1. Insert ADJUSTABLE TAILPIECE (1) into the STOP VALVE (2). Lubricate the O-RING (3) with water if necessary. Lightly tighten COUPLING NUT (4). Fig. 8.

Important: Do not use lubricants (other than water) or any type of thread sealing paste or tape.

2. Align the FLUSH VALVE BODY (5) directly above the VACUUM BREAKER TUBE (7) and VACUUM BREAKER COUPLING NUT (6). Fig. 8a.

Note: There is a +13mm, -6mm (+1/2, -1/4) tolerance for the 121mm (4-3/4) dimension. Fig. 8a.

3. Pull the VACUUM BREAKER TUBE (7) up to meet the threaded FLUSH VALVE BODY (5), hand tighten the VACUUM BREAKER COUPLING NUT (6). Align all components of the flush valve assembly. Fig. 8a.

4. Lightly tighten the COUPLING NUT (4) connection first, then the VACUUM BREAKER COUPLING NUT (6) and finally the SPUD COUPLING NUT (8). Once aligned correctly, use a wrench to tighten couplings to make water tight connections. Fig. 8a.

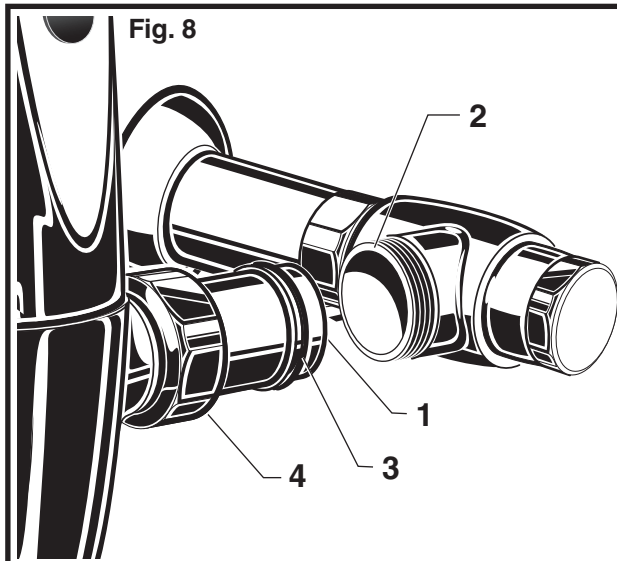
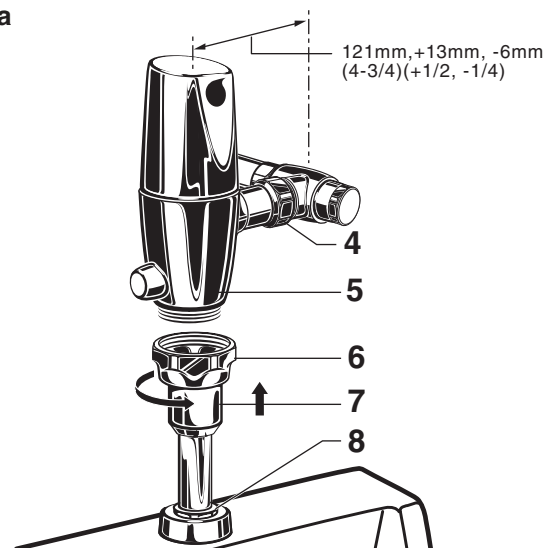

Fig. 8a



MAINTENANCE

A ADJUST STOP VALVE; Fig. 9

IMPORTANT: To avoid overflowing, the STOP VALVE (3) must never be opened to the point where the flow from the valve exceeds the flow capacity of the fixture.

1. After installation is complete, peel off the PROTECTIVE FILM (1) from the sensor. Standing to one side, block the sensor with your hand for 10 seconds. Remove your hand and listen for audible “click” from within the valve.

2. Remove STOP VALVE COVER (2) from STOP VALVE (3). Turn on water supply 1/4 turn to 1/2 turn (CCW) and test for leaks.

Note: Unit may flush for approximately 5 to 10 sec. when water is first turned on. If flow persists, turn water off and repeat step #1 above.

3. Actuate the FLUSH VALVE:
A) Cover sensor with hand for 10 seconds.

NOTE: Stand outside of sensor detection area.

B) Remove hand from in front of the sensor; unit will flush in approximately 3 seconds.

4. Adjust STOP VALVE (3) after each flush until the stated flush volume is achieved, no splashing occurs and the fixture is properly cleansed.

5. When adjustment is complete, replace STOP VALVE COVER (2) and tighten to ensure vandal-resistance.

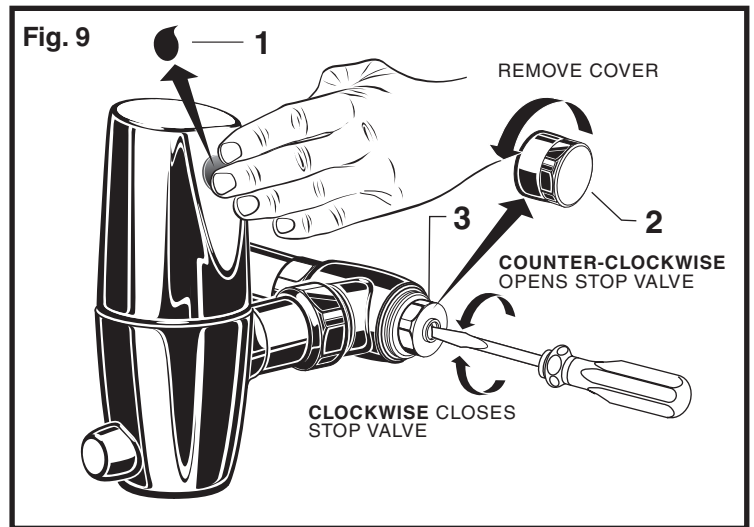

B RETROFITTING WITH SELECTRONIC VALVE; Fig. 10

(Replaces Industry Standard Manual and Electronic Valves)

Note: In most Retrofits the wall escutcheon, stop valve, cover tube and vacuum breaker do not have to be replaced. If these items do need replacement they must be purchased separately or order the complete flush valve assembly from American Standard.

1. Remove STOP VALVE COVER (1) from STOP VALVE (2).

2. Turn water supply off.

3. Loosen SPUD COUPLING NUT (3). Unthread COUPLING NUT (4) and VACUUM BREAKER COUPLING NUT (5). Remove FLUSH VALVE (6).

4. Clean all threaded connections before installing the new flush valve.

5. Refer to Sections 4, 5 and 6 to complete the retrofit installation.

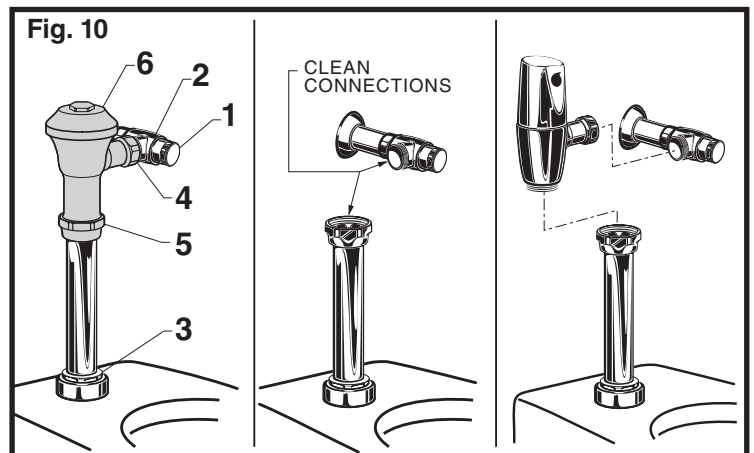

G REPLACE BATTERY; Fig. 11, 11a

1. Loosen SET SCREW (1) with 2.5mm Hex Wrench (2) in back of FLUSH VALVE COVER (3). Fig. 11.
2. Rotate COVER (3) to the right and pull off. Fig. 11.
3. Turn COVER (3) over and disconnect the SENSOR (4) from the BATTERY HOLDER (5). Remove the BATTERY CONTAINER (6) with BATTERY HOLDER (5) and BATTERY (7) inside. Fig. 11a.
4. Remove BATTERY HOLDER (5) from BATTERY CONTAINER (6). Fig. 11a.
5. Remove old BATTERY from BATTERY HOLDER (5). Install the new BATTERY (7) making sure the shape of the BATTERY follows the shape of the BATTERY HOLDER (5). Fig. 11a.
6. Insert BATTERY HOLDER (5) with BATTERY into BATTERY CONTAINER (6). Insert BATTERY CONTAINER (6) into flush valve COVER (3). Fig. 11a
7. Connect BATTERY HOLDER (5) to SENSOR (4) and reverse the above steps to assemble flush valve. Fig. 11a.

D REPLACE LONG LIFE POWER PACK; Fig. 11, 11b

1. Loosen SET SCREW (1) with 2.5mm Hex Wrench (2) in back of FLUSH VALVE COVER (3). Fig. 11.
2. Rotate COVER (3) to the right and pull off. Fig. 11.
3. Turn COVER (3) over and disconnect SENSOR (4) from LONG LIFE POWER PACK (8). Fig. 11b.
4. Remove old LONG LIFE POWER PACK (8) and insert new unit. Fig. 11b.
5. Connect new LONG LIFE POWER PACK (8) to SENSOR (4). Reverse the above steps to assemble flush valve. Fig. 11b.

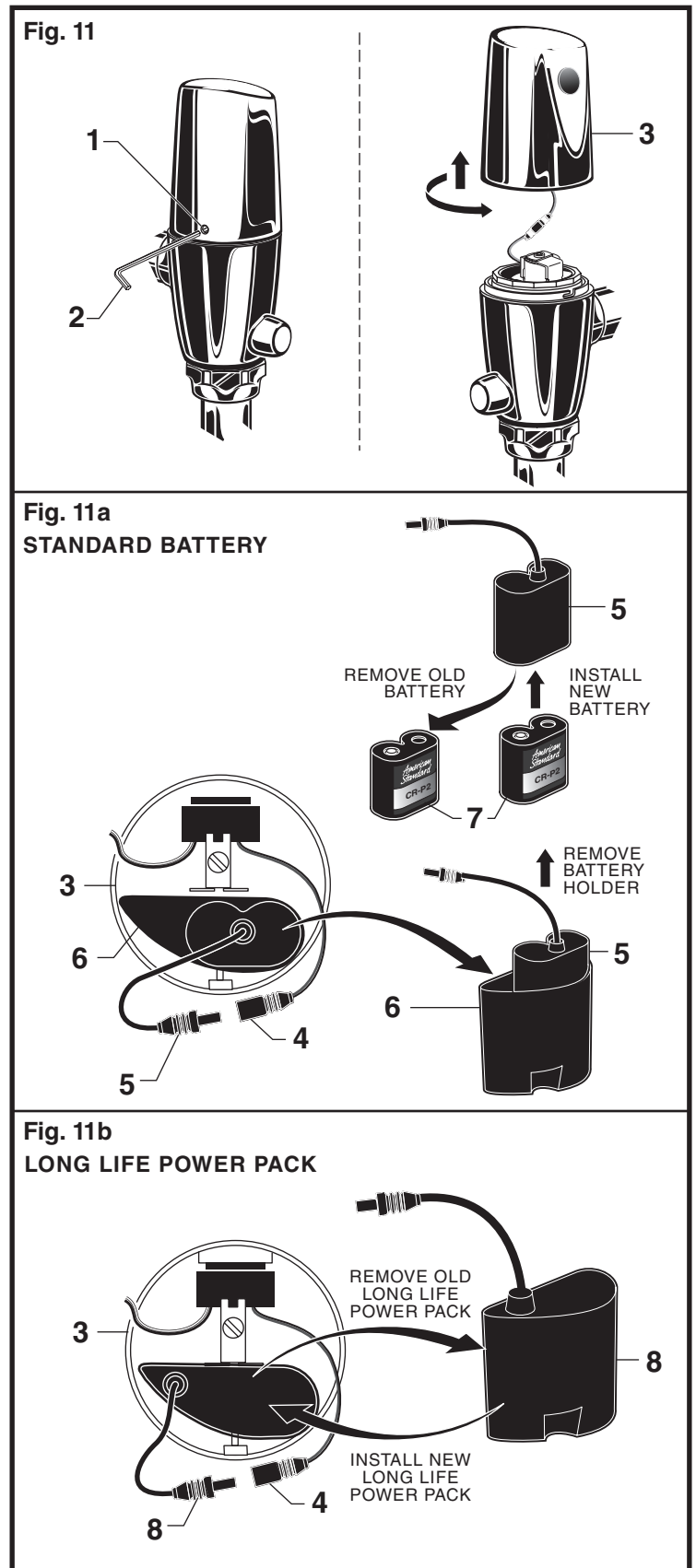

SET DETECTION RANGE (If Required); Fig. 13 & 14

Note: *The detection distance is preset and ideal for most installations. Should an adjustment be required, follow the steps below.*

1. Loosen SET SCREW (1) with 2.5mm Hex Wrench (2) in back of FLUSH VALVE COVER (3). Fig. 13a.
2. Rotate COVER (3) to the right and pull off. Fig. 13b.
3. Turn COVER (3) over and disconnect CABLE (4) from BATTERY HOLDER (5). Fig. 13.

4. Keeping hands away from the sensor detection area, reconnect the SENSOR (4) and quickly place the COVER (3) on the valve. Do not secure the COVER (3) at this time.

Note: *You have 5 seconds to begin entering the program code after power connection is made.*

5. While the SENSOR CONTROL LED (1) is blinking slowly, place your hand 1 to 2 in. (30-50mm.) in front of the sensor. Fig. 14.

6. When the LED (1) stops blinking and stays "ON", move your hand to the desired position and hold in place until the LED (1) begins to blink again. Fig. 14.

Note: *Detection Zone is 400mm - 800mm. (Factory Setting: 400mm)*

7. Once the SENSOR CONTROL LED (1) begins to blink again, remove your hand from the detection zone. When the flashing stops, the detection distance is set.

8. Replace and secure COVER (3) onto valve.

9. Actuate the FLUSH VALVE:
A) Cover sensor with hand for 10 seconds.

NOTE: Stand outside of sensor detection area.

B) Remove hand from in front of the sensor; unit will flush in approximately 3 seconds.

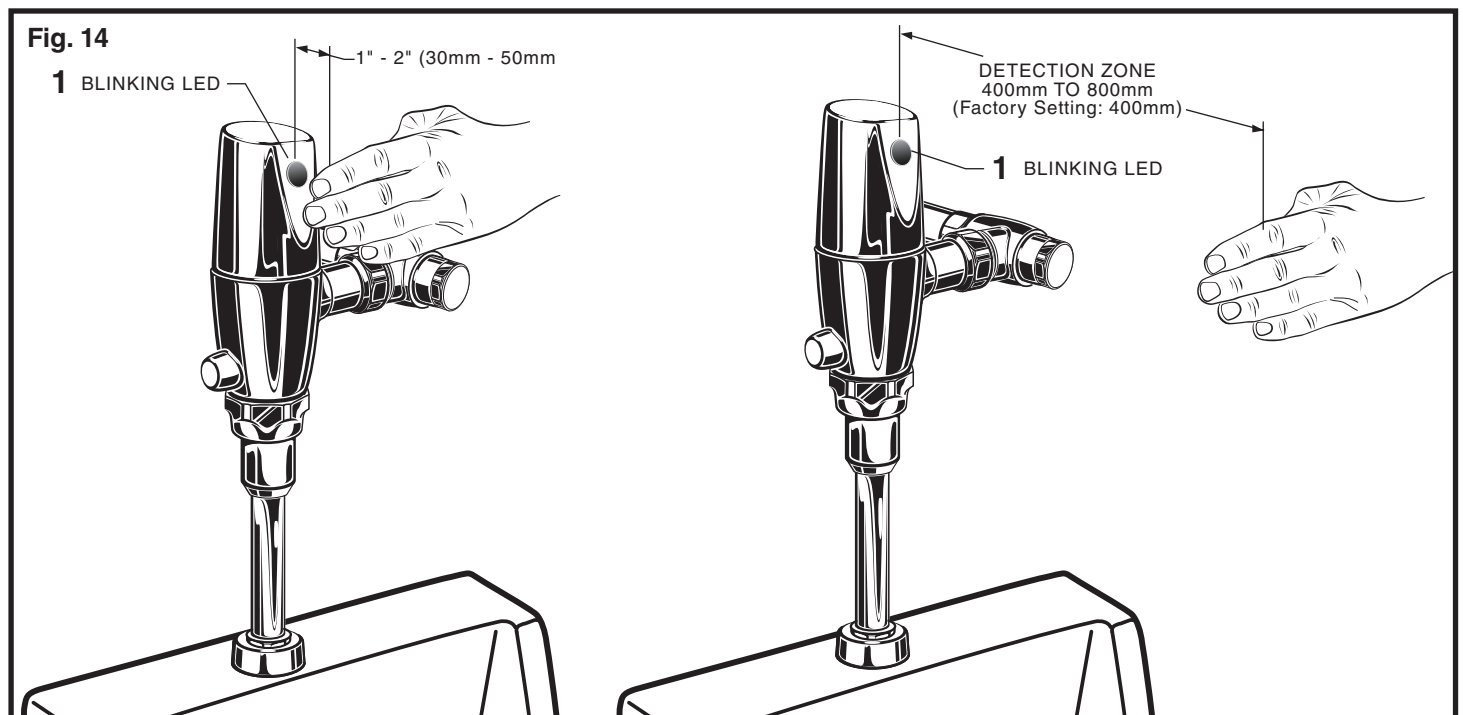
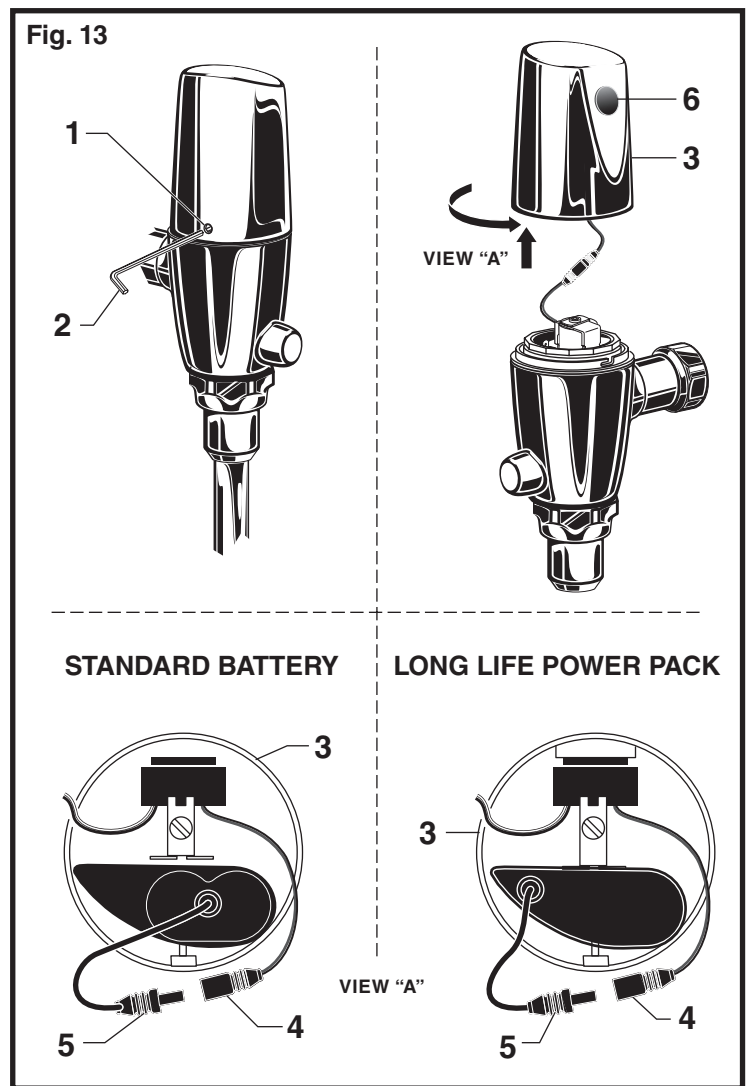

TROUBLESHOOTING FLOW CHARTS

UNIT DOES NOT FUNCTION

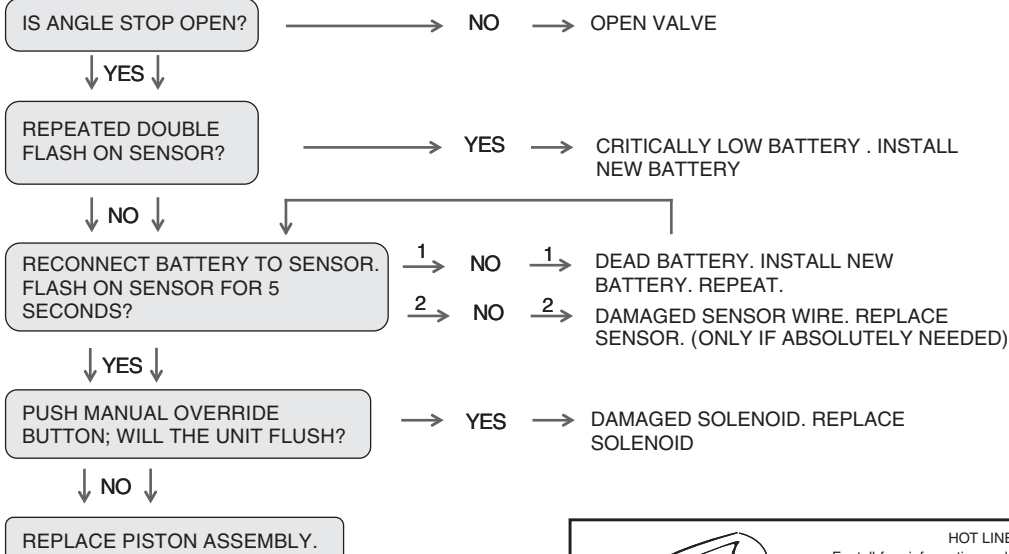

UNIT WILL ONLY FLUSH MANUALLY

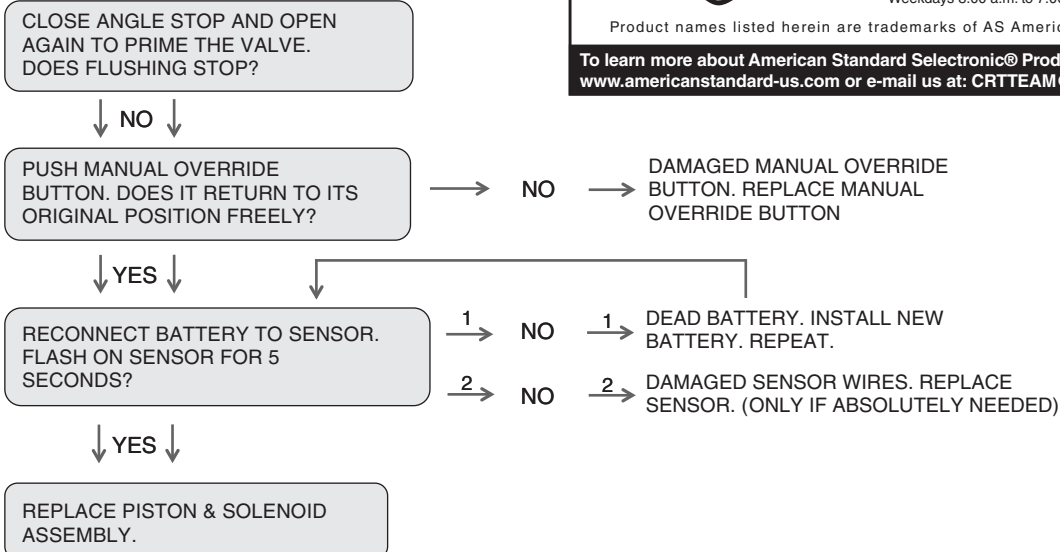

UNIT IS CONTINUOUSLY FLUSHING

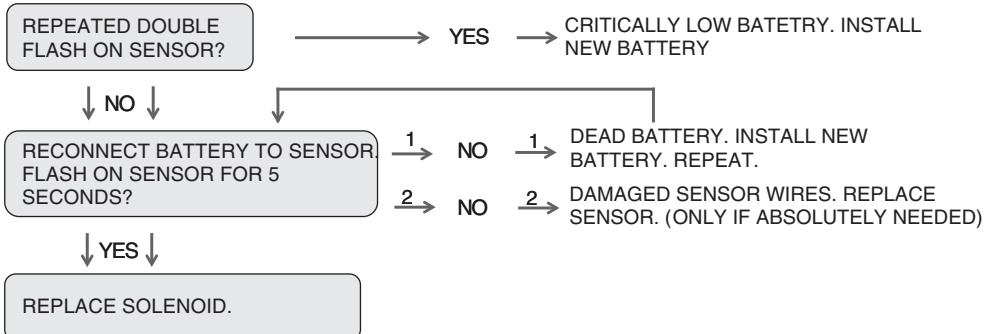

HOT LINE FOR HELP
 For toll-free information and answers to your questions, call:
 (844) CRT-TEAM / (844) 278-8326
 Weekdays 8:00 a.m. to 6:00 p.m. EST
 IN MEXICO 01-800-839-1200
 IN CANADA 1-800-387-0369 (TORONTO 1-905-306-1093)
 Weekdays 8:00 a.m. to 7:00 p.m. EST

Product names listed herein are trademarks of AS America, Inc. ©2014

To learn more about American Standard Selectronic® Products visit our website at: www.americanstandard-us.com or e-mail us at: CRTTEAM@americanstandard.com