

American Standard

CERATHERM

CENTRAL THERMOSTAT
WITH VOLUME CONTROL
TRIM KIT

Installation Instructions T203.740

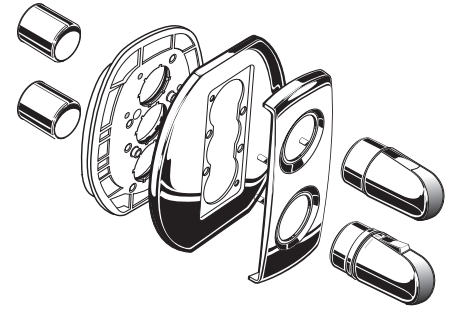

Thank you for selecting American-Standard...the benchmark of fine quality for over 100 years.

To ensure that your installation proceeds smoothly—please read these instructions carefully before you begin.

Certified to comply with ANSI A112.18.1M
ASSE 1016

M968683 REV.1.1

ROUGHING-IN DIMENSIONS

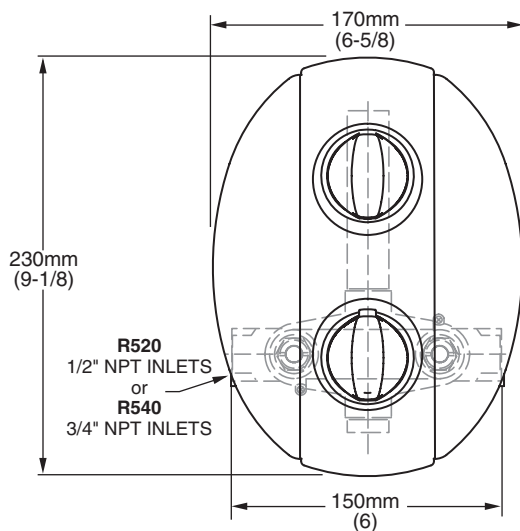

NOTE: FITTING
MUST BE INSTALLED
WITH VOLUME CONTROL
ON TOP.

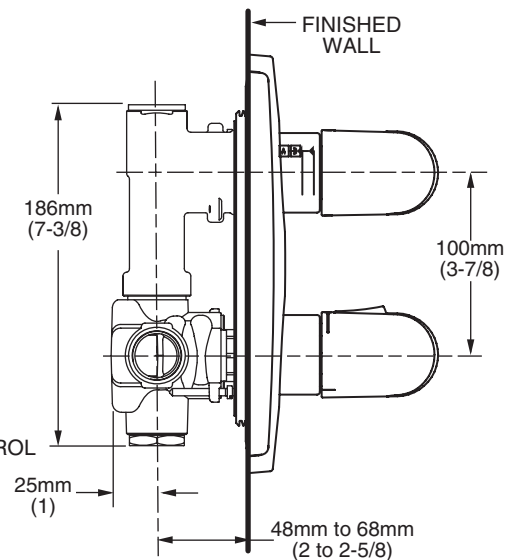

Recommended Tools

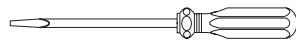

Flat Blade Screwdriver

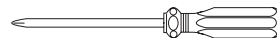

Phillips Screwdriver

CARE INSTRUCTIONS:

- To keep your new faucet looking new, please follow these simple care instructions:
 - DO:**
 - Simply rinse the faucet clean with clear water.
 - Dry the faucet with a soft cotton cloth.
 - DO NOT:**
 - Do not use any abrasive cleaners, cloths, or paper towels.
 - Do not use any cleaning agents containing acids, polish abrasives, or harsh cleaners or soaps.
- Regular and routine cleaning will reduce the need for heavy cleaning and polishing. If heavy cleaning is required, the following procedures are recommended:

- Remove as much surface dirt and film using clear water and soft cotton cloth (as described above).
 - Use any of the following to remove tough surface film and build-up:
 - Mild liquid detergents
 - Clear ammonia free liquid glass cleaners
 - Non-acidic, non-abrasive gentle liquid or fully dissolved powder cleansers mixed according to manufacturers directions.
 - Non-abrasive liquid polishers
- Once clean, rinse faucet again with clear water to thoroughly remove cleaner or polish and blot dry with a soft cotton cloth.

Failure to follow these care instructions may damage the Faucet's finish.

1 TRIM INSTALLATION

- Remove PLASTER GUARD **(1)** if attached.

Push CAPS **(2 & 2a)** as shown onto CONTROL VALVES **(4)**.

Push ESCUTCHEON HOLDER **(3)** with lightly greased O-RING SEALS **(5)** over CAPS **(2, 2a)**. Attach with the two LONG SCREWS **(6)** provided.

Attach ESCUTCHEON **(7)** to ESCUTCHEON HOLDER **(3)** with the two SHORT SCREWS **(8)** provided.

Align pins in back of DIAL PLATE **(9)** with holes in ESCUTCHEON **(5)** and push DIAL PLATE **(9)** into place.

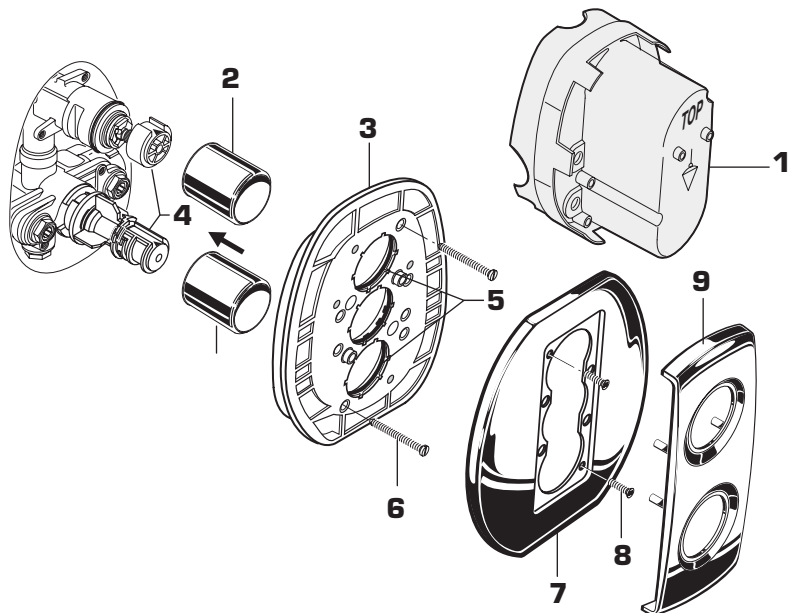

2 INSTALL HANDLES

- Push TEMPERATURE-CONTROL KNOB **(1)** (with the red stop button) onto KNOB MOUNT **(2)**.
- Install HANDLE SCREW **(3)** and tighten with screwdriver.
- Push KNOB CAP **(4)** into TEMPERATURE-CONTROL KNOB **(1)**.
- Push VOLUME-CONTROL KNOB **(5)** onto KNOB MOUNT **(6)**.
- Install HANDLE SCREW **(7)** and tighten with screwdriver.
- Push KNOB CAP **(4a)** into VOLUME-CONTROL KNOB **(5)**.

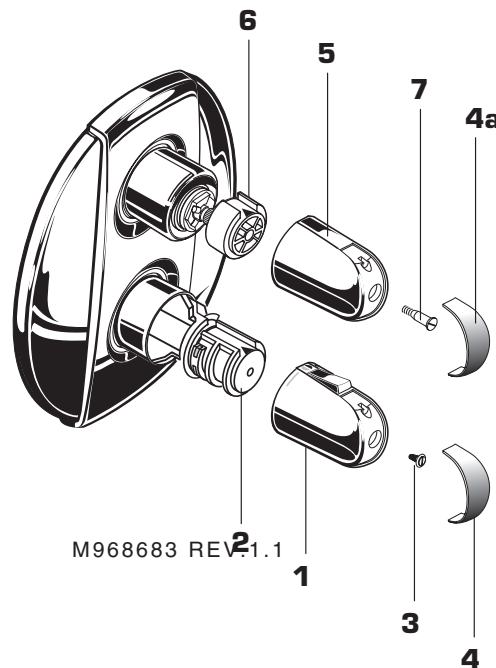

3 TRANSPOSED SUPPLY PIPING OR BACK TO BACK INSTALLATION

Should the hot and cold water supply pipes have been transposed making adjustment impossible, proceed as follows:

- Shut off water supply.
 - Remove handle and rim. **(Reverse steps 1 and 2)**.
 - Remove check stops and re-install them transposed.
- Important note: RED CHECK STOP is now on the right of the mixer body and the BLUE CHECK STOP is now on the left.
- Turn the water supply back on and perform the temperature adjustment in step 4.
- Assemble HANDLES and TRIM.

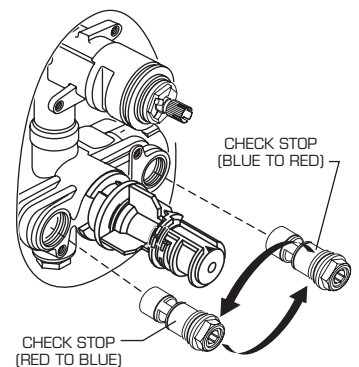

4 TEMPERATURE ADJUSTMENT

- Pull out END CAP (1) and remove HANDLE SCREW (2). Pull off HANDLE ASSEMBLY (3).
- Check that arrow marking B points to the 3 o'clock position. If not, push the BLACK CLAMP on the SECURING RING to the right, pull off KNOB MOUNT (4) and reinstall KNOB MOUNT (4) with arrow "B" 3 o'clock position. See Figure 1.

SET HOT LIMIT STOP

- The maximum mixed water temperature is set at 109°F at the factory. This setting can be changed if desired.
- Remove the TEMPERATURE LIMIT STOP (H shaped Black Plastic part). Reinstall it at the desired notch as indicated in the diagram to limit the maximum mixed water temperature to 104°F or 112°F.
- For 100 F adjustment, turn the water supply on. Turn KNOB MOUNT (4) until the spout temperature is 100°F. Check that arrow "A" on the KNOB MOUNT (4) still points 3 o'clock position after adjusting the thermostat to 100°F. If not, pull out the RED LOCKING DEVICE. Remove KNOB MOUNT (4) by pulling it towards you while standing directly in front of the valve.
- Reinstall the KNOB MOUNT (4) with arrow "A" 3 o'clock position.
- Reinstall RED LOCKING DEVICE.
- See step 3 for HANDLE (3) installation.

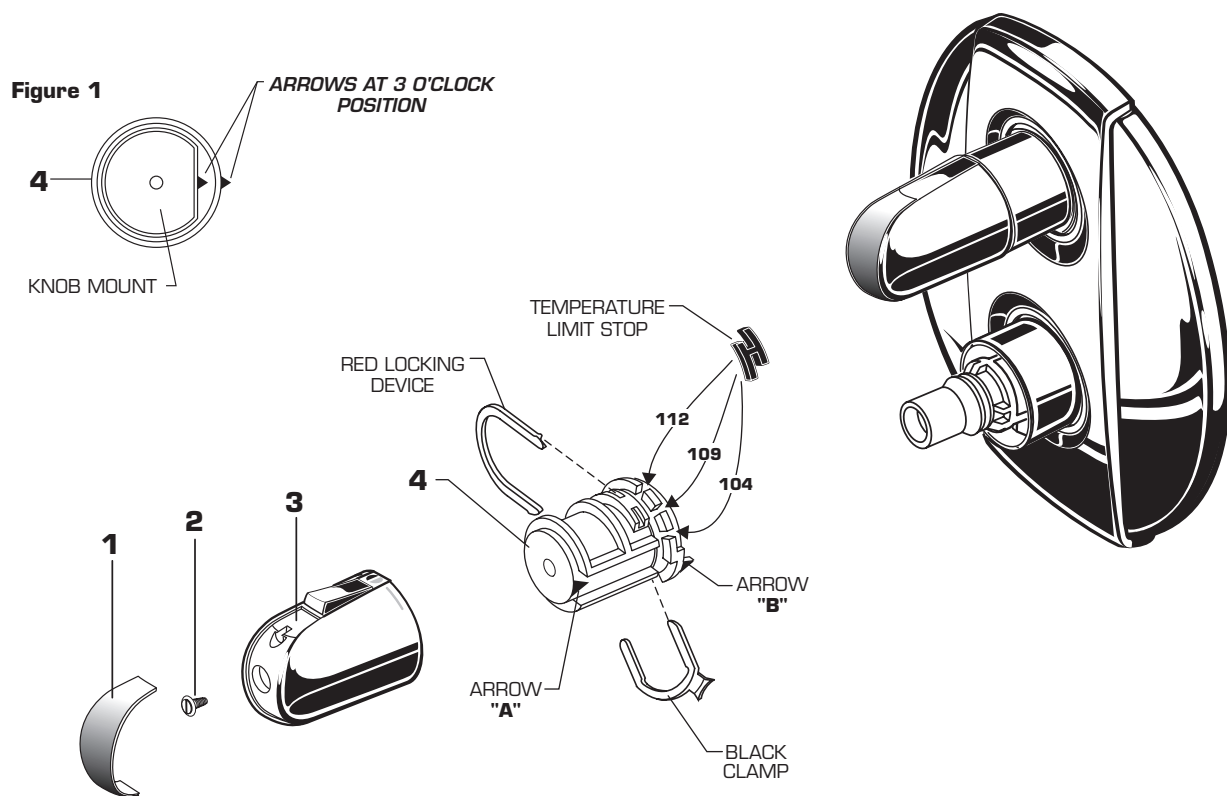

CERATHERM

CENTRAL THERMOSTAT WITH VOLUME CONTROL

Thank you for selecting American-Standard...the benchmark of fine quality for over 100 years.

To ensure that your installation proceeds smoothly—please read these instructions carefully before you begin.

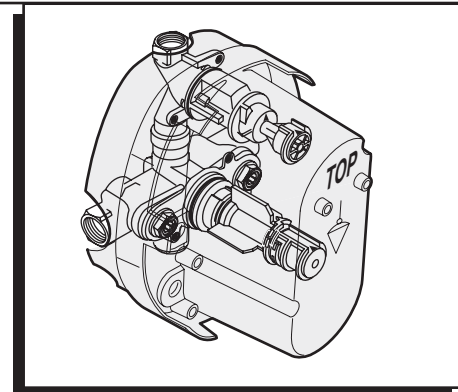

Certified to comply with ANSI A112.18.1M ASSE 1016

M968255Rev.1.1

ROUGHING-IN DIMENSIONS

CONNECTIONS ARE: 1/2" NPT

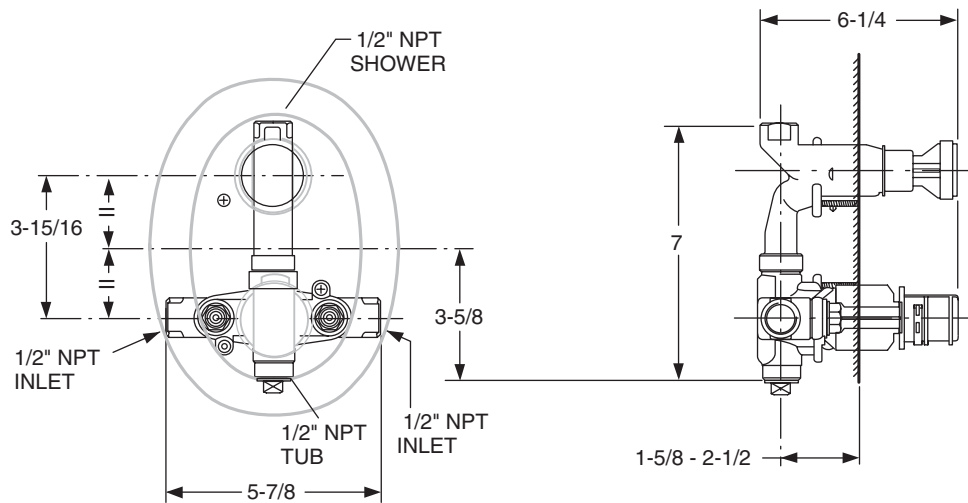

THERMOSTATIC BATH/SHOWER INSTALLATION USING A TWIN ELL, DIVERTER SPOUT AND FIXED SHOWER

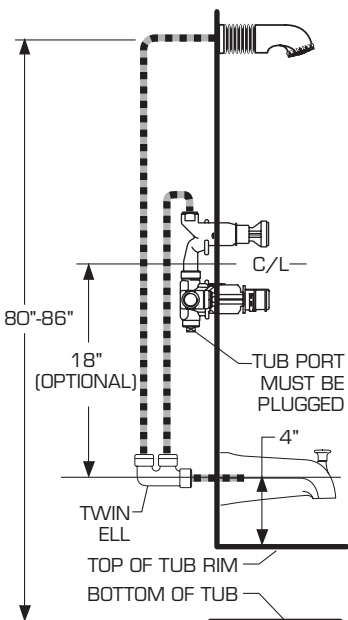

IMPORTANT: WHEN NOT USING A DIVERTER SPOUT A SEPARATE DIVERTER VALVE MUST BE USED.

THERMOSTATIC SHOWER INSTALLATION USING A DIVERTER VALVE, FIXED SHOWER HEAD AND ADJUSTABLE HAND HELD SHOWER

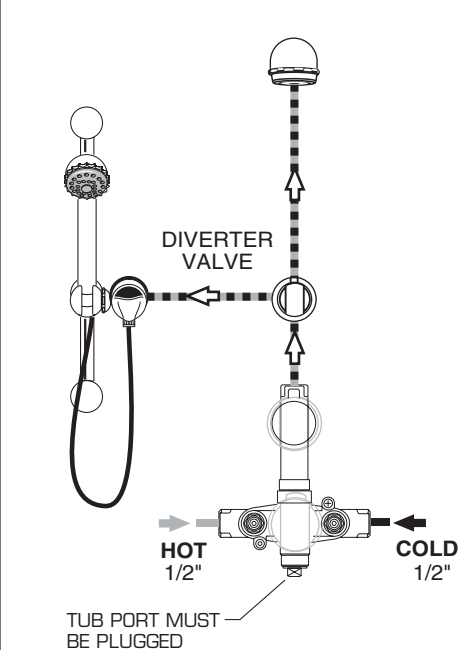

THERMOSTATIC SHOWER INSTALLATION USING A DIVERTER VALVE, FIXED SHOWER HEAD, ADJUSTABLE HAND HELD SHOWER, ON/OFF VALVE AND TWO BODY SPRAYS

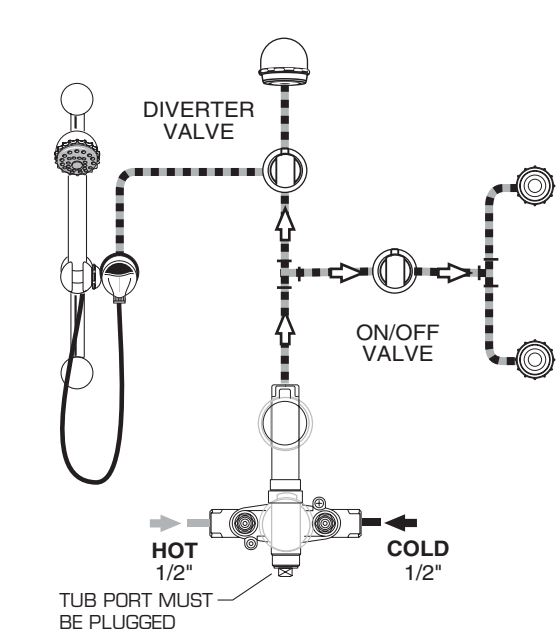

NOTE: MINIMUM FLOWING PRESSURE REQUIRED FOR THIS SYSTEM OPERATING WITH ONE SHOWER HEAD AND 2 BODY SPRAYS IS 40 PSI

1 ROUGHING-IN THE VALVE **WARNING** DO NOT SOLDER DIRECTLY TO THE VALVE BODY; THIS WILL DAMAGE THE TEMPERATURE CONTROL ELEMENT AND CHECK STOP VALVES.

- Prepare water supplies per ROUGHING-IN DIMENSIONS. Make sure the finished wall is between the minimum and maximum rough dimension.
- Install VALVE at indicated height and depth. Make sure the "TOP" marking on the PLASTER GUARD is up.
- Connect the hot and cold water supplies. Assemble all connecting pipes. Flush lines to remove any dirt. Connections are 1/2" NPT.
- Assemble the connection pipe to one of the MIXED OUTLETS of the VALVE. Cap the other MIXED OUTLET. (*Tub port is fitted with a plug at the factory.*)
- IMPORTANT! INSTALL ANY REQUIRED SHUT OFF OR DIVERTER VALVES INTO THE PIPING SYSTEM.
- If the CHECK STOPS (4, 5) were removed during installation, ensure the hot and cold CHECK STOPS (4, 5) are not reversed. The hot CHECK STOP (4) has a red top and the cold CHECK STOP (5) has a blue top.
- CHECK STOPS (4,5) are supplied in the open position. Closing using 5/32" (4 mm) hex wrench to pressure test and to check for leaks.
- To flush lines, remove the CHECK STOPS (4,5) and run water. If desired, the TEMPERATURE CONTROL UNIT can be removed. Reinstall CHECK STOPS (4,5) and CONTROL UNIT (6), if it was removed.
- Remove PLASTER GUARD (2) if still installed. Turn on water supplies and check for leaks.
- Reassemble PLASTER GUARD (2) and FINISH WALL.
- **Beware of Freezing.** No water should remain in the MIXING VALVE if freezing is a possibility. Remove the CHECK STOPS (4,5) to completely drain the MIXER UNIT (1).

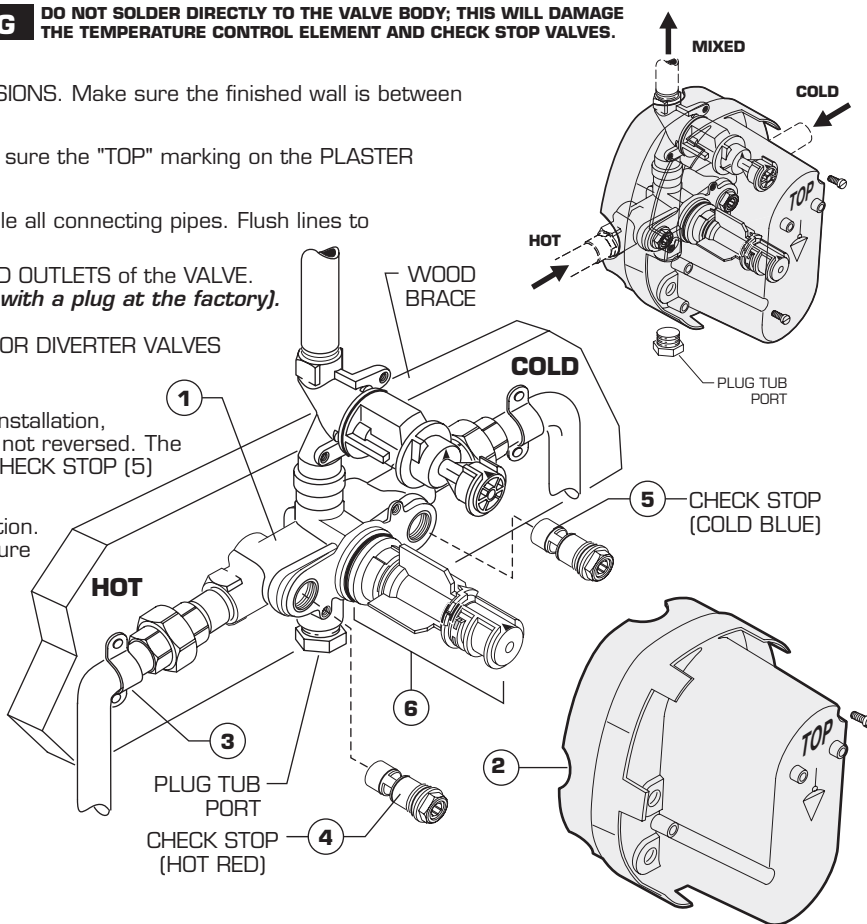

2 TEMPERATURE ADJUSTMENT

- Unscrew PLASTER GUARD SCREWS and remove PLASTER GUARD.
- Check that arrow marking B points vertically upwards. If not, push the BLACK CLAMP on the SECURING RING to the right, pull off KNOB MOUNT and reinstall KNOB MOUNT with arrow "B" pointing upwards.
- The maximum mixed water temperature is set at 109 F at the factory. This setting can be changed if desired.
- Remove the TEMPERATURE LIMIT STOP (H shaped Black Plastic part). Reinstall it at the desired notch as indicated in the diagram to limit the maximum mixed water temperature to 104 F or 112 F.
- For 100 F adjustment, turn the water supply on. Turn KNOB MOUNT until the spout temperature is 100 F. Check that arrow marking A on the KNOB MOUNT still points upward after adjusting the thermostat to 100 F. If not, pull out the RED LOCKING DEVICE. Remove KNOB MOUNT by pulling it towards you while standing directly in front of the valve.
- Reinstall the KNOB MOUNT so that the arrow marking A points upwards.
- Reinstall RED LOCKING DEVICE.

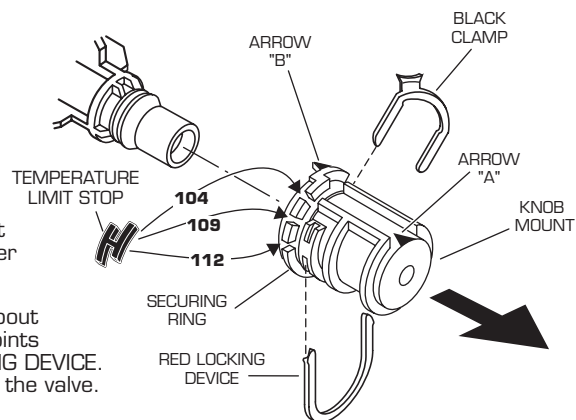

3 TRANSPOSED SUPPLY PIPING OR BACK TO BACK INSTALLATION

Should the hot and cold water supply pipes have been transposed making adjustment impossible, proceed as follows:

- Shut off water supply.
- Remove handle and rim
- Remove check stops and re-install them transposed.
- Important note: RED CHECK STOP is now on the right of the mixer body and the BLUE CHECK STOP is now on the left.
- Turn the water supply back on and perform the temperature adjustment in step 2.

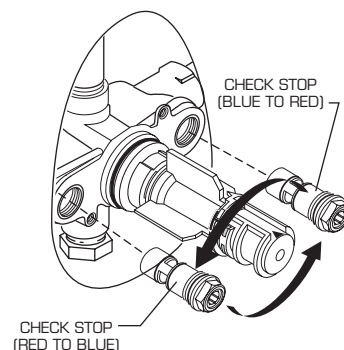

American Standard

Installation Instructions

R540

CERATHERM

3/4" CENTRAL THERMOSTAT WITH VOLUME CONTROL

Thank you for selecting American-Standard...the benchmark of fine quality for over 100 years.

To ensure that your installation proceeds smoothly—please read these instructions carefully before you begin.

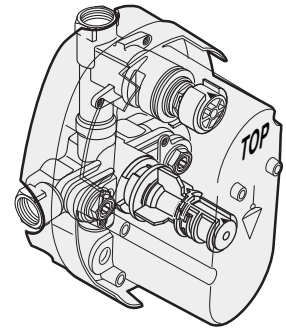

Certified to comply with ANSI A112.18.1M
ASSE 1016

M968480

ROUGHING-IN DIMENSIONS

CONNECTIONS ARE: 3/4" NPT

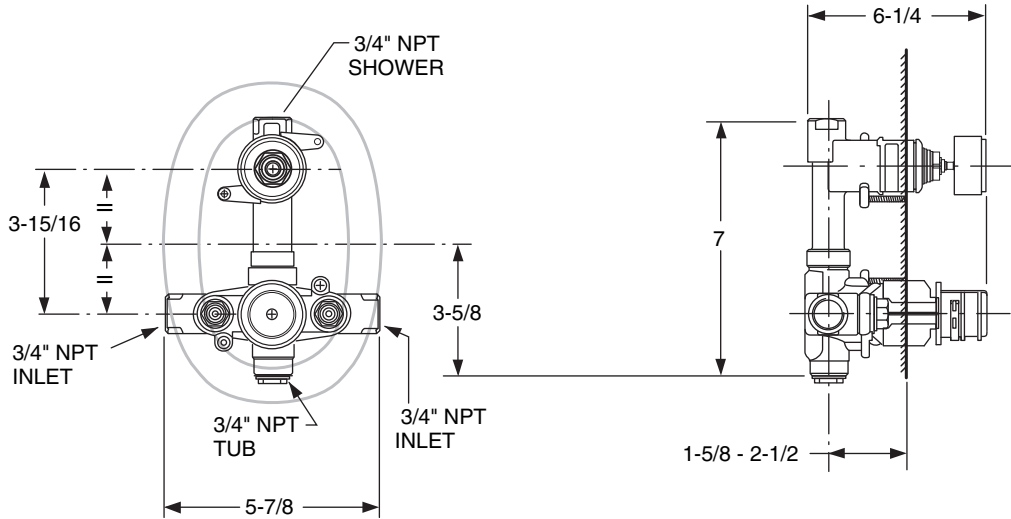

THERMOSTATIC BATH/SHOWER INSTALLATION USING A TWIN ELL, DIVERTER SPOUT AND FIXED SHOWER

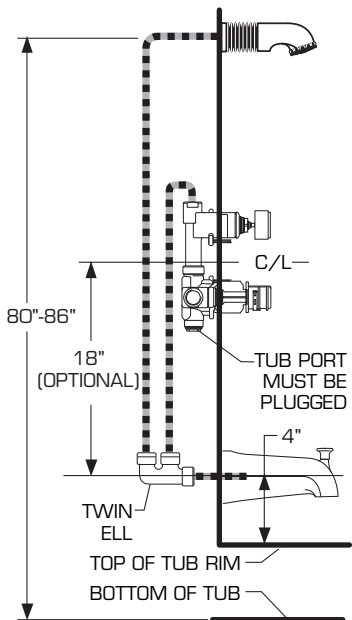

IMPORTANT: WHEN NOT USING A DIVERTER SPOUT A SEPARATE DIVERTER VALVE MUST BE USED.

THERMOSTATIC SHOWER INSTALLATION USING A DIVERTER VALVE, FIXED SHOWER HEAD AND ADJUSTABLE HAND HELD SHOWER

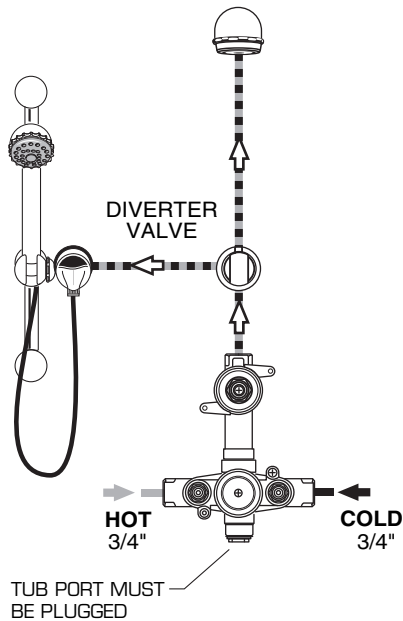

THERMOSTATIC SHOWER INSTALLATION USING A DIVERTER VALVE, FIXED SHOWER HEAD, ADJUSTABLE HAND HELD SHOWER, ON/OFF VALVE AND TWO BODY SPRAYS

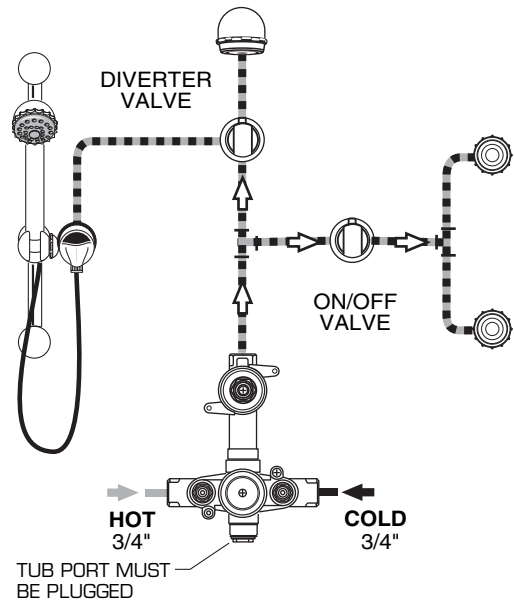

NOTE: MINIMUM FLOWING PRESSURE REQUIRED FOR THIS SYSTEM OPERATING WITH ONE SHOWER HEAD AND 2 BODY SPRAYS IS 40 PSI

1 ROUGHING-IN THE VALVE **WARNING** DO NOT SOLDER DIRECTLY TO THE VALVE BODY; THIS WILL DAMAGE THE TEMPERATURE CONTROL ELEMENT AND CHECK STOP VALVES.

- Prepare water supplies per ROUGHING-IN DIMENSIONS. Make sure the finished wall is between the minimum and maximum rough dimension.
- Install VALVE at indicated height and depth. Make sure the "TOP" marking on the PLASTER GUARD is up.
- Connect the hot and cold water supplies. Assemble all connecting pipes. Flush lines to remove any dirt. Connections are 3/4" NPT.
- Assemble the connection pipe to one of the MIXED OUTLETS of the VALVE. Cap the other MIXED OUTLET. (*Plug port is fitted with a plug at the factory.*)
- IMPORTANT! INSTALL ANY REQUIRED SHUT OFF OR DIVERTER VALVES INTO THE PIPING SYSTEM.
- If the CHECK STOPS (4, 5) were removed during installation, ensure the hot and cold CHECK STOPS (4, 5) are not reversed. The hot CHECK STOP (4) has a red top and the cold CHECK STOP (5) has a blue top.
- CHECK STOPS (4,5) are supplied in the open position. Closing using 5/32" (4 mm) hex wrench to pressure test and to check for leaks.
- To flush lines, remove the CHECK STOPS (4,5) and run water. If desired, the TEMPERATURE CONTROL UNIT can be removed. Reinstall CHECK STOPS (4,5) and CONTROL UNIT (6), if it was removed.
- Remove PLASTER GUARD (2) if still installed. Turn on water supplies and check for leaks.
- Reassemble PLASTER GUARD (2) and FINISH WALL.
- **Beware of Freezing.** No water should remain in the MIXING VALVE if freezing is a possibility. Remove the CHECK STOPS (4,5) to completely drain the MIXER UNIT (1).

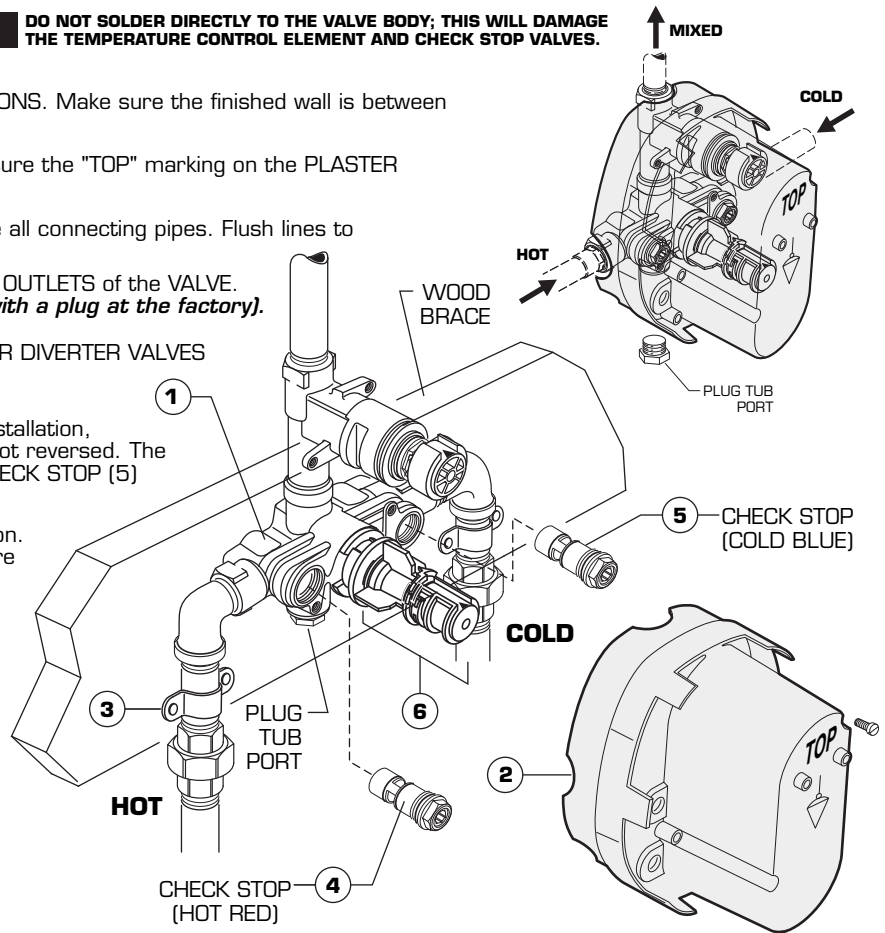

2 TEMPERATURE ADJUSTMENT

- Unscrew PLASTER GUARD SCREWS and remove PLASTER GUARD.
- Check that arrow marking B points vertically upwards. If not, push the BLACK CLAMP on the SECURING RING to the right, pull off KNOB MOUNT and reinstall KNOB MOUNT with arrow "B" pointing upwards.
- The maximum mixed water temperature is set at 109 F at the factory. This setting can be changed if desired.
- Remove the TEMPERATURE LIMIT STOP (H shaped Black Plastic part). Reinstall it at the desired notch as indicated in the diagram to limit the maximum mixed water temperature to 104 F or 112 F.
- For 100 F adjustment, turn the water supply on. Turn KNOB MOUNT until the spout temperature is 100 F. Check that arrow marking A on the KNOB MOUNT still points upward after adjusting the thermostat to 100 F. If not, pull out the RED LOCKING DEVICE. Remove KNOB MOUNT by pulling it towards you while standing directly in front of the valve.
- Reinstall the KNOB MOUNT so that the arrow marking A points upwards.
- Reinstall RED LOCKING DEVICE.

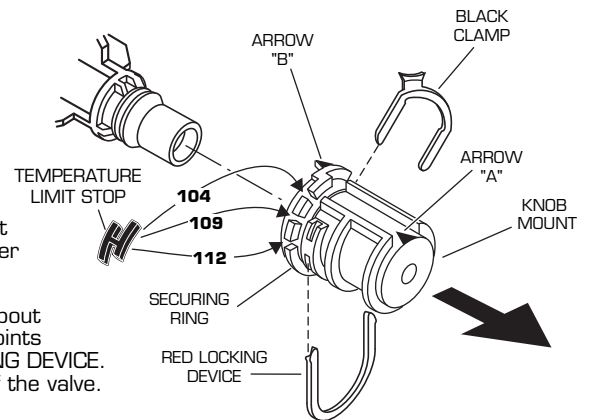

3 TRANSPOSED SUPPLY PIPING OR BACK TO BACK INSTALLATION

Should the hot and cold water supply pipes have been transposed making adjustment impossible, proceed as follows:

- Shut off water supply.
- Remove handle and rim
- Remove check stops and re-install them transposed.
- Important note: RED CHECK STOP is now on the right of the mixer body and the BLUE CHECK STOP is now on the left.
- Turn the water supply back on and perform the temperature adjustment in step 2.

