

Geneva Mailbox (Model 6700) Mounting and Use Instructions

Thank you for purchasing this premium locking mailbox. If you have any questions about how to mount or use this product, or if you need replacement parts, please call us directly at (800) 464-7491 or contact us at www.architecturalmailboxes.com.

Mounting your new mailbox

Your new mailbox comes completely assembled. To begin using your mailbox, it must be properly mounted. If you are using your mailbox at the curb or street, you are required to mount it in accordance with USPS requirements to facilitate carrier access, as described below.

Your mounting options are:

- 1) Use any one of our compatible posts, including the Basic 3" Round In-ground Post (7505), Decorative 3" Round In-ground Post (7507), Standard 4" Square In-Ground Post (5105), or Standard 4" Square Surface Mount Post (5106). Refer to the instructions that come with these posts for proper post installation.
- 2) Use a 4x4 wood post and our 4x4 Post Adapter (7530).

CUSTOMERS ARE REQUIRED TO CONTACT THE LOCAL POST OFFICE BEFORE INSTALLING THE MAILBOX TO ENSURE ITS CORRECT PLACEMENT AND HEIGHT AT THE STREET. GENERALLY, MAILBOXES ARE INSTALLED AT A HEIGHT OF 41-45 INCHES FROM THE ROAD SURFACE TO INSIDE FLOOR OF THE MAILBOX OR POINT OF MAIL ENTRY (LOCKED DESIGNS) AND ARE SET BACK 6-8 INCHES FROM THE FRONT FACE OF CURB OR ROAD EDGE TO THE MAILBOX DOOR.

1

For In-ground Posts

Dig a hole deep enough to allow the mailbox to sit at the specified height, as required by your local post office and generally as indicated at right.

For Surface Mount Posts

J-bolts (not included) placed into wet concrete:

Dig a hole deep and large enough to create a concrete pad to support the mailbox and post. The size will depend on the type of soil and location. Make sure the mailbox will sit at the specified height and distance from the curb, as required by your local post office and generally as indicated at right.

Anchors (not included) in preexisting dry concrete:

Make sure the anchor positions will allow for the specified set back and that the mailbox will sit at the correct height, as required by your local post office and generally as indicated at right.

2

For In-ground Posts:

Place the post in the hole and secure with concrete (at least 1 cubic foot recommended) completely around the post. NOTE - MAKE SURE THE HEIGHT AND LOCATION ARE CORRECT BEFORE THE CONCRETE IS SET.

For Surface Mount Posts:

J-bolts (not included) placed into wet concrete:

Pour the concrete pad around the j-bolts held in the correct pattern. Attach the post to the j-bolts using the hardware included with the j-bolts. NOTE - MAKE SURE THE PAD IS PROPERLY LOCATED AND AT THE RIGHT HEIGHT BEFORE THE J-BOLTS ARE SET IN THE CONCRETE.

Anchors (not included) in preexisting dry concrete:

Install the anchors into the concrete and attach the post base to the ground using the hardware supplied with the anchors.

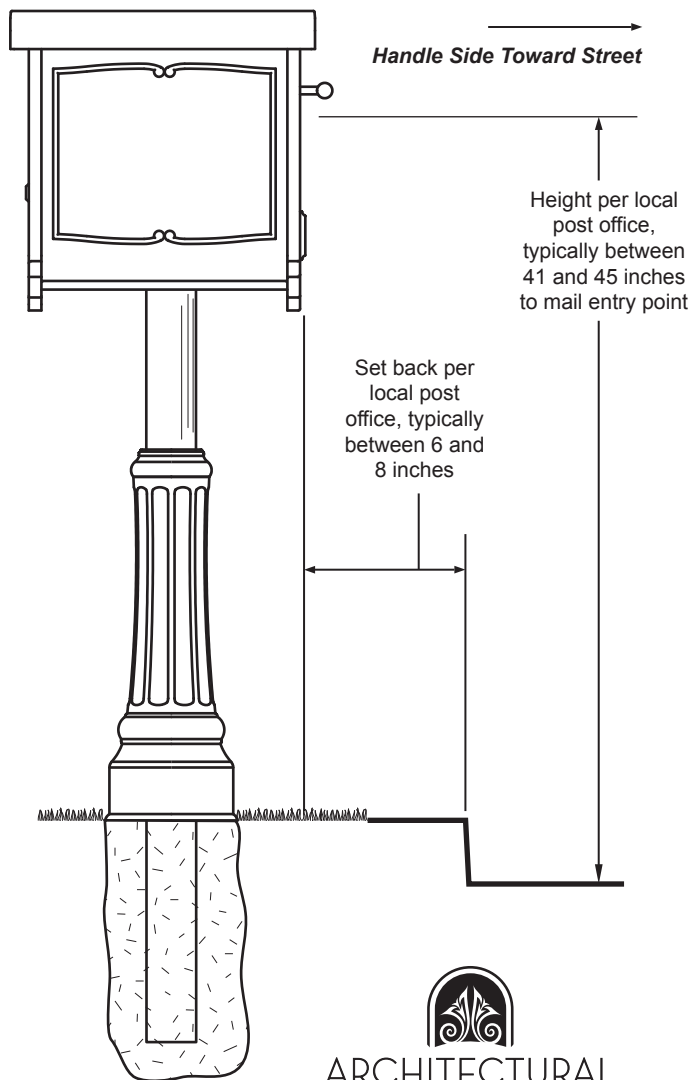

ARCHITECTURAL
MAILBOXES®

Geneva Mailbox (Model 6700) Mounting and Use Instructions

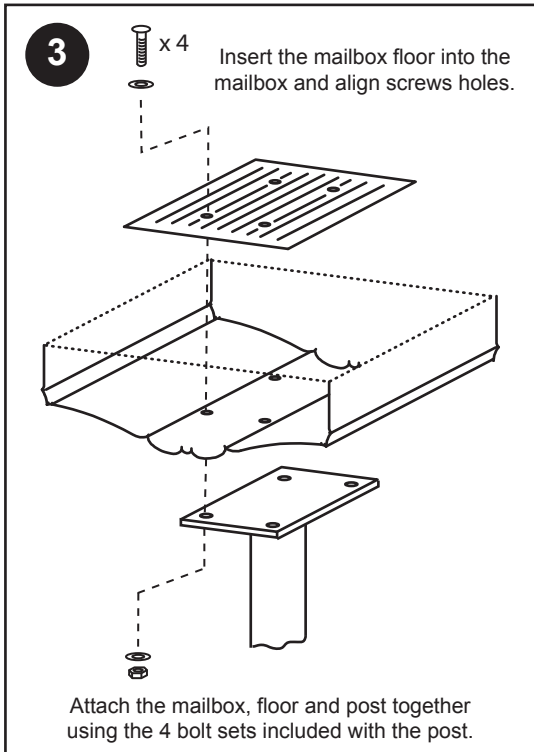

Using your new mailbox

OUTGOING MAIL
Place outgoing mail under the mail clip. Upon your carrier's next delivery, he or she will retrieve your outgoing mail.

INCOMING DELIVERIES
Your Geneva Mailbox is equipped with a hopper style door design for incoming mail. This design allows for the secure delivery of large volumes of mail and even small parcels.

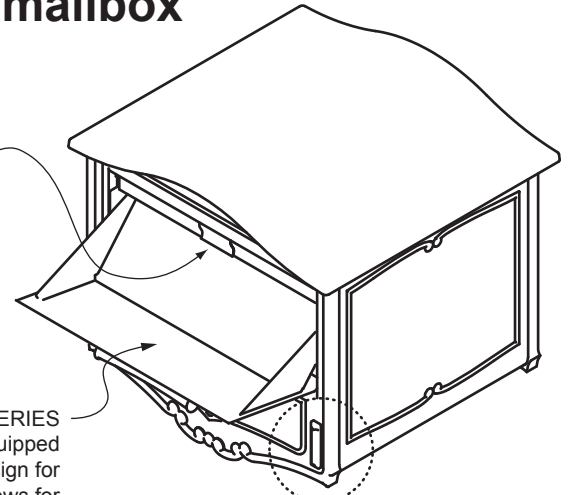

MAGNET CLOSURE
The incoming door magnet closure is located inside the mail storage compartment. It can be reached through the owner access door. Over time the closure may need to be adjusted. To adjust, loosen (don't remove) the screws that attach the closure to the flag assembly and raise up or down as needed. Once positioned correctly, retighten the screws.

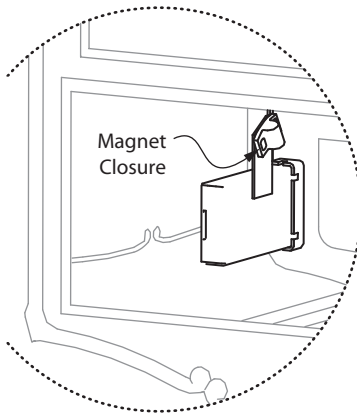

SIGNAL FLAG
When sending outgoing mail, release the signal flag by pushing the tip to the right. The spring loaded flag will extend automatically. To retract, simply push on the tip all the way in until it clicks into place.

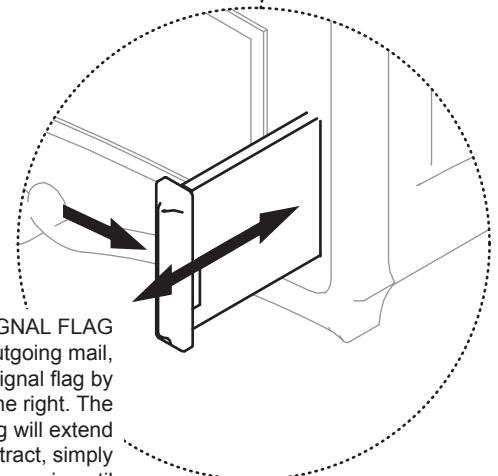

MAIL RETRIEVAL
To retrieve your mail, open the rear owner access door with the key.

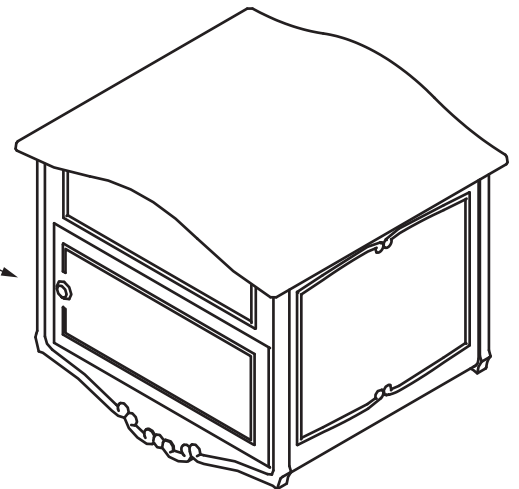

IT IS IMPORTANT TO NOTE THAT IT IS NOT THE RESPONSIBILITY OF MAIL CARRIERS TO OPEN MAILBOXES THAT ARE LOCKED, ACCEPT KEYS FOR THIS PURPOSE, OR LOCK MAILBOXES AFTER DELIVERAY OF THE MAIL.



ARCHITECTURAL
MAILBOXES®