

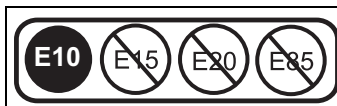

Owner/Operator Manual Manuel Du Propriétaire/Utilisateur

Model

939401 – Sno-Tek 20R
(SN 075000 +)

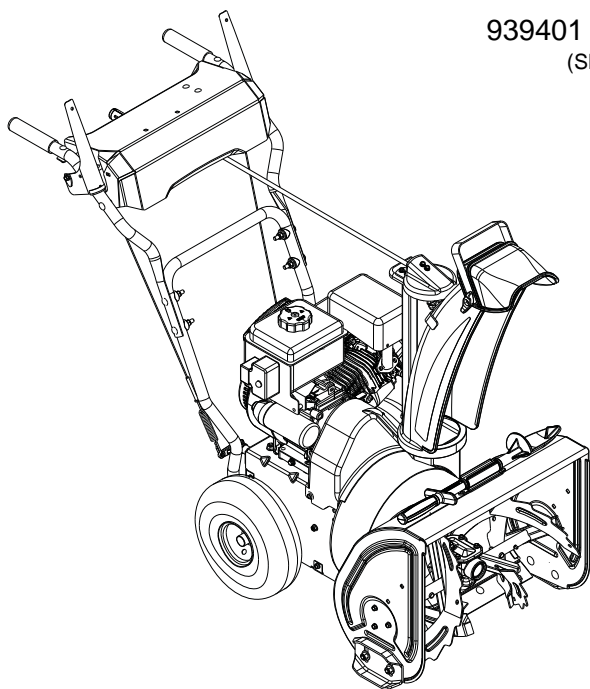

The use of any gasoline exceeding 10% ethanol (E10) or 10% MTBE will void the product warranty.

L'utilisation d'une essence contenant plus de 10% d'éthanol (E10) ou de 10% de MTBE annulent la garantie.



(EN) ENGLISH

(FR) FRANÇAIS

04334300D 11/13
Printed in USA

TABLE OF CONTENTS

SAFETY.....	4	STORAGE.....	23
ASSEMBLY.....	8	SERVICE PARTS	24
CONTROLS AND FEATURES	10	ACCESSORIES.....	24
OPERATION	11	TROUBLESHOOTING	25
MAINTENANCE	15	SPECIFICATIONS.....	26
SERVICE AND ADJUSTMENTS	18	WARRANTY	30

INTRODUCTION

THE MANUAL

Before operation of unit, carefully and completely read your manuals. If used improperly, this unit could be dangerous and cause personal injury or property damage. The contents will provide you with safety instructions for the safe use of your unit during normal operation and maintenance.

All reference to left, right, front, or rear are given from operator standing in operation position and facing the direction of forward travel.

ENGINE MANUAL

The engine on this unit is covered by a separate manual specific to the engine. This manual is included in the literature package that shipped with the unit. Refer to this manual for engine service recommendations. If the engine manual is not available, contact the engine manufacturer for a replacement manual.

MODEL AND SERIAL NUMBERS

When ordering replacement parts or making service inquiries, know the model and serial numbers of your unit and engine.

Numbers are located on the product registration form in the unit literature package. They are printed on a serial number label, located on the frame of your unit.

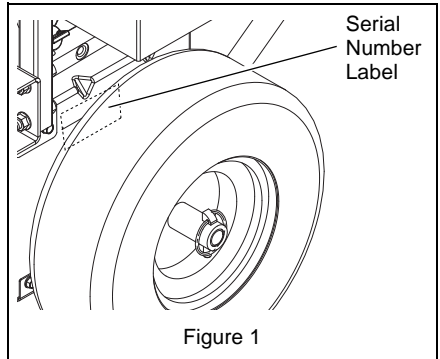

- Record unit model and serial numbers here.

- Record engine model and serial numbers here.

PRODUCT REGISTRATION

The Ariens dealer must register the product at the time of purchase. Registering the product will help the company process warranty claims or contact you with the latest service information. All claims meeting requirements during the limited warranty period will be honored, whether or not the product registration card is returned. Keep a proof of purchase if you do not register your unit.

Customer Note: If the dealer does not register your product, please fill out, sign, and return the product registration card to Ariens or go to www.ariens.com.

UNAUTHORIZED REPLACEMENT PARTS

Use only Ariens replacement parts. The replacement of any part on this vehicle with anything other than an Ariens authorized replacement part may adversely affect the performance, durability, or safety of this unit and may void the warranty. Ariens disclaims liability for any claims or damages, whether warranty, property damage, personal injury or death arising out of the use of unauthorized replacement parts. To locate your nearest Ariens dealer, go to www.ariens.com on the internet.

DISCLAIMER

Ariens reserves the right to discontinue, make changes to, and add improvements upon its products at any time without public notice or obligation. The descriptions and specifications contained in this manual were in effect at printing. Equipment described within this manual may be optional. Some illustrations may not be applicable to your unit.

DELIVERY

Customer Note: If you have purchased this product without complete assembly and instruction by your retailer, it is your responsibility to:

1. Read and understand all assembly instructions in this manual. If you do not understand or have difficulty following the instructions, contact your nearest Ariens dealer for assistance. Make sure all assembly has been properly completed.

NOTE: To locate your nearest Ariens dealer, go to www.ariens.com on the internet.



WARNING: Improper assembly or adjustments can cause serious injury.

2. Understand all safety precautions provided in the manuals.
3. Review control functions and operation of the unit. Do not operate the Sno-Tek™ unless all controls function as described in this manual.
4. Review recommended lubrication, maintenance and adjustments.
5. Review limited warranty policy.
6. Fill out a product registration card and return the card to the Ariens Company or go to www.ariens.com.

SAFETY



WARNING: To avoid injury to hands and feet, always disengage clutches, shut off engine, and wait for all movement to stop before unclogging or working on snow thrower.

Hand contact with the rotating impeller is the most common cause of injury associated with snow throwers. Never use your hand to clean out the discharge chute. Keep hands and feet away from auger and impeller.

SAFETY ALERTS



Look for these symbols to point out important safety precautions. They mean:

Attention!



Personal Safety Is Involved!

Become Alert!

Obey The Message!

The safety alert symbols above and signal words below are used on decals and in this manual. Read and understand all safety messages.



DANGER: IMMINENTLY HAZARDOUS SITUATION! If not avoided, WILL RESULT in death or serious injury.



WARNING: POTENTIALLY HAZARDOUS SITUATION! If not avoided, COULD RESULT in death or serious injury.



CAUTION: POTENTIALLY HAZARDOUS SITUATION! If not avoided, MAY RESULT in minor or moderate injury. It may also be used to alert against unsafe practices.

NOTATIONS

NOTE: General reference information for proper operation and maintenance practices.

IMPORTANT: Specific procedures or information required to prevent damage to unit or attachment.

SAFETY DECALS AND LOCATIONS

ALWAYS replace missing or damaged safety decals. Refer to Figure 2 below for safety decal locations.

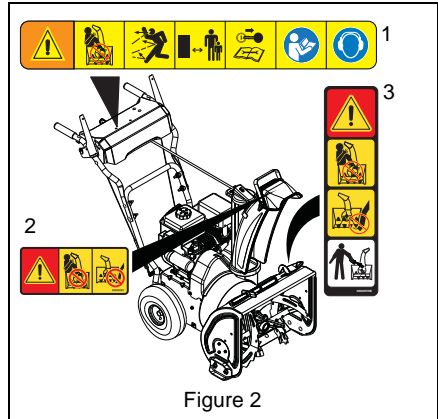

Figure 2

1. DANGER!



Danger!



ONLY use clean-out tool to clear blockages. NEVER use your hands.



Never direct discharge towards persons or property that may be injured or damaged by thrown objects.



Keep people away from unit while operating. Keep children out of work area and under watchful care of a responsible adult.



Stop engine, remove key, read manual before making any repairs or adjustments.



Read Owner/Operator Manual.



Wear appropriate hearing protection.

2. DANGER!



Danger!



ROTATING PARTS. Keep clear of auger while engine is running.



- Read Operator's Manual.
- Allow operation only by properly trained adult, never children.
- Stop engine and remove ignition key prior to leaving the operator's position for any reason.
- Keep all controls, guards and safety devices properly serviced and functional.
- Never direct discharge towards persons or property that may be injured or damaged by thrown objects.

3. DANGER!



Danger!



ROTATING PARTS! ONLY use clean-out tool to clear blockages. **NEVER** use your hands. **High speed impeller rotates below discharge opening. Wait for all moving parts to stop before removing clogs or servicing.**



SAFETY RULES

Read, understand, and follow all safety practices in owner/operator manual before beginning assembly or operating. Failure to follow instructions could result in personal injury and/or damage to unit.

ALWAYS remove key and/or wire from spark plug before assembly, maintenance or service. Unintentional engine start up can cause death or serious injury.

Complete a walk around inspection of unit and work area to understand:

- Work area
- Your unit
- All safety decals

ALWAYS check overhead and side clearances carefully before operation. **ALWAYS** be aware of traffic when operating along streets or curbs.

Keep children and people away. Keep children out of work area and under watchful care of a responsible adult.

NEVER allow children to operate or play on or near unit. Be alert and shut off unit if children enter area.

DO NOT allow adults to operate unit without proper training. Only trained adults may operate unit. Training includes actual operation.

Keep area of operation clear of all toys, pets, and debris. Thrown objects can cause injury.

Check for weak spots on docks, ramps or floors. Avoid uneven work areas and rough terrain. Stay alert for hidden hazards.

DO NOT operate near drop-offs, ditches, or embankments. Unit can suddenly turn over if a wheel is over the edge of a cliff or ditch, or if an edge caves in.

Falling snow, fog, etc. can reduce vision and cause an accident. Operate unit only when there is good visibility and light.

NEVER operate unit after or during the use of medication, drugs or alcohol. Safe operation requires your complete and unimpaired attention at all times.

NEVER allow anyone to operate this unit when their alertness or coordination is impaired.

DO NOT operate unit without wearing adequate winter outer garments. Wear adequate safety gear, including safety glasses with side shields, and protective gloves. Wear proper footwear to improve footing on slippery surfaces.

DO NOT wear loose clothing or jewelry and tie back hair that may get caught in rotating parts.

Protect eyes, face and head from objects that may be thrown from unit. Wear appropriate hearing protection.

Avoid sharp edges. Sharp edges can cut. Moving parts can cut off fingers or a hand.

ALWAYS keep hands and feet away from all rotating parts during operation. Rotating parts can cut off body parts.

NEVER place your hands or any part of your body or clothing inside or near any moving part while unit is running.

ALWAYS keep hands away from all pinch points.

DO NOT touch unit parts which might be hot from operation. Allow parts to cool before attempting to maintain, adjust or service.

Never direct discharge towards persons or property that may be injured or damaged by thrown objects. Use extreme caution on gravel surfaces. Stay alert for hidden hazards or traffic. Adjust skid shoes so scraper blade does not contact gravel.

DO NOT throw snow any higher than necessary.

Deflected materials can cause injury and property damage.

Always stand clear of the discharge area when operating this unit.

Fumes from engine exhaust can cause injury or death. DO NOT run engine in an enclosed area. Always provide good ventilation.

ALWAYS disengage attachment, stop unit and engine, remove key and allow moving parts to stop before leaving operator's position.

ROTATING IMPELLER CAN CAUSE SERIOUS INJURY. NEVER ATTEMPT TO UNCLOG OR CLEAN UNIT WHILE ENGINE IS RUNNING.

Read, understand, and follow all instructions in the manual and on the machine before starting.

Understand:

- How to operate all controls.
- The functions of all controls.
- How to STOP in an emergency.

Before starting engine, disengage control(s).

ALWAYS allow unit and engine to adjust to outdoor temperatures before clearing snow.

Always be sure of your footing, especially when operating in reverse or leaving the operator's position. Walk, never run during operation.

DO NOT overload the machine capacity by attempting to operate or to clear snow at too fast a rate.

Slow down and turn corners slowly.

Do not operate in reverse unless absolutely necessary. ALWAYS back up slowly. Always look down and behind before and while backing.

Disengage attachment drive when traveling from one work area to another.

Abnormal vibrations are a warning of trouble.

Striking a foreign object can damage unit.

Immediately stop unit and engine. Remove key and wait for all moving parts to stop.

Remove wire from spark plug. Inspect unit and make any necessary repairs before restart.

Before cleaning, removing clogs or making any inspections, repairs, etc.: disengage clutch(es), stop unit and engine, remove key, allow moving parts to stop. Allow hot parts to cool.

Run unit a few minutes after clearing snow to prevent freeze-up of attachment.

Disengage attachment when not in use.

Disengage all clutches before starting engine.

Adjust skid shoes to clear gravel or crushed rock surfaces safely.

Never leave a running unit unattended.
ALWAYS shut off engine before leaving unit.
ALWAYS remove key to prevent unauthorized use.

Never carry passengers.

Check clutch and brake operation frequently.
Adjust and service as required. All motion of drive wheels and auger/impeller must stop quickly when control levers are released.

DO NOT operate on steep slopes. DO NOT clear snow across the face of slopes. Keep all movement on slopes slow and gradual. DO NOT make sudden changes in speed or direction. Use a slow speed to avoid stops or shifts on slopes. Avoid starting or stopping on a slope.

DO NOT park unit on a slope unless absolutely necessary. When parking on a slope always block the wheels.

ALWAYS shut off engine, remove key, and close fuel shut-off valve or drain fuel when transporting unit on a truck or trailer.

Use extra care when loading or unloading unit onto trailer or truck.

Secure unit chassis to transport vehicle.
NEVER secure from rods or linkages that could be damaged.

DO NOT transport machine while engine is running.

Keep unit free of ice or other debris. Clean up oil or fuel spills.

This product is equipped with an internal combustion type engine. DO NOT use unit on or near any unimproved, forest-covered or brush covered land unless exhaust system is equipped with a spark arrester meeting applicable local, state or federal laws. A spark arrester, if it is used, must be maintained in effective working order by operator.

Fuel is highly flammable and its vapors are explosive. Handle with care. Use only an approved gasoline container with an appropriately sized dispensing spout.
NO smoking, NO sparks, NO flames.
ALWAYS allow engine to cool before servicing.

NEVER fill fuel tank when engine is running or hot from operation.

NEVER fill or drain fuel tank indoors.

Replace fuel cap securely and clean up spilled fuel.

Never fill containers inside a vehicle or on a truck or trailer bed with a plastic liner. Always place containers on the ground away from your vehicle before filling.

When practical, remove gas-powered equipment from the truck or trailer and refuel it on the ground. If this is not possible, then refuel such equipment on a trailer with a portable container, rather than from a gasoline dispenser nozzle.

Keep the nozzle in contact with the rim of the fuel tank or container opening at all times until fueling is complete. Do not use a nozzle lock-open device.

If fuel is spilled on clothing, change clothing immediately.

Before tipping unit up onto housing, remove fuel so no spills will occur. Ensure unit is secure and will not tip over during maintenance.

ALWAYS keep protective structures, guards, and panels in good repair, in place and securely fastened. NEVER modify or remove safety devices.

DO NOT change engine governor settings or over-speed engine.

Fumes from engine exhaust can cause injury or death. DO NOT run engine in an enclosed area. Always provide good ventilation.

ALWAYS maintain unit in safe operating condition. Damaged or worn out muffler can cause fire or explosion.

Keep all hardware properly tightened. Check shear bolts frequently.

Maintain or replace safety and instruction labels, as necessary.

NEVER store unit with fuel in fuel tank, inside a building where any ignition sources are present such as hot water heaters, space heaters, or clothes dryers. Allow the engine to cool before storing in any enclosure.

Shut off fuel and allow engine to cool completely before storing in closed area or covering unit.

For extended storage, clean unit thoroughly. See engine manual for proper storage.

Use only attachments or accessories designed for your unit.

Check components frequently. If worn or damaged, replace with manufacturer's recommended parts.

ASSEMBLY



WARNING: AVOID INJURY. Read and understand the entire *Safety* section before proceeding.



WARNING: Dropping or tipping over boxed unit could result in personal injury or damage to unit.

PACKAGE CONTENTS

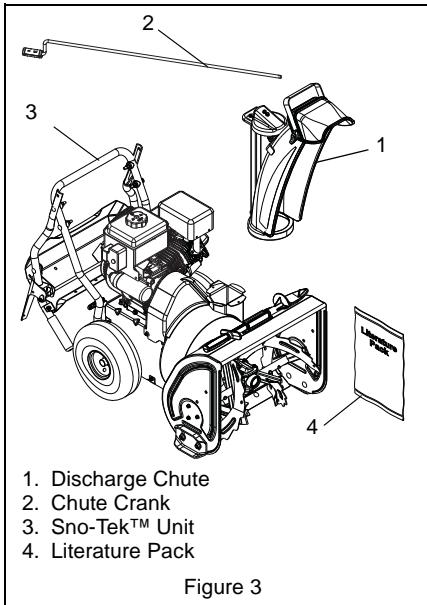

1. Discharge Chute
2. Chute Crank
3. Sno-Tek™ Unit
4. Literature Pack

Figure 3

ASSEMBLY

Tools Required

- Pliers
- Open-end wrenches: 3/8, 7/16, 1/2, 9/16 in. and/or adjustable wrench
- Tire gauge

Unfold Handlebar

(Figure 4)

1. Remove the lower and loosen the upper hardware on the handlebar assembly.
2. Rotate the handlebars into operating position.

NOTE: Be careful not to damage the cable spring hooks when rotating handlebars upward.

3. Install and tighten the hardware on the handlebar assembly.

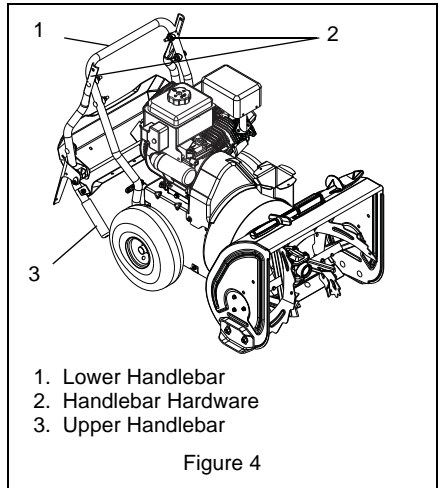

1. Lower Handlebar
2. Handlebar Hardware
3. Upper Handlebar

Figure 4

Install Discharge Chute

(Figure 5)

1. Remove mounting hardware from the auger housing.
2. Install discharge chute over opening in the auger housing and secure pedestal to auger housing with hardware removed in step 1.

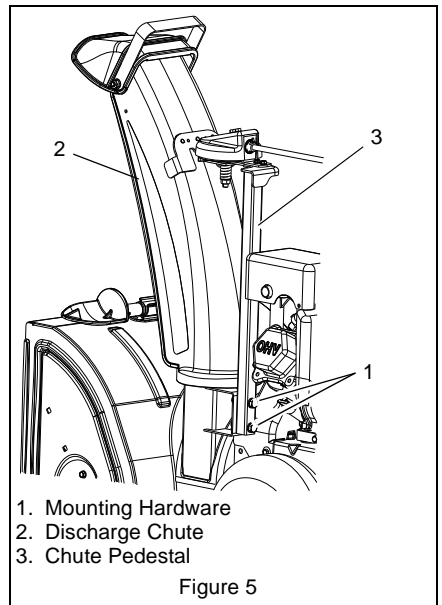

1. Mounting Hardware
2. Discharge Chute
3. Chute Pedestal

Figure 5

Install Discharge Chute Crank

(Figure 6)

1. Slide chute crank through crank support bracket.

NOTE: Be careful not to damage the nylon bushing when sliding crank through bracket.

2. Connect the chute crank to the pinion gear on chute with spring clip pin.

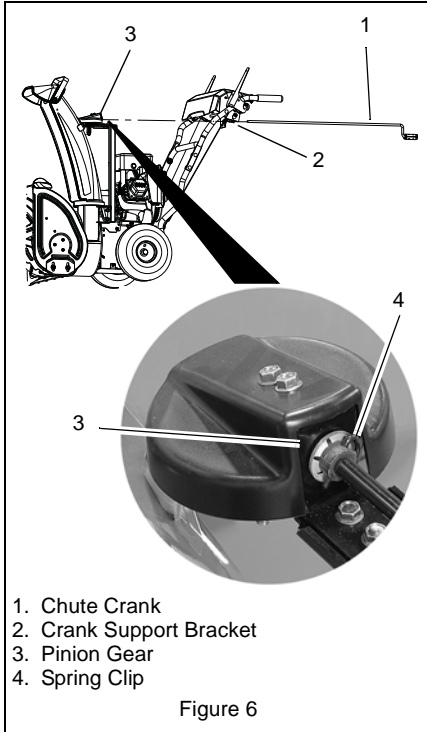

Check Function of Dual Handle Interlock

Without the engine running, press down (engage) both clutch levers. Release attachment clutch lever. Attachment clutch should remain engaged until traction drive clutch lever is released, then both clutches *must* disengage. If they do not, contact your dealer for repairs.

Check Tire Pressure

Check tire pressure and adjust to the pressure listed on tire sidewall.



CAUTION: Avoid injury! Explosive separation of tire and rim parts is possible when they are serviced incorrectly:

- Do not attempt to mount a tire without the proper equipment and experience to perform the job.
- Do not inflate the tires above the recommended pressure.
- Do not weld or heat a wheel and tire assembly. Heat can cause an increase in air pressure resulting in an explosion. Welding can structurally weaken or deform the wheel.
- Do not stand in front or over the tire assembly when inflating. Use a clip-on chuck and extension hose long enough to allow you to stand to one side.

Check Auger Gearcase Oil

Check oil level in auger gearcase (see *Check Auger Gearcase* on page 16).

Check Engine Crankcase Oil

IMPORTANT: The engine is shipped with 5W-30 oil in crankcase. Refer to engine manual for detailed instructions.

Fill Engine Fuel Tank

See *Filling Fuel Tank* on page 12.

Check Function of all Controls

Ensure unit runs and performs properly. Refer to *Operation*.

Run-in Attachment Belt

1. Start unit in a well-ventilated area according to *Starting and Shut Off* on page 14.
2. Engage attachment clutch lever and run attachment for about 15 minutes.
3. Stop unit, wait for all moving parts to stop, and remove spark plug wire.
4. Adjust belt fingers, if necessary. See *Check Belt Finger Clearance* on page 21.
5. Adjust clutch according to *Attachment Clutch/Brake Adjustment* on page 19.

CONTROLS AND FEATURES

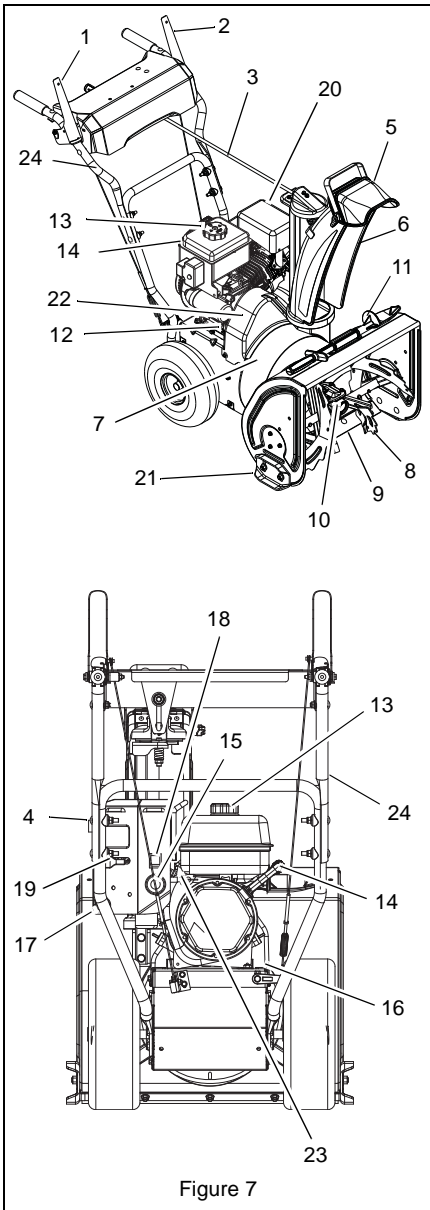

1. Attachment Clutch Lever
2. Traction Drive Clutch Lever
3. Chute Crank
4. Muffler Guard
5. Discharge Chute Deflector
6. Discharge Chute
7. Impeller
8. Auger
9. Scraper Blade
10. Auger Gearcase
11. Clean-out Tool
12. Oil Fill and Dipstick
13. Gas Tank and Cap
14. Recoil Starter Handle
15. Primer Bulb
16. Oil Drain Plug
17. Ignition Switch (push-pull)
18. Engine Shut-off Switch
19. Choke
20. Spark Plug and Wire
21. Skid Shoes
22. Belt Cover
23. Fuel Shut-Off Valve
24. Handlebar

OPERATION



WARNING: AVOID INJURY. Read and understand the entire *Safety* section before proceeding.



WARNING: To avoid injury to hands and feet, always disengage clutches, shut off engine, and wait for all movement to stop before unclogging or working on snow thrower.

Keep hands and feet away from auger and impeller.

CONTROLS AND FEATURES

See *CONTROLS AND FEATURES* on page 10 for all control and feature locations.

Dual Handle Interlock

When attachment clutch and then traction drive clutch are engaged, the attachment clutch will remain engaged (lever down) if released. To stop attachment, release traction drive clutch and both clutches will disengage.

Traction Drive Clutch - Left Hand Lever

IMPORTANT: Do not "feather" the traction drive clutch to control speed or run the unit with the traction drive clutch partially engaged. Continued use with the traction drive clutch partially engaged will damage the transmission.

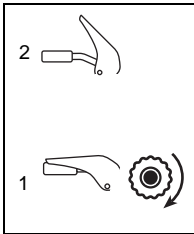

Squeeze the traction drive clutch lever against the handlebar (1) to engage wheel drive for propelling unit. Forward speed will vary according to snow depth and moisture content.

Release lever (2) to stop movement.

NOTE: When traveling to or from the area to be cleared, press down on the handlebars enough to raise the front of the unit slightly off the surface, disengage traction drive clutch and push unit to new work area.

Attachment Clutch - Right Hand Lever

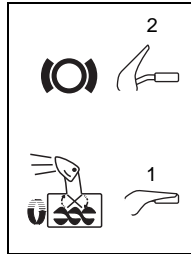

Squeeze attachment clutch lever against handlebar (1) to engage attachment. Release both clutch levers (2) to disengage power and apply brake to attachment.

IMPORTANT: If the belt squeals when the attachment clutch lever

is engaged, the impeller may be frozen in the auger housing. Immediately release the attachment clutch lever and move the unit into a heated area to thaw.

NOTE: If belt squeals when impeller turns freely, see *Attachment Clutch/Brake Adjustment* on page 19.

Ignition Switch (Push/Pull Safety Key)

Key Switch has two positions:

1. "Stop" - pulled out
2. "Run" - pushed in

NOTE: DO NOT twist key after it is inserted.

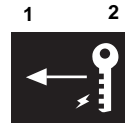

Engine shut-off Switch

1. Set the engine shut-off switch to the "Run" position to start and operate the engine.
2. Set the engine shut-off switch to the "Stop" position to shut off a running engine.

Primer Bulb



Pushing the primer bulb in adds fuel for easier engine start. Refer to *Starting and Shut Off* on page 14.

Fuel Shut-Off Valve

IMPORTANT: The fuel shut-off valve **MUST** be in the closed position prior to transporting the unit.

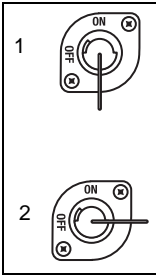

The fuel shut-off valve has two positions:

Open Position (1): Use this position to run the unit.

Closed Position (2): Use this position to service, transport, or store the unit.

Choke Control



1. Choke Closed position: chokes off air to engine for easier start.

2. Choke Open position: allows for normal operation.

IMPORTANT: Gradually open choke after engine starts.

Recoil Starter Handle

When pulled, handle will turn engine over. See *Starting and Shut Off* on page 14.

IMPORTANT: DO NOT let handle snap back against starter.

Snow Clean-Out Tool

(Figure 8)



WARNING: Hand contact with the rotating impeller is the most common cause of injury associated with snow throwers. Never use your hand to clean out the discharge chute.

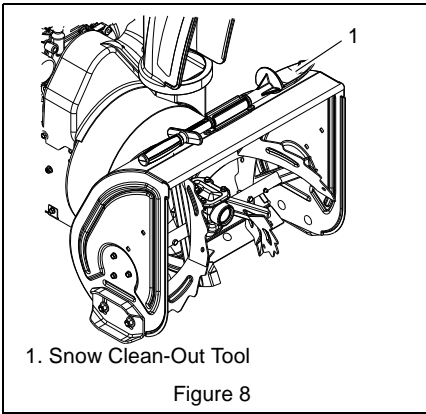

1. Snow Clean-Out Tool

Figure 8

To clear the discharge chute:

1. Shut off the engine.
2. Wait 10 seconds and make sure impeller blades have stopped rotating.
3. Remove the snow clean-out tool (1) from the auger housing and use it to remove the clog from the discharge chute.
4. Replace the snow clean-out tool on the auger housing.

Discharge Chute Deflector

ALWAYS position discharge chute deflector at a safe angle before starting engine.

DO NOT throw snow any higher than necessary.

Push deflector handle forward or down to throw snow lower. Pull deflector handle up or to the rear to throw snow higher.

IMPORTANT: If chute deflector does not stay in set position, adjust as directed in *Discharge Chute Deflector* on page 18, or repair before operation.

Discharge Chute

Discharge chute rotates 205°.

ALWAYS position discharge chute in safe direction and angle, away from operator and bystanders, before starting engine.

Chute Crank

IMPORTANT: If chute does not stay in set position, adjust as directed in *Discharge Chute* on page 19, or repair before operation. Rotate the chute with discharge chute crank.

IMPORTANT: DO NOT force frozen chute controls. If still frozen, take to warm place until controls are free.

Scraper Blade

The scraper blade allows better contact with the surface being cleared. It also prevents damage to the housing from normal usage.

IMPORTANT: DO NOT allow scraper blade to wear too far or auger/impeller housing will become damaged.

Skid Shoes

The skid shoes control the distance between the scraper blade and the ground. Adjust skid shoes equally to keep blade level with the ground. Refer to *Pre-Start* on page 13 for recommended settings.

FILLING FUEL TANK



WARNING: AVOID INJURY. Read and understand the entire *Safety* section before proceeding.

GASOLINE

Fuel Recommendations

Use unleaded gasoline with a pump octane rating of 86 or higher. These engines operate best on unleaded gasoline.



CAUTION: Do NOT use stale or contaminated gasoline or an oil/gasoline mixture. Avoid getting dirt or water in the fuel tank. Use only proper fuel containers that are properly marked.



CAUTION: DO NOT use E85 blended fuels. This engine is not E20/E30/E85 compatible.

- Gasoline with up to 10% ethanol (gasohol) or up to 10% MTBE (methyl tertiary butyl ether) is acceptable.
- Use of any gasoline other than those approved above will void the engine warranty. If the pumps are not marked for the content of alcohol or ethers, check ethanol and MTBE levels with the fuel supplier.

Adding a Fuel Stabilizer to Extend Fuel Storage Life

NOTE: Fuel stabilizer is recommended for long term storage.

1. Turn the fuel valve off while engine is running and allow the engine to run until it stops. Turn engine OFF when it begins surging to avoid engine damage.
2. Add fuel stabilizer, following the manufacturer's instructions.
3. Turn fuel valve on after adding fuel stabilizer.
4. Re-start engine.
5. Run the engine outdoors for 1 minute to be sure that treated gasoline has replaced the untreated gasoline in the carburetor.
6. Slow the engine to an idle speed.
7. Repeat step 1 above.

To add fuel to fuel tank:

1. ALWAYS place unit in open or well-ventilated area.
2. Stop engine and allow to cool.
3. Clean fuel cap and surrounding area to prevent dirt from entering fuel tank.
4. Remove cap.

IMPORTANT: Refer to Engine Manual for proper fuel type and tank capacity

5. Replace fuel cap and tighten.
6. ALWAYS clean up any spilled fuel.

PRE-START

1. Frozen Impeller

IMPORTANT: Before starting engine, check impeller to be sure it is not frozen.

To check impeller:

1. With ignition key switch in "Stop" position, squeeze attachment clutch lever to engaged position.
2. Pull recoil starter handle.
3. If Impeller is frozen, (cannot pull starter handle) move unit to a heated area and thaw to prevent possible damage.

2. Check Function of Clutches

If clutches do not engage or disengage properly, adjust or repair before operation (see *Check Clutch Operation* on page 15).

3. Check Dual Handle Interlock

Without the engine running, press down (engage) both clutch levers. Release attachment clutch lever. Attachment clutch should remain engaged until traction drive clutch lever is released, then both clutches *must* disengage.

4. Check Skid Shoes

Check and adjust skid shoes (see *Skid Shoes* on page 18). Allow 1/8 in. (3 mm) between scraper blade and hard, smooth surface(s). Allow 1-1/4 in. (30 mm) between scraper blade and uneven or gravel surfaces.

5. Check Engine Fuel & Crankcase Oil



WARNING: AVOID INJURY. Read and understand the entire *Safety* section before proceeding.

Check and add fuel if required. Check that the engine crankcase oil is full using dipstick. Refer to engine manual for detailed instructions.

TO STOP IN AN EMERGENCY

Immediately release both control levers to stop unit in an emergency. Stop engine, remove key and wait for all rotating parts to stop before leaving operator's position.

STARTING AND SHUT OFF



WARNING: FAILURE TO FOLLOW INSTRUCTIONS could result in personal injury and/or damage to unit. DO NOT attempt to start your unit at this time. Read entire owner/operator manual and the engine manual first.

IMPORTANT: Allow unit and engine to adjust to the outdoor temperature before clearing snow. Before shut-off, run the attachment a few minutes to prevent impeller freeze-up.

NOTE: Try out each control without the engine running to see how it works and what it does.

Manual Start

1. Turn discharge chute straight ahead.
2. Make sure that the traction clutch and attachment drive clutch levers are fully disengaged.
3. Push primer bulb 2 or 3 times for cold engine.

NOTE: When temperature is below -15° F (-26° C) additional priming may be needed.

4. If engine is cold, apply choke. See engine manual for detailed instructions.

NOTE: A warm engine requires less choking than a cold engine.

5. Insert key into ignition switch and push into RUN position. DO NOT twist key after it is inserted.
6. Turn on engine shut-off switch (Run).
7. Grasp starter handle and pull rope out slowly until it pulls harder. Let rope rewind slowly.
8. Pull rope with a rapid continuous full arm stroke. Let rope rewind slowly.

IMPORTANT: DO NOT let starter handle snap against starter.

9. Repeat steps 7 and 8 until engine starts. (If engine does not start, refer to **TROUBLESHOOTING** on page 25.)
10. Adjust choke as needed.

Shut Off

1. Release traction drive clutch lever and allow unit to come to a complete stop.
2. Run impeller a few minutes after use to prevent freeze-up of impeller.
3. Release attachment clutch lever and wait for all moving parts to come to a complete stop.

4. Turn off the engine shut-off switch (Stop).

5. Remove key.

SNOW REMOVAL

IMPORTANT: Allow unit and engine to adjust to the outdoor temperature before clearing snow.

IMPORTANT: Do not "feather" the traction drive clutch to control speed or run the unit with the traction drive clutch partially engaged. Continued use with the traction drive clutch partially engaged will damage the transmission.

NOTE: Attachment clutch should be engaged before wheel drive clutch when throwing snow.

1. Engage attachment clutch - right hand lever.
2. Engage traction drive clutch - left hand lever.

IMPORTANT: DO NOT overload unit capacity by attempting to clear snow at too fast a rate. Use slow speed to clear deep or hard packed snow.

Tips for Operation

Snow is best removed as soon as possible after snow fall.

To clear an area, run unit in an overlapping series of paths. For large areas, start in the middle and throw snow to each side, so snow is not cleared more than once.

ALWAYS direct snow away from area to be cleared and with direction of the wind.

TRAVELING

To travel from one work area to another:

1. Press down on handlebars enough to raise front of unit slightly off surface.
2. Disengage traction drive clutch and push unit to new work area.

TRANSPORT

ALWAYS shut off engine, remove key, and close fuel shut-off valve when transporting unit on a truck or trailer.

Use extra care when loading or unloading unit onto trailer or truck.

Secure unit chassis to transport vehicle. NEVER secure from rods or linkages that could be damaged.

DO NOT transport machine while engine is running.

MAINTENANCE

Ariens dealers will provide any service or adjustments which may be required to keep your unit operating at peak efficiency. Should engine service be required, contact an Ariens dealer or an authorized engine manufacturer's service center.



WARNING: AVOID INJURY. Read and understand the entire *Safety* section before proceeding.

SERVICE POSITION

(Figure 9)



WARNING: Before tipping unit up onto housing, remove fuel so no spills will occur. Ensure unit is secure and will not tip over during maintenance.

Place unit on a flat level surface. Tip unit forward onto front of auger housing for service. Ensure unit is secure and will not tip over. Strap and clamp onto bench if needed.

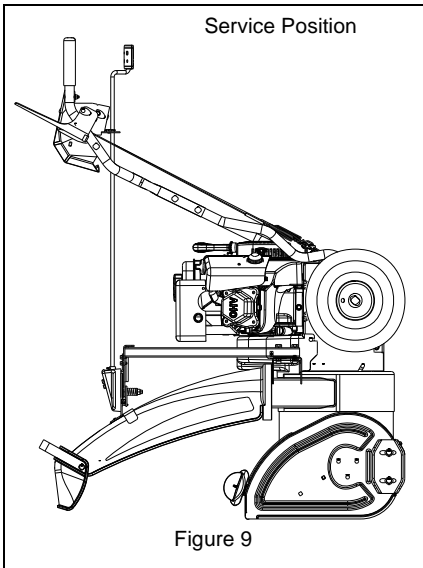

MAINTENANCE SCHEDULE

The chart below shows the recommended maintenance schedule that should be performed on a regular basis. More frequent service may be required.

MAINTENANCE SCHEDULE

Service Performed	Each Use	Every 5 hrs.	Every 25 hrs.	Yearly
Check Dual Handle Interlock	•			
Check Fasteners	•			
Check Clutch Operation	•			
Check Clutch Cable Adjustments		*	•	
Clean Engine	•			
Check Engine Oil		•		
Change Engine Oil**				
Check Tire Pressure			•	
Check Auger Gearcase			•	•
General Lubrication			•	•

* After first 5 hours of operation.

** Refer to Engine Manual for detailed instructions.

CHECK DUAL HANDLE INTERLOCK

Without the engine running, press down (engage) both clutch levers. Release attachment clutch lever. Attachment clutch should remain engaged until traction drive clutch lever is released, then both clutches *must* disengage.

CHECK FASTENERS

Make sure all hardware is tightened properly.

CHECK CLUTCH OPERATION

Auger/impeller must stop within 5 seconds when attachment clutch/impeller brake lever is released.

Wheels must stop quickly when traction drive clutch lever is released.

If clutches do not engage or disengage properly, adjust or repair before operation (see *Attachment Clutch/Brake Adjustment* on page 19 or *Traction Drive Clutch Adjustment* on page 21).

CHECK CLUTCH CABLE ADJUSTMENT

Make sure the attachment clutch and traction drive clutch are adjusted to the range specified in *Attachment Clutch/Brake Adjustment* on page 19 or *Traction Drive Clutch Adjustment* on page 21.

CLEAN ENGINE

Refer to engine manual for detailed instructions.

CHECK ENGINE OIL

The engine crankcase oil should be checked every 5 hours of operation. Oil level **MUST** be maintained in safe operating range on dipstick at all times or engine damage will result (See engine manual).

Park unit on a level surface. Refer to engine manual for detailed instructions.

CHANGE ENGINE OIL

Refer to engine manual for detailed instructions.

Run engine just prior to changing oil. Warm oil will flow more freely and carry away more contamination.

CHECK TIRE PRESSURE

Keep tires at pressure listed on the tire sidewall. See *Check Tire Pressure* on page 9.

CHECK AUGER GEARCASE

(Figure 10)

IMPORTANT: Proper oil level must be maintained.

Gear cases are filled to the correct level at the factory. Unless there is evidence of leakage, no additional lubricant should be required. Check oil level each season or every 25 hours of operation.

IMPORTANT: Be sure unit is resting on a level surface before checking lubricant levels.

To ensure adequate lubricant level:

1. Remove oil fill plug and seal washer (Figure 10). Lubricant must be 1.63 in. – 1.88 in. (4.14 cm – 4.78 cm) from the flat surface of the gear case cover.

IMPORTANT: DO NOT remove the gear case cover.

2. Check oil level with suitable dipstick device. Add lubricant if required.

NOTE: Inspect seal washer for wear or rubber deterioration and replace as needed.

IMPORTANT: Use only Ariens L3 synthetic severe duty gear lube (Part Number 00068800). Use of other lubricants will void unit warranty.

3. Reinstall oil fill plug and seal washer to 80 lbf-in. (9 N•m).

IMPORTANT: DO NOT OVER-TORQUE! Note that measurements are in pound force inches (lbf-in) and NOT pound force foot (lbf-ft).

IMPORTANT: Be sure to install seal washer with rubber side down (Figure 10).

IMPORTANT: Improper torquing, omission of seal washer, or incorrect installation of seal washer will void unit warranty.

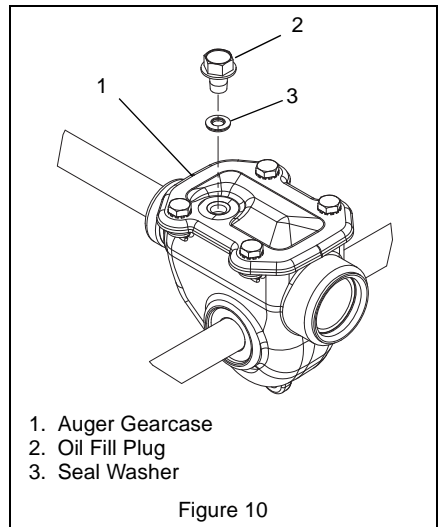

GENERAL LUBRICATION

IMPORTANT: Wipe each fitting clean before and after lubrication.

IMPORTANT: DO NOT allow grease or oil to get on the belts.

NOTE: Apply Ariens Hi-Temp Grease or equivalent to the lubrication fittings. See *SERVICE PARTS* on page 24.

Unit should be lubricated at beginning of season or every 25 operating hours.

Auger Shaft

(Figure 11)

To grease auger shaft, remove shear bolt nuts and shear bolts per instructions in *Shear Bolts* on page 18. Apply grease at the grease zerks and then turn the auger assemblies on the auger shaft. Replace shear bolts.

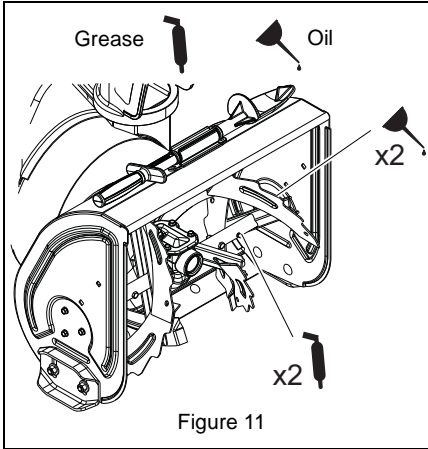

Axle Shaft

(Figure 12)

Grease the axle gear and oil the axle bushings.

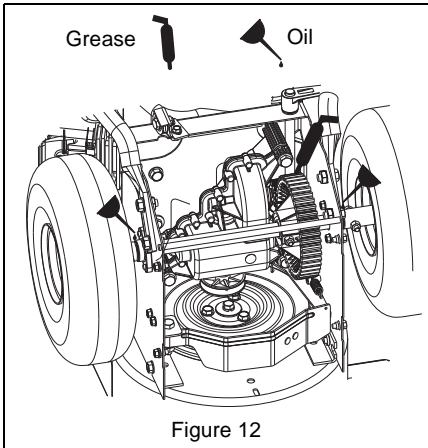

SERVICE AND ADJUSTMENTS



WARNING: AVOID INJURY. Read and understand the entire *Safety* section before proceeding.

SCRAPER BLADE

IMPORTANT: Damage to auger/impeller housing will result if blade wears down too far.

Scraper blade is adjustable to compensate for wear.

To adjust scraper blade:

1. Tip unit back onto handlebar, support housing and loosen nuts retaining blade.
2. Adjust skid shoes to fully raised position (housing closest to ground).
3. Reposition scraper blade flush with skid shoes and tighten lock nuts.

SKID SHOES

(Figure 13)

Skid shoes should be adjusted as conditions require.

1. Position unit on a hard, flat, smooth level surface.
2. Adjust skid shoes by inserting a spacer of desired thickness under center of scraper blade, loosen skid shoe hardware, slide skid shoes to flat surface. Allow 1/8 in. (3 mm) between scraper blade and hard smooth surfaces. Allow 1-1/4 in. (30 mm) between scraper blade and uneven or gravel surfaces. Retighten hardware.

NOTE: Keep housing level by adjusting skid shoes equally.

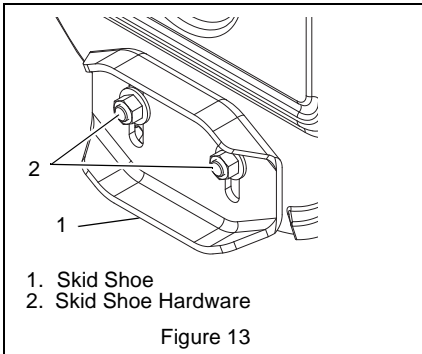

SHEAR BOLTS

(Figure 14)

IMPORTANT: Use only Ariens shear bolts for replacement. Use of any other type of shear bolt may result in severe damage to unit.

Occasionally a foreign object may enter the auger/impeller housing and jam the auger, breaking shear bolts which secure the auger to the shaft. This allows auger to turn freely on the shaft which may help prevent damage to gear case and its components.

For Replacement:

1. Align shear bolt holes in auger with shear bolt holes in the shaft.
2. Drive shear bolt through hole (if shear bolt was broken this will drive remaining part from shaft).
3. Secure shear bolt with nut.

NOTE: DO NOT overtighten the shear bolt. Tighten shear bolt to 5.8 – 12.2 lbf-ft (7.9 – 16.5 N•m).

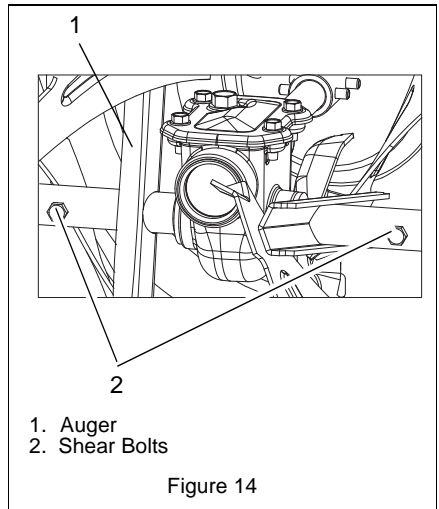

DISCHARGE CHUTE DEFLECTOR

(Figure 15)

Deflector must stay in selected position while throwing snow.

To adjust, loosen then retighten the wing knob to desired tension.

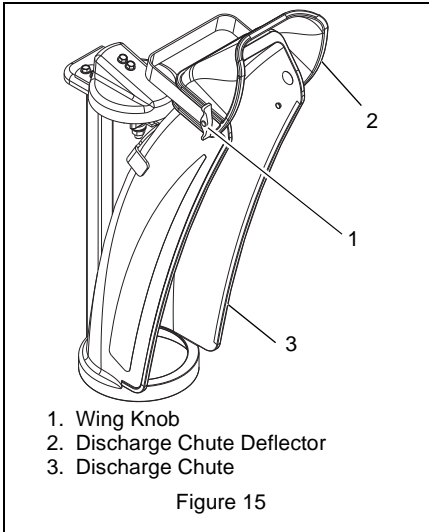

DISCHARGE CHUTE

(Figure 16)

If chute does not stay in position while operating, tighten nut on carriage bolt at pivot point to increase tension on spring.

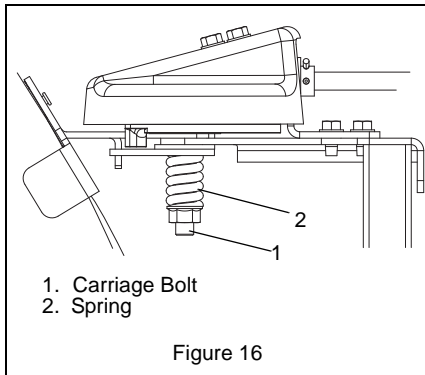

ATTACHMENT CLUTCH/BRAKE ADJUSTMENT



WARNING: IMPROPER ADJUSTMENT could result in unexpected movement of auger and impeller causing death or serious injury. AUGER / IMPELLER MUST STOP within 5 seconds when attachment clutch/impeller brake lever is released.



WARNING: Adjustment procedure requires the engine to be run with the belt cover off. **AVOID INJURY.** Read and understand the entire *Safety* section before proceeding.

Remove Attachment Cable Slack

(Figure 17 and 18)

1. Shut off engine, remove key, disconnect spark plug wire and allow unit to cool completely.
2. Loosen hardware securing belt cover to unit.

NOTE: DO NOT completely remove the hardware from unit.

3. Remove belt cover.
4. Loosen jam nut on cable adjustment barrel, and then turn the adjustment barrel down to shorten cable and remove all cable slack.

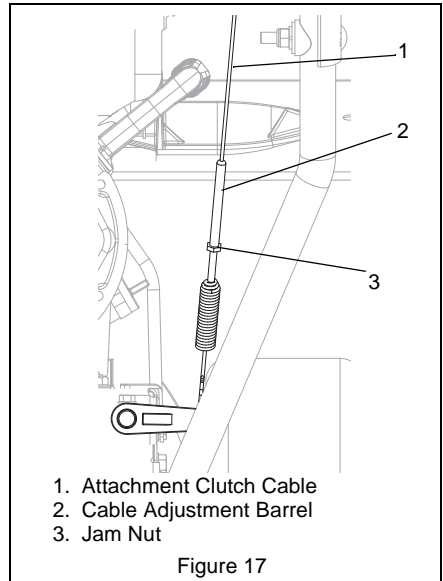

5. With the attachment clutch disengaged, check that the attachment idler arm lightly touches the frame. See Figure 18.
6. Tighten jam nut on cable adjustment barrel.

With the attachment clutch disengaged, check the attachment idler arm position here. The attachment idler arm should lightly touch the frame.

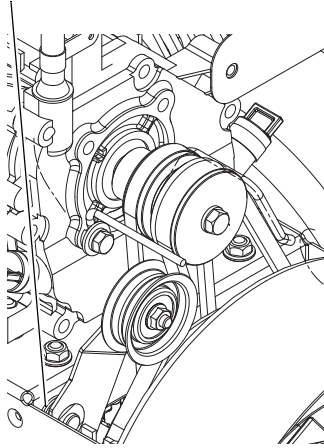
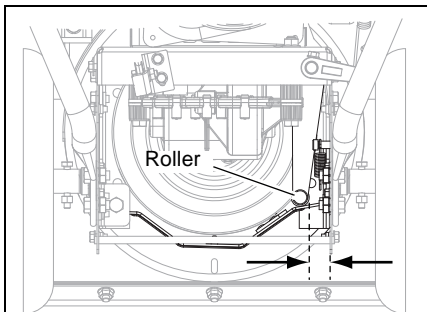

Figure 18

Check Attachment Idler Arm Roller Clearance

(Figure 19)

1. Place the unit into the service position. Remove the bottom cover.
2. With the clutch lever engaged, check the clearance between the frame and plastic roller on the lower end of the attachment idler arm.



Roller should be 1/2 – 7/8 in. (12.7 – 22.2 mm) from the frame when the attachment clutch is engaged.

Figure 19

- If roller is 1/2 – 7/8 in. (12.7 – 22.2 mm) from frame, no further adjustment is required.
- If roller is less than 1/2 in. (12.7 mm) from frame, loosen idler adjustment nut and move idler closer to the belt. Tighten adjustment nut and recheck the roller clearance.
- If roller is more than 7/8 in. (22.2 mm) from frame, loosen idler adjustment nut and move idler away from the belt. Tighten adjustment nut and recheck roller clearance.

Check Attachment Brake

(Figure 20)

1. With the attachment clutch lever disengaged, brake pad must contact attachment belt. With attachment clutch lever engaged, brake pad must be more than 1/16 in. (1.6 mm) from belt. If there is more than 1/16 in. (1.6 mm) gap, go to *Check Belt Finger Clearance* on page 21. If there is less than 1/16 in. (1.6 mm) gap, go to Step 2.

Minimum of 1/16 in. (1.6 mm) clearance

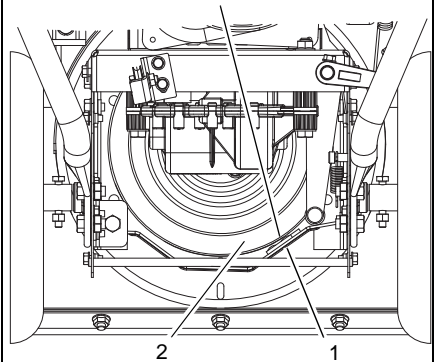

1. Brake Arm and Pad
2. Attachment Belt Pulley

Figure 20

2. If there is less than 1/16 in. (1.6 mm) gap between brake pad and belt, follow these steps:
 - a. To increase brake pad gap, loosen idler adjustment nut, and move idler away from belt. Position idler to achieve a 1/16 in. (1.6 mm) minimum brake pad gap and a 1/2 – 7/8 in. (12.7 – 22.2 mm) gap between the plastic roller and the frame.

IMPORTANT: If adjustments cannot be brought into specified ranges see your dealer for repairs.

Check Belt Finger Clearance

(Figure 23)

1. With clutch lever engaged, belt retaining fingers should be positioned as shown in Figure 23.

To adjust belt finger, loosen the bolts and move the finger to the proper position. Tighten the bolts and recheck the belt finger clearance.

2. Replace the belt cover and tighten hardware.
3. Check that auger/impeller stops within 5 seconds after attachment clutch/impeller brake lever is released.

TRACTION DRIVE CLUTCH ADJUSTMENT

(Figure 17)

1. Loosen jam nut on cable adjustment barrel.
2. Turn the adjustment barrel down to shorten cable and remove all cable slack.
3. With traction drive clutch lever disengaged, check to make sure axle and wheels turn freely.
4. Tighten jam nut on cable adjustment barrel.

ATTACHMENT DRIVE BELT REPLACEMENT

Remove Attachment Drive Belt

(Figure 21)

1. Shut off engine, remove key, disconnect spark plug wire and allow unit to cool completely.
2. Loosen the hardware securing belt cover to unit.

NOTE: DO NOT completely remove the hardware from unit.

3. Remove belt cover.
4. Remove spring clip from chute crank and separate (Figure 6).

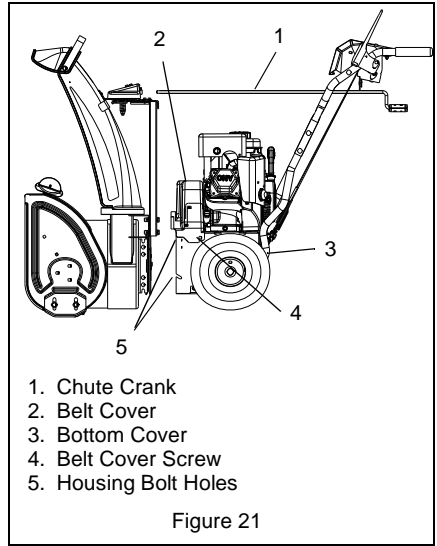

Figure 21

5. Remove belt fingers by removing cap screws mounting belt fingers to engine (Figure 22)



CAUTION: Always support Sno-Tek™ frame and housing when loosening the cap screws holding them together. Never loosen cap screws while unit is in service position.

IMPORTANT: To avoid bending bottom cover, remove the cover before separating the blower housing from the unit.

6. Support Sno-Tek™ frame and housing.
7. Remove top four cap screws and loosen lower cap screw holding blower housing to frame on each side.
8. Remove attachment drive belt from engine sheave (it may be necessary to turn engine sheave using recoil starter handle).
9. Separate housing from unit. Lower handlebar on floor.
10. Remove attachment drive belt from lower pulley.

Replace Attachment Drive Belt

(Figure 22 and 23)

1. Place new belt onto lower pulley and while holding brake out of way, tip unit together.

NOTE: Engage attachment clutch lever while connecting housing to frame to hold brake out of the way.

- Secure blower housing to frame with cap screws removed in step 7 of *Remove Attachment Drive Belt* on page 21.
- Place belt onto engine sheave.
- Replace belt fingers.

IMPORTANT: BELT FINGERS MUST BE SET as shown in Figure 23. Improper adjustment may cause impeller to rotate while attachment clutch is disengaged.

- Adjust clutch per *Attachment Clutch/Brake Adjustment* on page 19.
- Replace belt cover and tighten hardware.
- Replace chute crank into pinion gear and secure with spring clip (Figures 6 and 21).
- Run-in the drive belt according to instructions in *Run-in Attachment Belt* on page 9 and then check attachment drive clutch adjustment. See *Attachment Clutch/Brake Adjustment* on page 19.

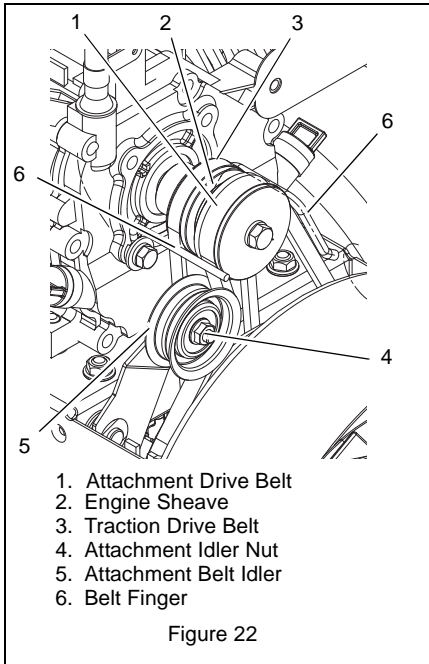
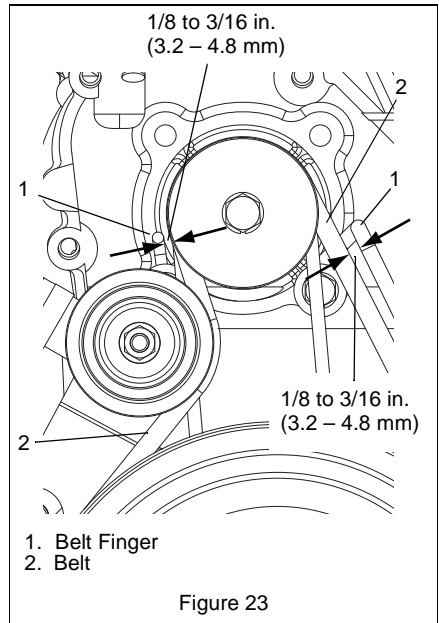

TRACTION DRIVE BELT REPLACEMENT

(Figure 24)

NOTE: Housing and frame must be tipped apart and attachment drive belt removed from engine sheave in order to change traction drive belt (Figures 21 and 22).



CAUTION: Always support Sno-Tek™ frame and blower housing when loosening the cap screws holding them together. Never loosen cap screws while unit is in service position.

- Shut off engine, remove key, disconnect spark plug wire and allow unit to cool completely.
- Remove attachment drive belt (See *Remove Attachment Drive Belt* on page 21).
- Push the traction drive belt off the engine pulley toward the engine as shown in Figure 24.

NOTE: To make belt removal easier, slowly pull the recoil starter while pushing the traction drive belt off the engine pulley.

Position the traction drive belt on the engine sheave like this when removing and installing it.

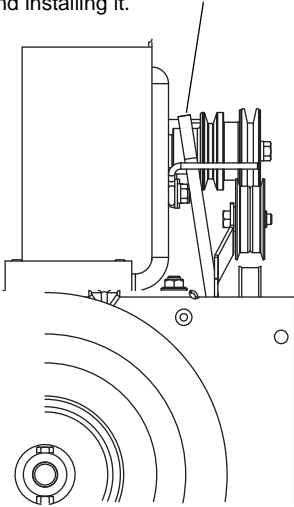

Figure 24

4. Remove and discard traction drive belt from the unit.
5. Place new traction drive belt on engine pulley between the engine and pulley groove as shown in Figure 24.
6. Place new traction drive belt on transmission pulley.
7. Push the new traction drive belt onto the groove in the engine pulley.

NOTE: Slowly pull the recoil starter while pushing the traction drive belt onto the engine pulley. Make sure the belt seats properly in the grooves of the transmission and engine pulleys.

8. Replace attachment drive belt (See *Replace Attachment Drive Belt* on page 21).

STORAGE



WARNING: AVOID INJURY. Read and understand the entire *Safety* section before proceeding.

SHORT TERM

IMPORTANT: NEVER spray unit with high pressure water or store unit outdoors.

Run with attachment clutch engaged a few minutes after each use to free unit of any loose or melting snow.

Close fuel shut-off valve.

Inspect unit for visible signs of wear, breakage or damage.

Keep all nuts, bolts and screws properly tightened and know unit is in safe working condition.

Store unit in a cool, dry protected area.

LONG TERM

Clean unit thoroughly with mild soap and low pressure water and lubricate (see *Maintenance*). Touch up all scratched painted surfaces.

Remove weight from wheels by putting blocks under frame or axle.

FUEL SYSTEM

Gasoline left in the fuel system for extended periods without a stabilizer will deteriorate, resulting in gum deposits in the system. These deposits can damage the carburetor and the fuel hoses, filter and tank. Prevent deposits from forming in the fuel system during storage by adding a quality fuel stabilizer to the fuel. Follow the recommended mix ratio found on the fuel stabilizer container.

To treat the fuel system for storage:

1. Add fuel stabilizer according to manufacturer's instructions.
2. Run engine for at least 10 minutes after adding stabilizer to allow it to reach the carburetor.

NEVER store the engine with fuel in the fuel tank inside of a building with potential sources of ignition.

SERVICE PARTS

Order the following parts through your dealer:

Part No.	Description
00036800	Ariens Hi-Temp Grease (3, 3 oz. cartridges)
21547400	Spark Plug
07200108	Impeller Belt
07200109	Stretch Fit Traction Belt
53200500	Shear Bolts
00592900	Gas Stabilizer (4 oz.)
06400920	Gear Case Seal Washer

ACCESSORIES

See your authorized Ariens dealer to add additional accessories available for your Sno-Tek™.

Part No.	Description
72000200	Slicer Bars
72600300	Composite Skid Shoe Kit
73203600	Cover

TROUBLESHOOTING

PROBLEM	PROBABLE CAUSE	CORRECTION
Engine will not crank/start.	<ol style="list-style-type: none"> 1. Fuel tank is empty. 2. Fuel shut-off valve is closed. 3. Build up of dirt and residue around governor/carburetor. 4. Key switch not in run position. 5. Engine shut off switch turned off. 	<ol style="list-style-type: none"> 1. Fill fuel tank. 2. Open fuel shut-off valve. 3. Clean area around governor/carburetor. 4. Put key switch into run position. 5. Turn on engine shut off switch.
Engine stops.	<ol style="list-style-type: none"> 1. Out of fuel. 2. Fuel shut-off valve is closed. 3. Mechanical jam in blower rake or impeller. 4. Polluted fuel supply. 5. Faulty spark plug. 6. Plugged fuel cap vent. 	<ol style="list-style-type: none"> 1. Fill fuel tank. 2. Open fuel shut-off valve. 3. Turn off engine, remove key, and wait for all moving parts to stop. Check for and remove obstruction and repair before restart. 4. Replace with clean fuel. 5. Replace or clean spark plug. 6. Replace fuel cap.
Engine problems.	<ol style="list-style-type: none"> 1. See engine manual. 	<ol style="list-style-type: none"> 1. See engine manual.
Does not drive forward.	<ol style="list-style-type: none"> 1. Traction drive cable not adjusted properly. 2. Traction belt not functioning. 	<ol style="list-style-type: none"> 1. Adjust traction drive cable. <i>See Traction Drive Clutch Adjustment</i> on page 21. 2. Repair or replace traction drive belt. <i>See Traction Drive Belt Replacement</i> on page 22.
Unit throws snow poorly or does not throw snow.	<ol style="list-style-type: none"> 1. Shear bolts broken. 2. Attachment clutch/brake not adjusted properly. 3. Impeller is frozen in place. 4. Ice or debris is obstructing auger. 5. Attachment drive belt slipping, worn or damaged. 	<ol style="list-style-type: none"> 1. Replace shear bolts (<i>see Shear Bolts</i> on page 18). 2. Adjust attachment clutch/brake (<i>see Attachment Clutch/Brake Adjustment</i> on page 19). 3. Move unit to a warm place to thaw. 4. With the engine off and auger disengaged, check for obstructions and remove. 5. Adjust or replace attachment drive belt (<i>see Attachment Clutch/Brake Adjustment</i> on page 19).

SPECIFICATIONS

Model Number	939401
Description	Sno-Tek™ 20
Engine	
Engine Model	LCT Storm Force
Gross Torque* – ft-lbs (N-m)	7.1 (9.6)
*Engine output stated in gross torque per SAE J1940 as rated by engine manufacturer	
Displacement – in. (cc)	8.3 (136)
High Idle - RPM (min)	3650 ± 50
Start	120V
Fuel Tank Capacity – qt (Liters)	2.85 (2.7)
Chute	
Chute Rotation Angle	205°
Rotation Control	2.5X Quick Turn
Deflector Control	Manual
Auger	
Snow Clearing Width – in. (cm)	20.0 (50.8)
Gear Case	Aluminum
Auger Diameter – in. (cm)	11.0 (27.9)
Impeller	
Impeller Diameter – in. (cm)	12.0 (30.5)
Impeller Speed (RPM)	1071
Impeller Tip Speed - ft/sec (m/sec)	56.1 (17.09)
Drive	
Blower Drive	4L Belt
Drive System	Clutching Wet Sump Gearbox
Speeds	1 Forward
Axle Control	Solid Locked
Pneumatic Tires – in. (cm)	10 x 4.10-4
Size and Weight	
Length – in. (cm)	51.3 (130.2)
Height – in. (cm)	43.1 (109.5)
Width – in. (cm)	22.4 (56.8)
Weight – lbs (Kg)	140 (63.5)



Sno-Thro[®], Sno-Tek[®] and Chore Performing Equipment Limited Warranty

Ariens Company (Ariens) warrants to the **original purchaser** that Ariens, Gravely, Parker, and Countax brand chore performing equipment (including Sno-Thro[®] and Sno-Tek[®] equipment) purchased on or after 1/1/2013 will be free from defects in material and workmanship for the time period noted in the chart below. Equipment put to personal use around a single household or residence is considered "Consumer Use"; equipment put to any business use (agricultural, commercial, or industrial) or used at multiple locations is considered "Commercial Use." If any product is rented or leased, then the duration of these warranties shall be 90 days after the date of purchase.

An authorized Ariens dealer (Ariens brand products), Gravely dealer (Gravely brand products), Parker dealer (Parker brand products), or Countax dealer (Countax brand products) will repair any defect in material or workmanship, and repair or replace any defective part, subject to the conditions, limitations and exclusions set forth herein. Such repair or replacement will be free of charge (labor and parts) to the original purchaser except as noted below.

Warranty Code	Product Group	Warranty Period Consumer Use	Warranty Period Commercial Use
PA	Log Splitters, Brushes, String Trimmers, Edgers	3 Years	90 Days
PB	Professional Powered Brushes	3 Years	1 Year
PC	Tillers	2 Years	90 Days
PD	Vacuums, Blowers, Sweepers, Truck Loaders, Lawn Rakes, Sprayers, Aerators, etc.	1 Year	1 Year
PE	Pressure Washer, Generators	3 Years	1 Year
SA	Professional Sno-Thro [®]	3 Years	1 Year
SB	Compact, Deluxe, Platinum, AMP [™] Sno-Thro [®] , Path-Pro [®]	3 Years	90 Days
SC	Sno-Tek [®]	2 Years	90 Days
UA	Utility Vehicles	1 Year	1 Year
N/A	Service (Replacement) Parts	90 Days (no labor)	90 Days (no labor)

Special Extensions

The chart below details special extensions to this warranty:

Warranty Code	Warranty Exception	Warranty Period	Use	Detail
SA	Cast Iron Auger Gear Case	5 Years	All	5 Years for all users including Commercial
SB	Cast Iron Auger Gear Case	5 Years	Consumer	5 Years for Consumer use; 1 Year for Commercial Use
SB	Batteries for AMP [™] Sno-Thro [®]	2 Years	Consumer	100% first year; prorated second year.

Exceptions and Limitations

The chart below details special exceptions to this warranty:

Warranty Code	Warranty Exception	Warranty Period	Use	Detail
All	Batteries	1 Year	All	Prorated
All	Belts, Muffler, Tires	None	Commercial	These components are not covered when used commercially.
All	Cloth, Plastic, and Rubber Components (Including Belts and Cables)	Maximum 2 Years	All	Warranty is limited to 2 years for consumer use. (1 year for warranty code "PD".) Except as noted above, these components are covered for defect, not for wear.
SA, SB, SC	Idlers	Maximum 2 Years	All	Warranty is limited on idlers to 2 years for consumer use.
All	Engines	See Engine Manufacturer's Warranty	All	Engines are covered by engine manufacturer's warranty. Refer to engine manufacturer's warranty statement.

Customer Responsibilities

Register the product immediately at the time of sale. If the dealer does not register the product, the customer must complete the product registration card in the literature package and return it to Ariens Company, or register the unit online at www.ariens.com, www.gravelly.com, www.countax.com or www.parkersweeper.com.

To obtain warranty service, the **original purchaser** must:

- Perform the maintenance and adjustments explained in the Owner's Manual.
- Promptly notify Ariens or an authorized Ariens, Gravelly, Parker or Countax service representative of the need for warranty service.
- Transport the product to and from the place of warranty service at owner's expense.
- Have the warranty service performed by an authorized Ariens, Gravelly, Parker or Countax service representative.

To Find an Authorized Service Representative:

In the U.S. and Canada:		
Use the dealer locator on our websites: www.ariens.com • www.gravelly.com		
Or contact us by mail or by phone:		
In the U.S., Canada, Mexico, Caribbean, Central and South America:	In Europe, Asia, Africa or the Middle East:	In Australia or New Zealand:
Ariens Company 655 W. Ryan Street Brillion, WI 54110 Phone: (920) 756 - 4688 www.ariens.com	Countax Ltd, Countax House Great Haseley, Oxfordshire, OX44 7PF Phone: 0800 597 7777 www.countax.com	Ariens Company Building 2 6 Wedgewood Rd. Hallam, Victoria 3803 Australia Phone: (03) 9796 4244 1800 335 489 www.ariens.com.au

Exclusions – Items Not Covered by This Warranty

- Parts that are not genuine Ariens, Gravely, Parker or Countax service parts are not covered by this warranty and may void the warranty.
- Damages resulting from the installation or use of any part, accessory, or attachment which is not approved by the Ariens Company for use with product(s) identified herein are not covered by this warranty.
- The following maintenance, service and replacement items are not covered by this warranty unless they are noted in the Limitations section above: lubricants, spark plugs, oil, oil filters, air filters, fuel filters, brake linings, brake arms, brake shoes, skid shoes, scraper blades, shear bolts, mower blades, mower vanes, brushes, headlights, light bulbs, knives, cutters, and single-stage impellers.
- Any misuse, alteration, improper assembly, improper adjustment, neglect, or accident which requires repair is not covered by this warranty.
- **Use of gasoline blends exceeding 10% ethanol voids any and all warranties.**
- Products are designed to the specifications in the area that the product was originally distributed. Different areas may have significantly different legal and design requirements. This warranty is limited to the requirements in the area in which the unit was originally distributed. Ariens Company does not warrant this product to the requirements of any other area. Warranty service is limited to service within the area originally distributed.
- In countries other than the United States and Canada, contact the Ariens Company dealer for warranty policies that govern within your country. Rights may vary from country to country and within any one country.
- Normal Wear: This warranty does not cover repair when normal use has exhausted the useful life of a part such as a high pressure hose, spray wand, nozzles, trigger handle, supply hoses, quick couplers, gaskets, valves, pistons, pump valve assemblies, o-rings, water and oil seals.

Special Exclusions on Utility Vehicles

The following uses void the warranty terms on Utility Vehicles (Warranty Code UA):

- Renting or leasing the utility vehicle.
- Using the utility vehicle to tow or carry loads in excess of the limits specified in the Owner/Operator Manual.
- Modifying the utility vehicle with parts and accessories that are not genuine or authorized Ariens or Gravely parts or accessories.
- Modifying the utility vehicle without express written authorization from Ariens Company.
- Operating the utility vehicle when it has not been completely and properly assembled and pre-delivered by an authorized Gravely dealer.

Disclaimer

Ariens Company may from time to time change the design of its products. Nothing contained in this warranty shall be construed as obligating Ariens Company to incorporate such design changes into previously manufactured products, nor shall such changes be construed as an admission that previous designs were defective.

LIMITATION OF REMEDY AND DAMAGES

Ariens Company's liability under this warranty, and under any implied warranty that may exist, is limited to repair of any defect in workmanship, and repair or replacement of any defective part. Ariens Company shall not be liable for incidental, special, or consequential damages (including lost profits). Some states do not allow the exclusion of incidental or consequential damages, so the above limitation or exclusion may not apply to you.

AUSTRALIAN CONSUMER LAW

The following applies solely to warranties subject to Subsection 102(1) of the Australian Consumer Law: Our goods come with guarantees that cannot be excluded by the Australian Consumer Law. You are entitled to a replacement or refund for a major failure and for compensation for any other reasonably foreseeable loss or damage. You are also entitled to have the goods repaired or replaced if the goods fail to be of acceptable quality and failure does not amount to a major failure.

DISCLAIMER OF FURTHER WARRANTY

Ariens Company makes no warranty, express or implied, other than what is expressly made in this warranty. If the law of your state provides that an implied warranty of merchantability, or an implied warranty of fitness for particular purpose, or any other implied warranty, applies to Ariens Company, then any such implied warranty is limited to the duration of this warranty. Some states do not allow limitations on how long an implied warranty lasts, so the above limitation may not apply to you.

This warranty gives you specific legal rights, and you may also have other rights which vary from region to region.



655 West Ryan Street
Brillion, WI 54110
920-756-4688
www.ariens.com

Sno-Tek Cover

Waterproof, washable and tear-resistant, this cover protects your Sno-Tek when it is not in use.



Non-Abrasive Skid Shoes

Protect the decorative surfaces around your home.

Sno-Tek LCT® Engine Maintenance Kit

Includes Ariens 32oz. 5W30 engine oil, Spark Plug, Fuel stabilizer and a spare ignition key.



Drift Cutter

Extend the bars to cut through drifts and direct snow into the auger.

*2010 Ariens Company ® Registered Trademark and ™ Trademark of Ariens Company. LCT is a registered trademark of Liquid Combustion Tech LLC. Features and specifications are subject to change without notice.



WARNING



The engine exhaust from this product contains chemicals known to the State of California to cause cancer, birth defects or other reproductive harm.

An *Ariens* Company Brand