

# Technical Data Sheet

**Model:** AB-205  
**Description:** Solar powered ventilation fan; remote mounted PV panel; gable mounted housing; natural finish  
**Revision:** 1  
**Date:** 24-Apr-10  
**DCN:** TDS-1009

Top View

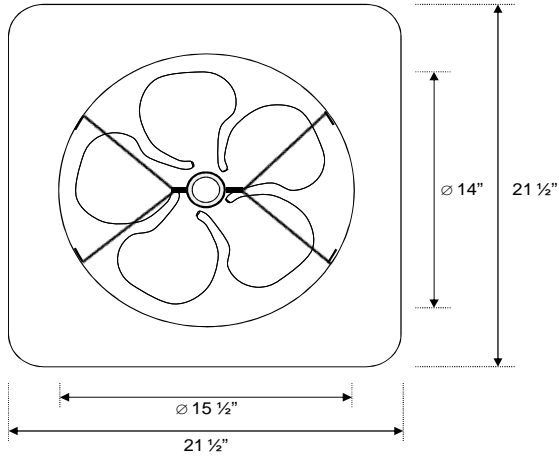

Bottom View

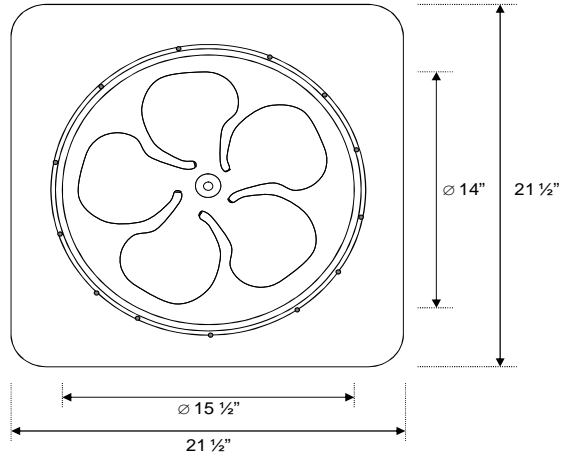

Front View

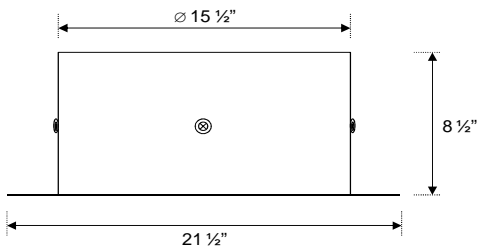

Side View

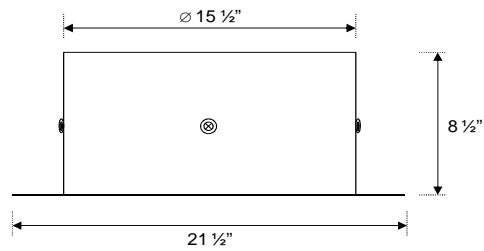

Remote Solar Panel

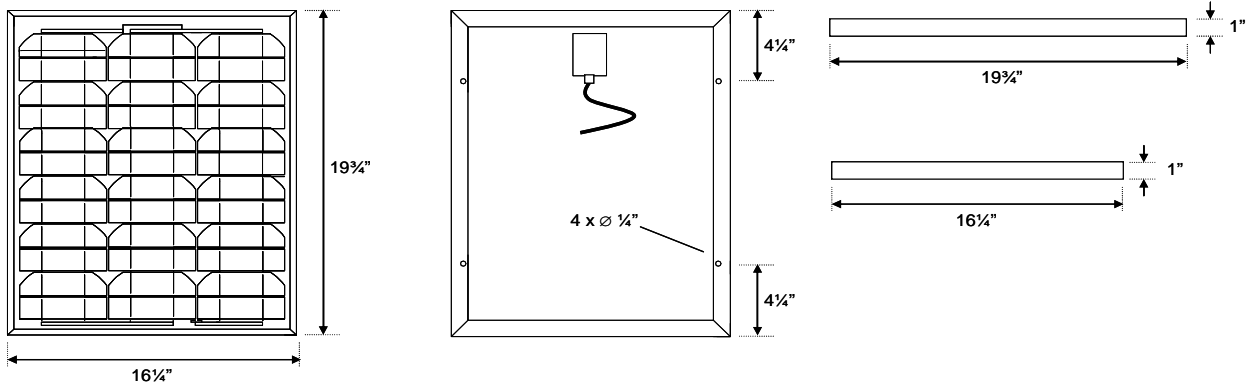

# Model AB-205 Specifications

## **Material of Construction**

Fan Housing: 24 GA Zincalume (ASTM A792 - 55% Aluminum-Zinc Alloy Coated by Hot-Dip Process)  
Rodent Screen: N/A  
Fan Blade: Proprietary 14" 5-Wing Aluminum Blade with Integrated Balanced Hub  
PV Panel: Anodized Aluminum Frame with Impact Resistant Tempered Glass  
Finish: Natural Zincalume  
Hardware: Stainless Steel Brackets & Fasteners

## **Electrical**

Motor: Proprietary 38 V variable speed DC motor  
PV Panel: Proprietary 20 W monocrystalline panel, 36 cells  
Internal Wiring: 18 AWG  
Remote Cable: SJEOOW (or equivalent) UV/Weather Resistant Cable; 15' x 18AWGX2C  
Termination: UV/Weather Resistant Quick Disconnect Plugs

## **Performance**

Air Movement: 1350 CFM @ 0.0 inH<sub>2</sub>O  
Noise Level: < 1 sones (< 30 dB)  
Wind Rating: N/A

## **Weight Load**

Fan Unit: 15 LBS  
Remote Panel: 6 LBS

