

# IN-LINE BLOWER MODEL HLB6

**For use with Broan Elite and NuTone Premier Hoods.**

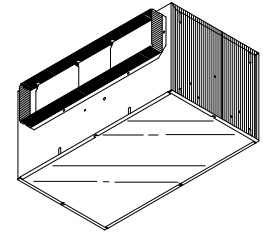

**Powerful yet quiet blower - exhausts the cooking area from a remote location.**

**FEATURES**

**BLOWER:**

- Low RPM for quiet operation
- Resilient anti-vibration mounts
- Dynamically-balanced, galvanized steel, centrifugal blower wheels for quiet, efficient performance
- Permanently lubricated, thermally protected motor
- Plug-in motor rated at 120 VAC
- Designed for continuous operation

**HOUSING:**

- Rugged galvanized steel
- 8-position mounting brackets for easy installation and greater adaptability to various mounting requirements
- Automatic backdraft damper located within exhaust duct connector
- Factory-shipped in horizontal discharge position
- May be converted to vertical discharge
- Suitable for kitchen installations

**ACCESSORIES INCLUDED:**

- 4½-inch x 18½-inch integrated duct connectors
- Two (2) 4½-inch x 18½-inch to 10-inch-round transitions
- Hanger kit - for additional installation flexibility

**SPECIFICATIONS**

Volts	Hz	Amps	CFM	Duct	Weight
120	60	2.9	600 (V) 600 (H)	4½"x18½" *	45.2 lbs.

\* Performance ratings include the addition of a 10" round transition on inlet and outlet.

**TYPICAL SPECIFICATION**

In-Line Blower shall be Model HLB6.

Unit shall have galvanized steel housing. Housing to have adjustable mounting brackets.

Blower to include hanger kit, two (2) 4½-inch x 18½-inch to 10-inch-round transitions, and 4½-inch x 18½-inch integrated duct connectors.

Automatic backdraft damper to be located within exhaust duct connector. Duct connectors, blower assembly and wiring plate shall be adjustable for either horizontal or vertical installation.

Blower unit shall be removable from housing and will have galvanized steel, centrifugal-type blower wheels. Motor to be permanently lubricated and mounted with resilient anti-vibration mounts.

Air delivery shall be no less than listed. All air ratings shall be certified by HVI. Unit to be UL and cUL listed.

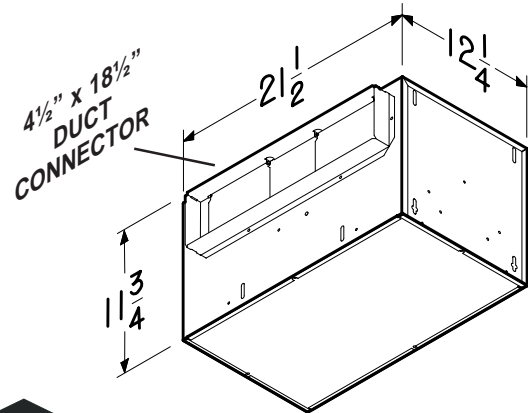

**Broan-NuTone LLC**, 926 West State Street, Hartford, Wisconsin 53027 (1-800-637-1453)  
**Broan-NuTone Canada, Inc.**, 1140 Tristar Drive, Mississauga, Ontario, L5T 1H9 (1-888-882-7626)

REFERENCE	QTY.	REMARKS	Project
			Location
			Architect
			Engineer
			Contractor
			Submitted by <span style="float: right;">Date</span>