

MODEL ZB110HL VENTILATION FAN WITH LIGHT

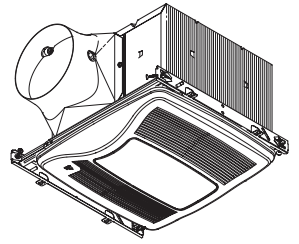

FEATURES

ULTRASMART™ DC Motor and Control Technology

- DC motor for efficiency well beyond ENERGY STAR® requirements.
- Multi-speed capability ideal for meeting ASHRAE 62.2, LEED and ENERGY STAR® for Homes requirements. Can be used to comply with CA Title 24, as well as local/spot ventilation needs.
- Powerful operation maintained over a wide range of real-world installations (CFM ratings maintained through at least 0.25" static pressure).
- Infinitely adjustable low cfm setting allows precise adjustment to prevent over-ventilating and maximize efficiency.
- Adjustable time delay sets how long fan will run on high speed before returning to a continuous lower speed.
- Rated for Continuous Operation.

ULTRASILENT™ Sound Technology

- HVI certified, best-achievable <0.3 Sone level provides nearly silent operation for a relaxing environment.
- State-of-the-art blower and duct outlet design smooths airflow.
- High tech DC motor designed for nearly silent operation.

ULTRALUCENT™ Lighting Technology

- Two, ENERGY STAR® qualified 18 watt (max) GU24, 3500K bulbs brightly illuminate room for most any task (bulbs included).
- One, 4 watt (max) C7 type night-light provides night-time convenience (bulb not included).
- Well-diffused, wide light dispersal floods room for maximum effectiveness and keeps bulbs from showing through lens.
- Enclosed reflector for minimal light visibility through the grille.

ULTRAQUICK™ Installation Technology

- Unique telescoping mounting frame fits through retrofit drywall opening to allow easy installation from the room side. No attic access needed!
- Captive screws allow for easy new construction installation.
- Mounting frame positioning tabs provide easy vertical positioning for new construction.
- Easy to insert and remove snap-in housing. No screws required!
- Easy to insert and remove snap-in blower.
- Inside or outside duct connector and knockout plate mounting provides flexibility for new construction or retrofit.

ULTRASENSE™ Humidity Sensing Technology

- Detects humidity at the ceiling where it is greatest, which minimizes reaction time.
- Automatically switches fan to maximum airflow (CFM) when either of these conditions is detected:

- Rapid to moderate humidity increase;
- Humidity above set point (50%-80% RH).
- Humidity level is set with easily accessible user adjustment.
- Can be used to comply with CALGreen standards.
- Two wire manual operation for odor control - Boosts fan to maximum airflow (CFM) when power line through wall switch is cycled ON, OFF and back ON.
- After humidity has stabilized and is below set point or after boosted through power line cycling, fan operates at maximum airflow (CFM) until UltraSmart™ user adjustable (5 to 60 minutes) time delay set point is reached then fan reduces to continuous airflow (CFM) level.

U.L. Listed for use over bathtubs and showers when connected to a GFCI protected branch circuit (ceiling mount only).

U.L. Listed for use in insulated ceilings (Type IC).

Use only ON/OFF switch, mechanical timer or relay-switched control.

3-year warranty on product, 1-year warranty on bulbs.

DIMENSIONS (Inches)

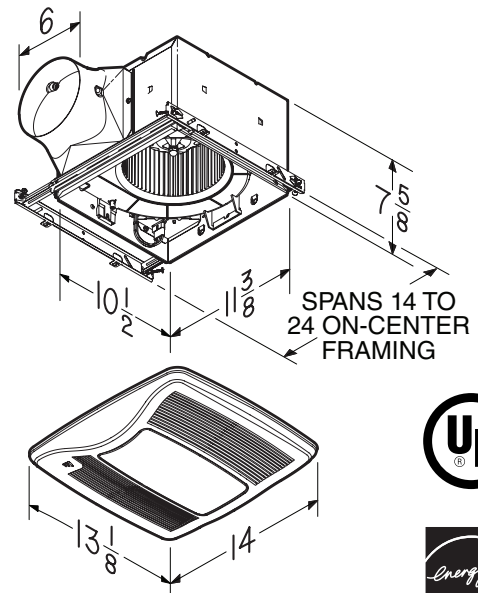

Broan-NuTone LLC Hartford, Wisconsin www.broan.com 800-558-1711

REFERENCE	QTY.	REMARKS	Project
			Location
			Architect
			Engineer
			Contractor
			Submitted by
			Date



PERFORMANCE SPECIFICATIONS

MODEL ZB110HL VENTILATION FAN WITH LIGHT

ELECTRICAL & WEIGHT

HVI PERFORMANCE

Airflow Rate Setting (CFM)	6" Duct				
	0.1 Ps - Static Pressure (inH2O)				0.25 Ps
	Airflow (CFM)	Sound (Sones)	Power (Watts)	Efficacy (CFM/Watt)	Airflow (CFM)
110	110	< 0.3	9.3	11.8	110
100	100	< 0.3	7.9	12.7	100
90	90	< 0.3	7.1	12.7	90
80	80	< 0.3	6.6	12.1	80
70	70	< 0.3	5.8	12.1	70
60	60	< 0.3	5.2	11.5	60
50	50	< 0.3	4.7	10.6	50
40	40	< 0.3	4.2	9.5	40
30	30	< 0.3	3.9	7.7	30



HVI-2100 CERTIFIED RATINGS comply with new testing technologies and procedures prescribed by the Home Ventilating Institute, for off-the-shelf products, as they are available to consumers. Product performance is rated at 0.1 in. static pressure, based on tests conducted in a state-of-the-art test laboratory. Sones are a measure of humanly-perceived loudness, based on laboratory measurements.

Volts	Hz	Amps*	Shipping Weight (lbs.)
120	60	1.0	13.8

* Total connected load



FAN CAPABILITY

