



Delta BreezSlim
Perfectly quiet. Perfectly green.

Delta BreezSlim Series

VFB050B3A1	50 CFM Single Speed
VFB070B3A1	70 CFM Single Speed
VFB070B3X1	50/70 CFM Dual Speed

Project Pack Components

VFB000B3A1F	Fan Housing Can
VFB050B3A1F	50 CFM Motor/Grille Pack
VFB070B3A1F	70 CFM Motor/Grille Pack
VFB070B3X1F	50/70 CFM Motor/Grille Pack

Extraordinary power and performance in a compact design.

The Delta BreezSlim Ventilation Fan marks a new achievement in bathroom ventilation for green construction. Combines record low power consumption of 6.4 Watts and quiet operation down to 1.0 sone, the lowest ever in a 7.5" x 7.25" bath fan. BreezSlim series fans are designed for easy retrofit into existing bathrooms, multi-family housing and new construction, either ceiling or wall mountable.

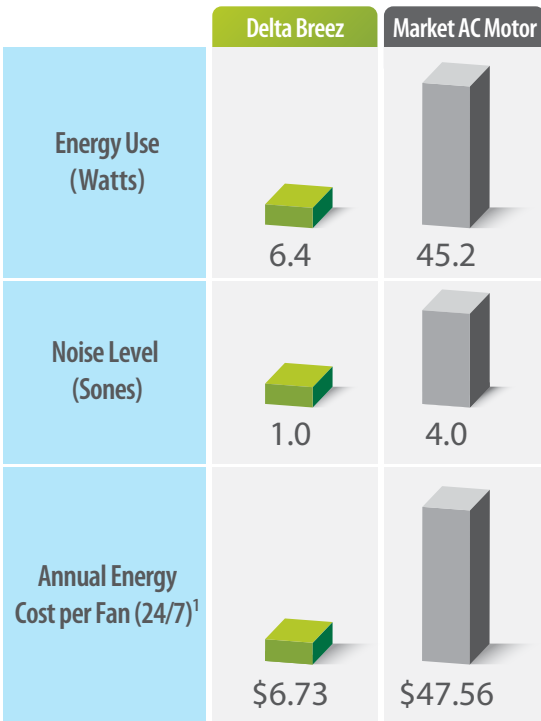

Innovative DC brushless motor design for long life, low noise, and low power consumption.

- Energy savings up to 85%²
- 1 Sone – the quietest ever in a 7.5" x 7.25" bath fan
- Exceeds Energy Star requirement by 600% in energy efficiency³

Project Pack Components Available

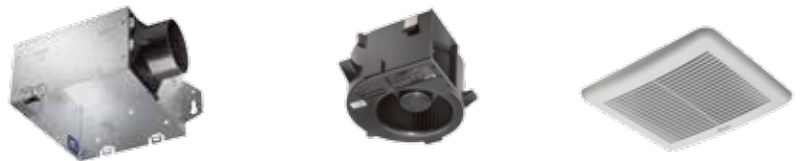

¹ Calculations based upon U.S. average retail electricity at and HVI testing labs. Actual results may vary.

² Based upon BreezSlim VFB050B3A1 vs. market AC motor fan.

³ Based upon Energy Star criteria for residential ventilating fans.



Specifications

Delta BreezSlim
Perfectly quiet. Perfectly green.

The Delta BreezSlim series ventilation fans deliver extraordinary power and performance in a compact design, especially suited for challenging space requirements. Can be either ceiling or wall mounted.

Fan Housing

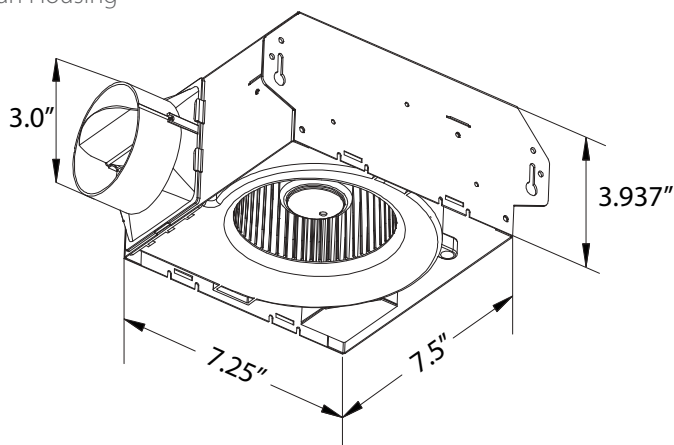

Fan Grille

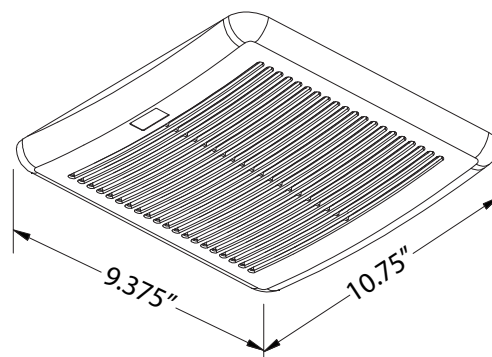

Delta BreezSlim Series	VFB050B3A1		VFB070B3A1		VFB070B3X1			
Static Pressure (Inches w.g.)	0.1	0.25	0.1	0.25	0.1	0.25	0.1	0.25
Air Flow (CFM)	50	36	70	54	50	36	70	54
Sones	1.0	1.2	2.0	1.5	1.0	1.2	2.0	1.5
Power Consumption (Watts)	6.4	6.3	13.1	11.5	6.4	6.3	13.1	11.5
Energy Efficiency (CFM/Watt)	8.9	6.5	5.8	5.0	8.9	6.5	5.8	5.0
Current (Amps)	0.18 @ 120 Vac		0.29 @ 120 Vac		0.18 @ 120 Vac		0.29 @ 120 Vac	
Power Rating (Volts/Hz)	120/60		120/60		120/60			
Duct Diameter	3"		3"		3"			
Dual Speed	N/A		N/A		Yes			
Mounting Opening	7.25" x 7.5"		7.25" x 7.5"		7.25" x 7.5"			
Mounting Depth	3.937"		3.937"		3.937"			
Grille Size	9.375" x 10.75"		9.375" x 10.75"		9.375" x 10.75"			
Shipping Gross Weight (Lbs)	4.75		4.75		4.75			
cUL Tub/Shower Enclosure	Yes		Yes		Yes			
Washington State VIAQ Code	Yes		Yes		Yes			
California Title 24 Compliant	Yes		Yes		Yes			
Mfg in ISO 9001 Certified Factory	Yes		Yes		Yes			
Energy Star Certified	Yes		Yes		Yes			
Warranty (Years)	3		3		3			

Design and specifications subject to change without notice.

