

# EL527H18; EL527H18-HP EL52718-277; EL527HE18; EL527H18D

5" Compact Fluorescent Vertical Light with integral fluorescent ballast. Housing adjusts 1 3/8" to accommodate ceiling thicknesses.

## PROJECT INFORMATION:

Project Name: \_\_\_\_\_

Fixture Type: \_\_\_\_\_

Date: \_\_\_\_\_

## DIMENSIONS

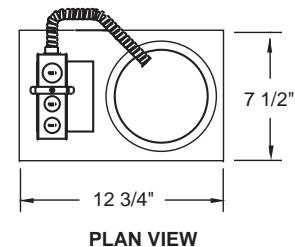
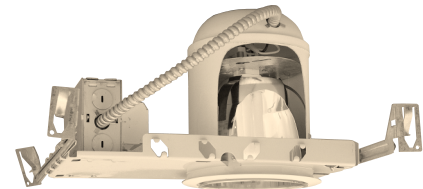
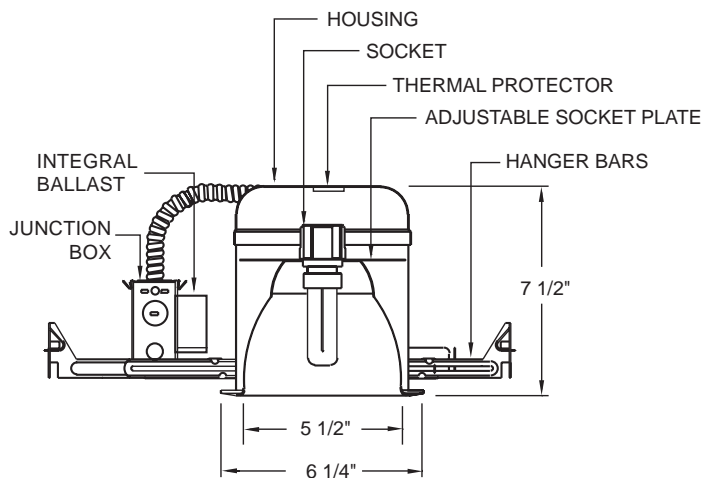

## PRODUCT SPECIFICATIONS

**Housing Features:** Integral thermal protector guards against improper lamping. Single wall construction.

Adjustable socket bracket allows the use of different lamp types and sizes as well as proper and consistent lamp positioning.

**Lamp:** Designed for (1)18W Quad Tube or Twin Tube compact fluorescent lamp

**Reflector:** Clear or gold aluminum reflector.

**Trim Ring:** Polycarbonate trim ring, designed to conceal ceiling cutout.

**EL527H18** = (1) 18W 2 PIN PL/QUAD  
120V N.P.F. BALLAST

**EL527R18-HP** = (1) 18W 2 PIN PL/QUAD  
120V H.P.F. BALLAST

**EL527H18-277** = (1) 18W 2 PIN PL/QUAD  
277V H.P.F. BALLAST

**EL527HE18** = (1) 18W 4 PIN QUAD  
120/277V H.P.F. ELECTRONIC BALLAST

**EL527H18D** = (1) 18W 4 PIN QUAD  
120/277V H.P.F. DIMMABLE BALLAST

## INSTALLATION

**Junction Box:** Pre-wired junction box provided with 1/2" and 3/4" knockout. U.L. listed/C.U.L. listed: for through branch wiring, maximum (8) NO. 12 AWG branch circuit conductors (4 in, 4 out). Junction box provided with removable access plates.

**Mounting:** Hanger bars span 24" joists and can be repositioned 90 degrees.

**Mounting Frame:** Stamped steel material and painted for corrosion resistance.

### Labels:

- U.L. listed for damp locations.
- U.L. listed for feed through.

## CATALOG NUMBER

**Example:** EL527H18-ELA599SC

See trims page for variety of trims available.