

ELKAY[®]

SPECIFICATIONS

Gourmet Undermount Sinks Model SCUH1012 Series

GENERAL

High quality single bowl sink is formed of type 304 (18-8) nickel bearing stainless steel material.

SCUH1012SH hammered mirror finish

SCUH1012SM mirror finish

DESIGN FEATURES

Bowl Depth: 6-1/2" (165mm).

Coved Corners: 3" (76mm) vertical and horizontal radii.

Underside: Fully undercoated to reduce condensation and dampen sound.

OTHER

Drain Opening: 3-1/2" (89mm).

Note: All Elkay undermount sinks are designed to affix easily to the underside of any solid surface countertop.

Sink complies with ASME A112.19.3-2008 / CSA B45.4-08.



These sinks are listed by the International Association of Plumbing and Mechanical Officials as meeting the requirements of the Uniform Plumbing Code and the National Plumbing Code of Canada.

OPTIONAL ACCESSORIES

Cutting Board: CB912

Drain: LK99

SINK DIMENSIONS*

Model Number	Overall		Inside Bowl			Cutout in Countertop	Minimum Cabinet Size
	L	W	L	W	D		
SCUH1012SH	12 (305mm)	14 (356mm)	10 (254mm)	12 (305mm)	6½ (165mm)	See Template**	15 (381mm)
SCUH1012SM	12 (305mm)	14 (356mm)	10 (254mm)	12 (305mm)	6½ (165mm)		15 (381mm)

*Length is left to right. Width is front to back.

**Template 74180290 and countertop mounting clips are packed with every sink.

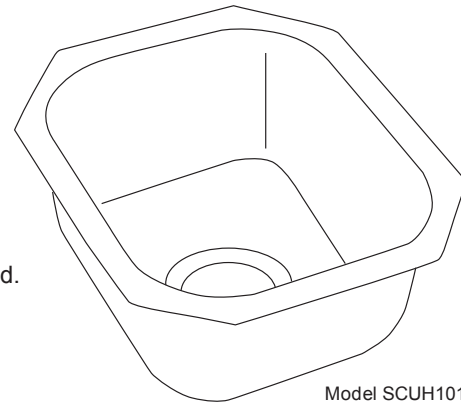

Model SCUH1012

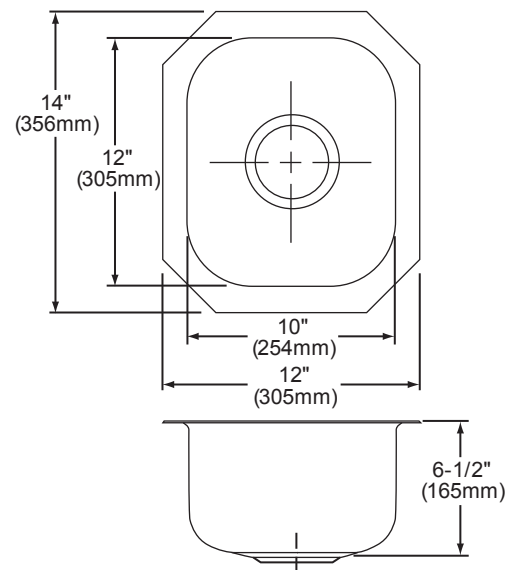
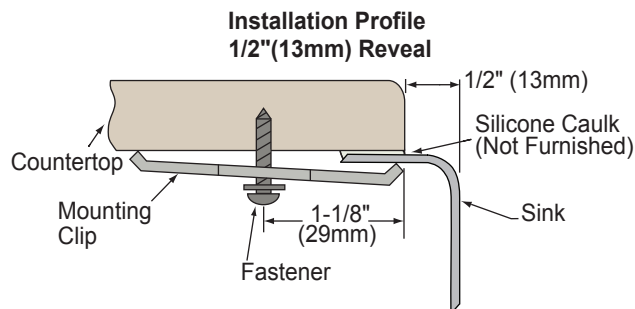

Model SCUH1012

In keeping with our policy of continuing product improvement, Elkay reserves the right to change product specifications without notice. Please visit elkayusa.com for most current version of Elkay product specification sheets.

This specification describes an Elkay product with design, quality and functional benefits to the user. When making a comparison of other producers' offerings, be certain these features are not overlooked.

Elkay

elkayusa.com

2222 Camden Court
Oak Brook, IL 60523

Printed in U.S.A.
©2011 Elkay

(Rev. 8/11) 1-174D