

EDUR15

EZSET®

8000 Series EXIT DEVICE

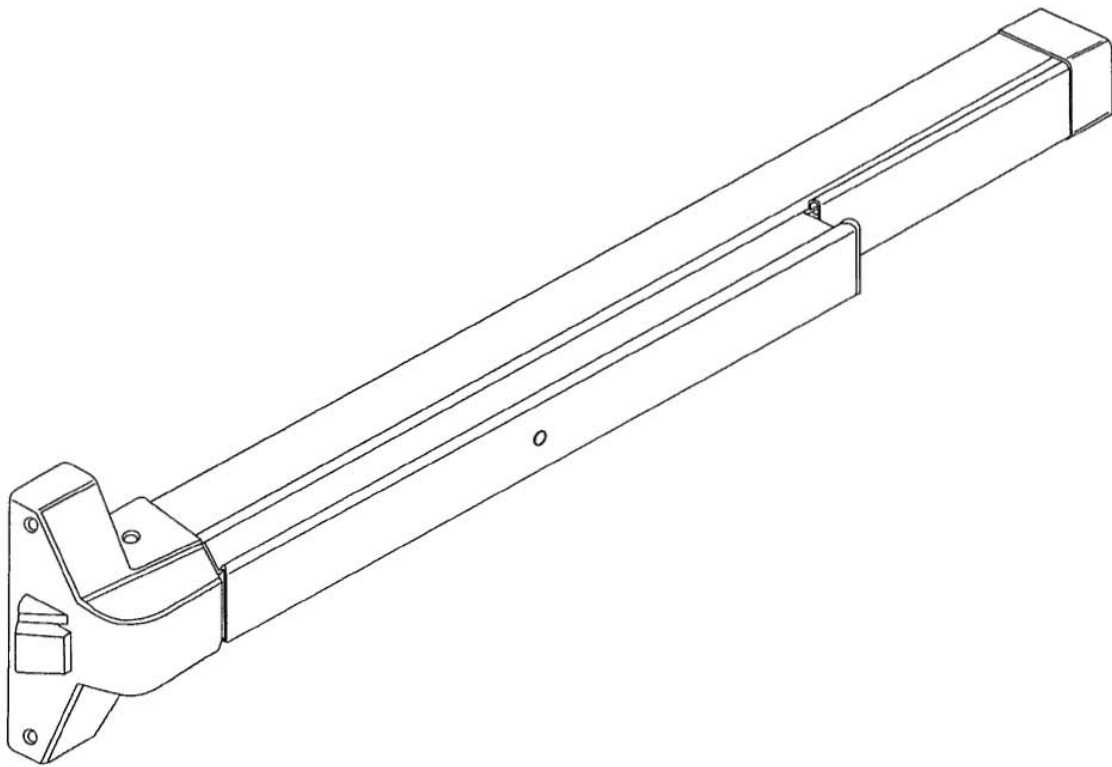

INSTALLATION INSTRUCTIONS

2010.03A

A IDENTIFICATION OF PARTS

IF DOOR IS LESS THAN 36", REMOVE END COVER AND CUT SECTION "A" TO DESIRED LENGTH.

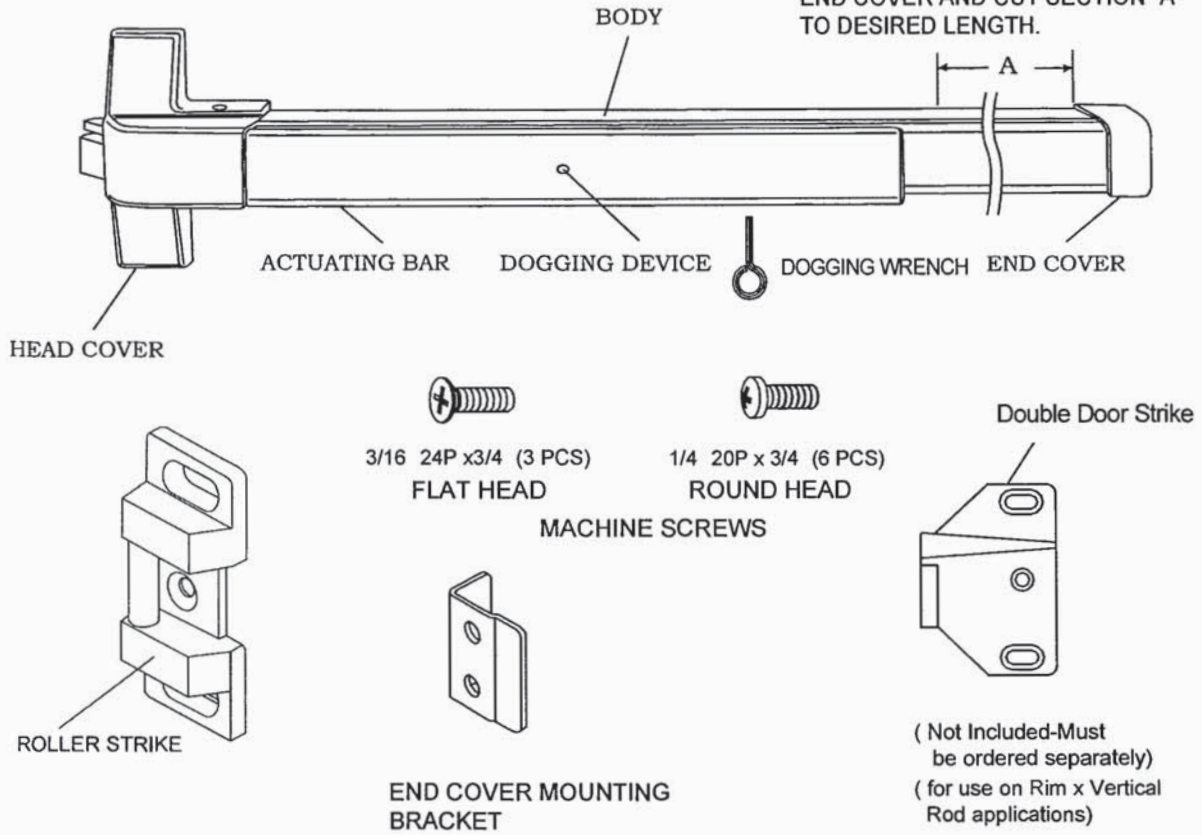

B TYPE OF INSTALLATION

A. SINGLE DOOR

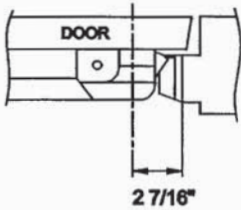

B. DOUBLE DOOR WITH MULLION

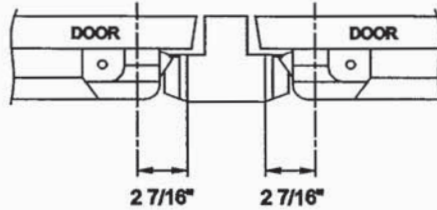

C. DOUBLE DOOR WITHOUT MULLION

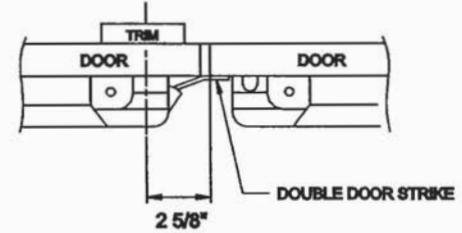

C DRILL HOLES

1. USE TEMPLATE ENCLOSED TO MARK DOOR FACE AND DRILL HOLES IN ACCORDANCE WITH THE DIAMETERS SUGGESTED

2. "B" LENGTH SHOULD BE MEASURED FROM THE CENTER OF CYLINDER HOLE TO THE END OF THE BODY

DRILL & TAP FOR (6) 1/4 x 20 MACHINE SCREWS FOR EXIT DEVICE AND DRILL & TAP FOR (3) 3/16 x 24P MACHINE SCREWS FOR ROLLER STRIKE.

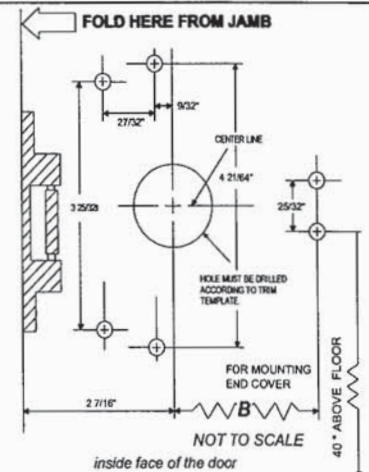
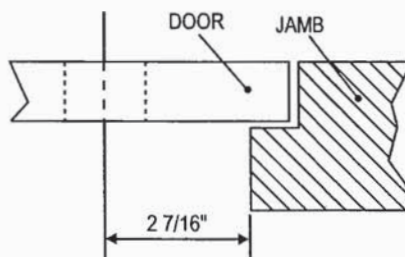

D INSTALL KEY CYLINDER

If required or skip to step E

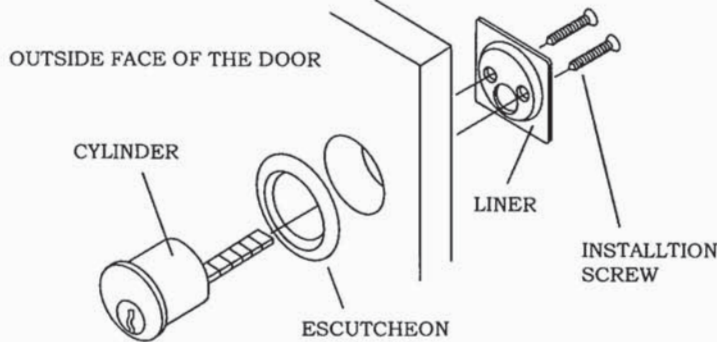

1. INSERT THE CYLINDER INTO THE HOLE ON THE DOOR
2. KEEP THE TAILPIECE HORIZONTAL
3. TIGHTEN THE SCREWS

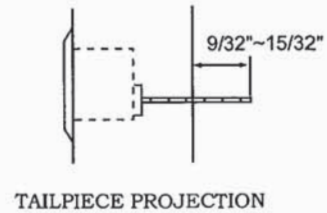

E INSTALL BODY

1. REMOVE THE HEAD COVER AND THE SCREWS ON THE END COVER
2. ALIGN THE SCREW HOLES WITH THE HOLES ON THE DOOR
3. TIGHTEN THE SCREWS ON THE BODY AND THE LINING OF END COVER

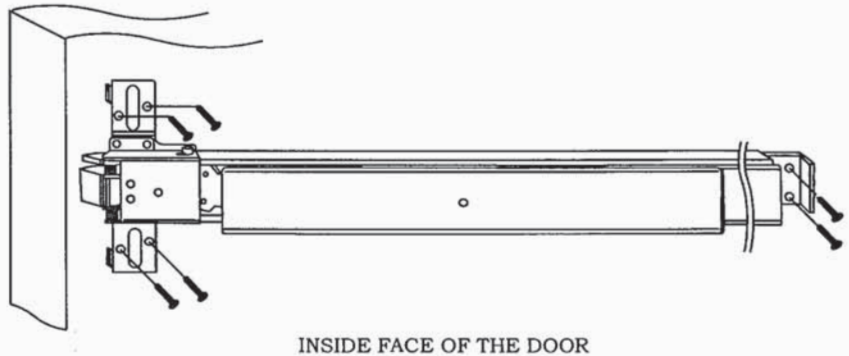

F PUT ON BOTH HEAD AND END COVER

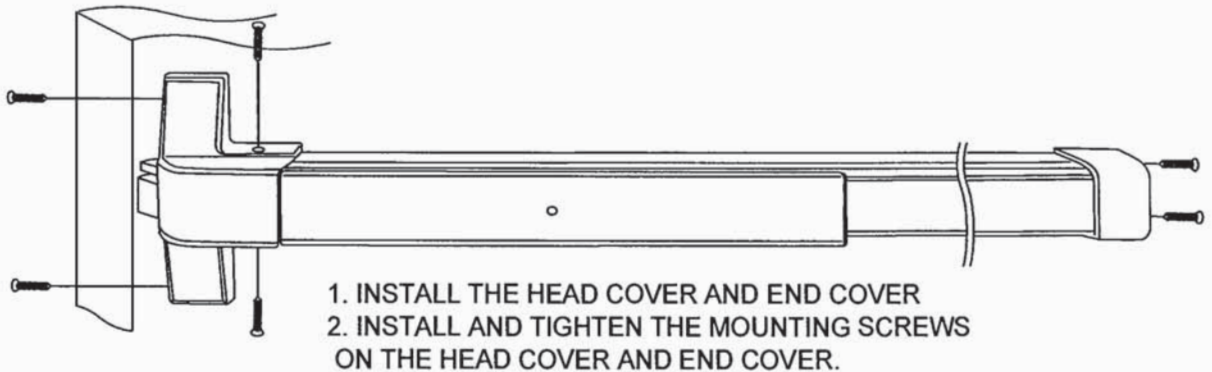

G INSTALL ROLLER STRIKE

1. CLOSE DOOR AND MARK LATCHBOLT ON DOOR JAMB WITH A PENCIL.
2. PLACE ROLLER STRIKE ON DOOR JAMB. ALIGN CENTER OF ROLLER STRIKE WITH CENTER OF PENCIL MARK. THEN ALIGN OUTSIDE EDGE OF ROLLER STRIKE WITH OUTSIDE EDGE OF DOOR JAMB.

3. MARK IN THE CENTER OF 2 ADJUSTABLE SLOT AND DRILL $5/32$ " PILOT HOLE AND $3/16$ "-24P THREAD AT MARKED LOCATIONS THEN TIGHTEN WITH $3/16$ "-24P FLAT HEAD SCREWS. OPEN AND CLOSE DOOR TO CHECK IF LATCHBOLT CAN EXTEND AND RETRACT PROPERLY. ADJUST ROLLER STRIKE IF NECESSARY.
4. WITH THE ROLLER STRIKE IN FINAL POSITION, DRILL AT THE CENTER $5/32$ " PILOT HOLE AND $3/16$ "-24P THREAD AND TIGHTEN WITH $3/16$ "-24P FLAT HEAD

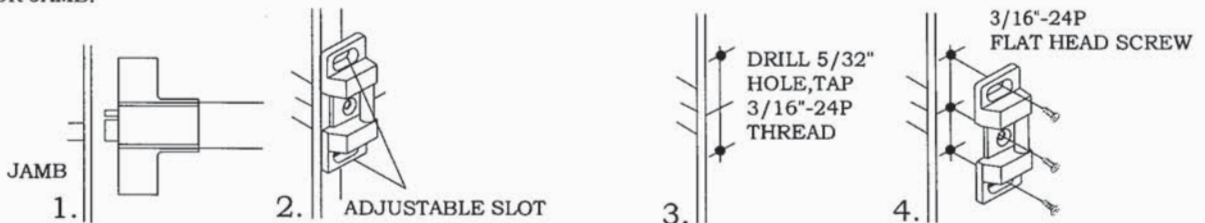

H OPERATION TEST

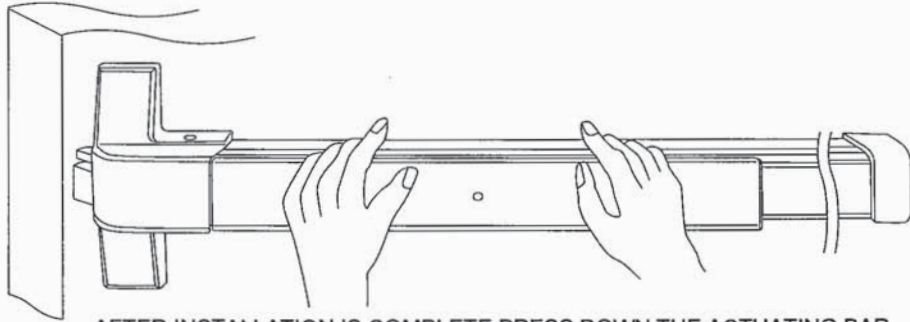

AFTER INSTALLATION IS COMPLETE PRESS DOWN THE ACTUATING BAR TO MAKE SURE THE DOOR OPENS AND CLOSES/LATCHES CORRECTLY. MAKE ANY ADJUSTMENTS AS NEEDED.

NOTICE:

TO EXTEND THE LIFE OF THIS PANIC DEVICE, LOCK THE LATCH IN THE RETRACTED POSITION WHEN DOOR IS IN CONTINUOUS USE.

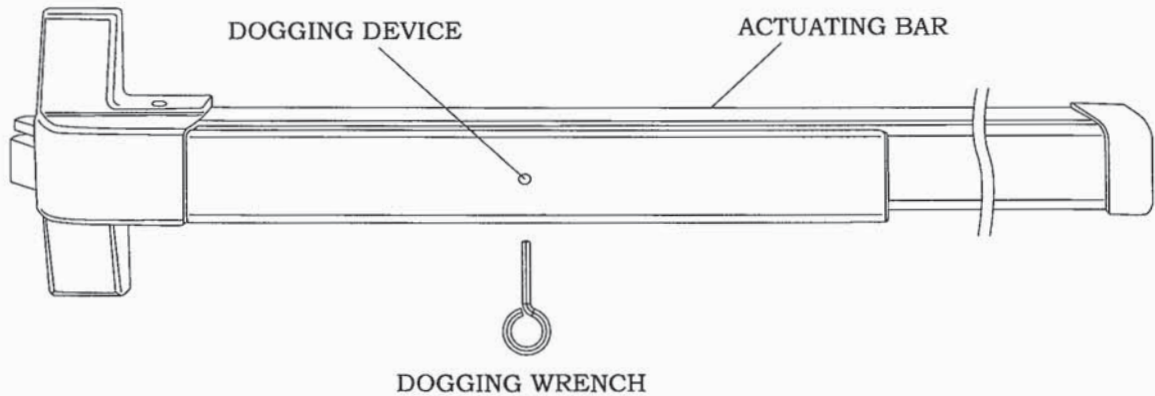

TO LOCK

HOLD ACTUATING BAR DOWN. TURN DOGGING DEVICE COUNTER CLOCKWISE WITH DOGGING WRENCH.

TO UNLOCK

HOLD ACTUATING BAR DOWN. TURN DOGGING DEVICE DEVICE CLOCKWISE WITH DOGGING WRENCH.

TEMPLATE FOR INSTALLING PANIC EXIT DEVICE

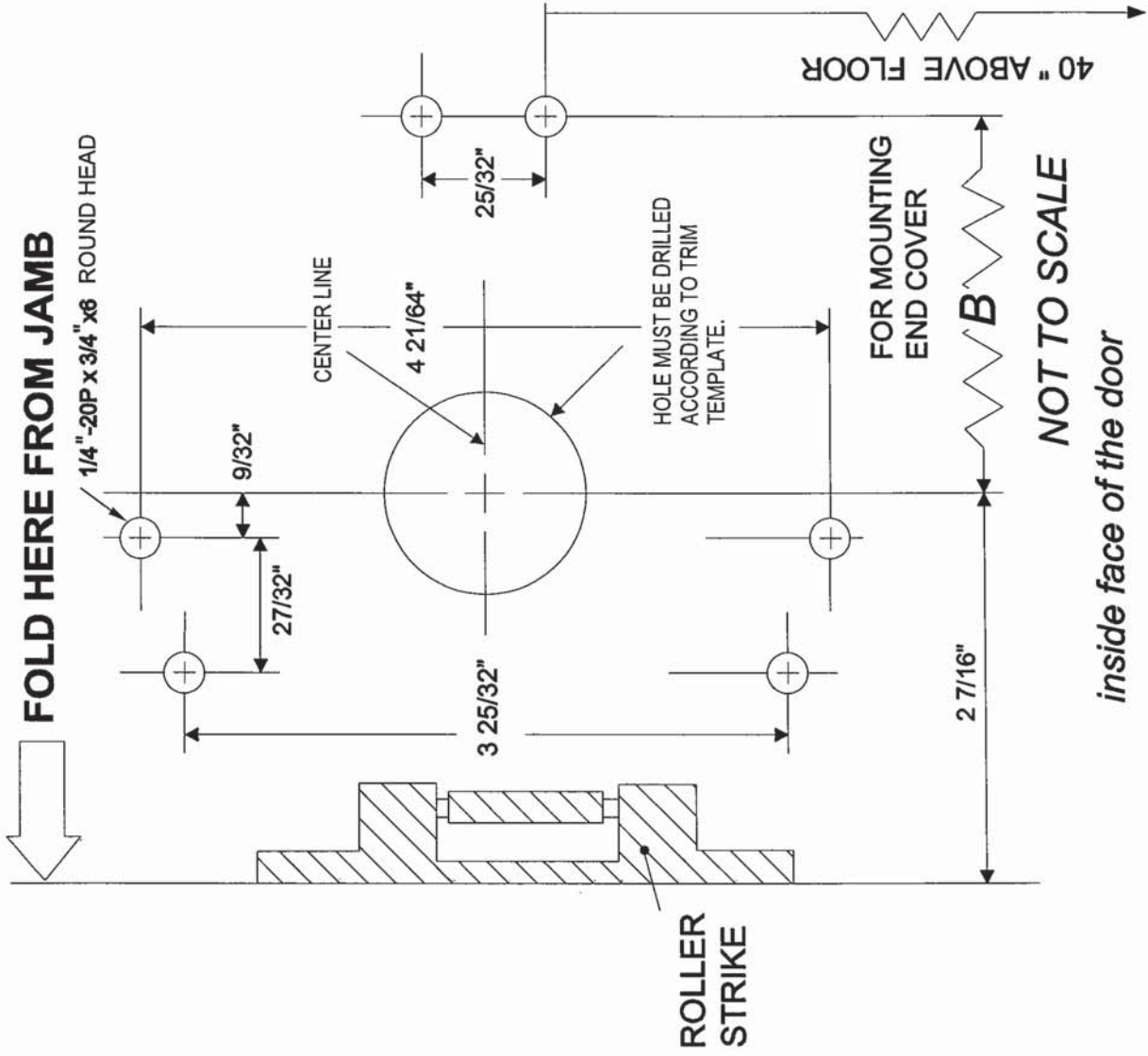
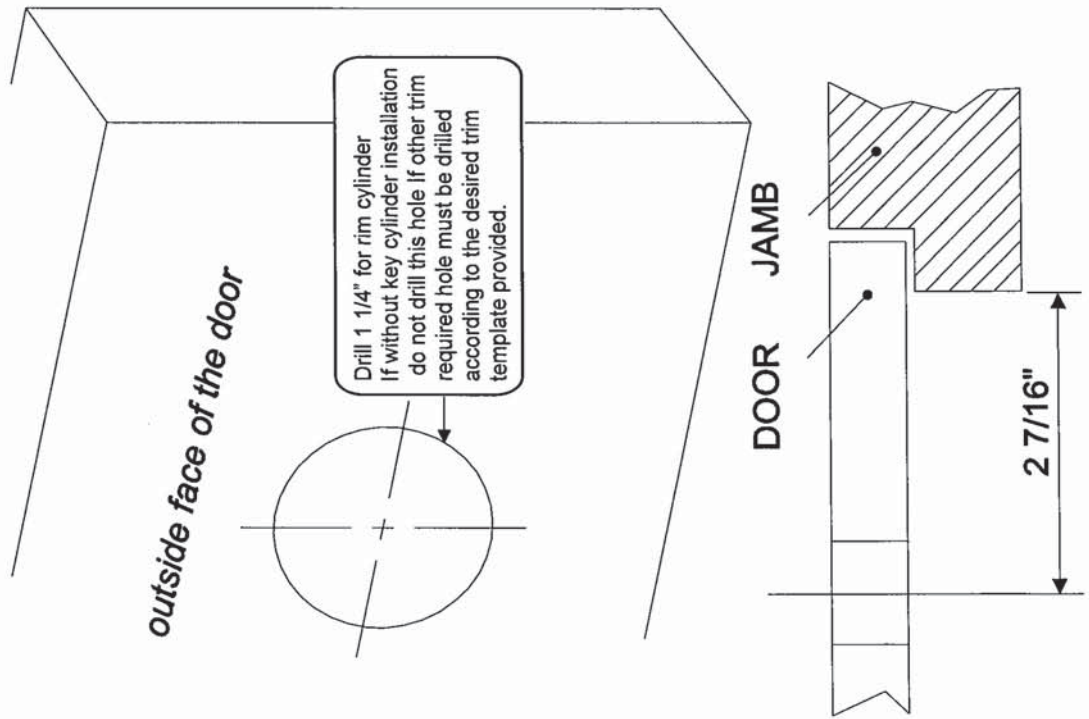

EDUR15 Series (UL Listed)-Drill & tap for (6) 1/4"x20 machine screws for Exit Device and Drill & tap for (3) 3/16"x24 machine screws for Roller Strike.