



## *Fusion 100/200 Series Deadbolts*

---

### **Performance Criteria –**

- Meets Most ANSI 156.5 Grade 2 Criteria
- U.L. Latch Availability
- Double and Single Cylinder Options Available

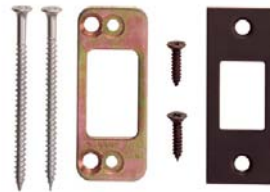
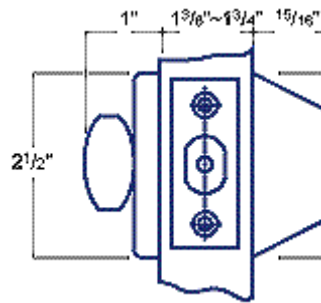

### **Additional Features and Benefits –**

#### **Security –**

- Full 1" Throw for the Dead-locking bolt
- Mushroom shaped Cylinder Pins for Added Pick Resistance
- Hardened Inner Steel Rolling Pin in Bolt for Saw and Cutting Resistance
- Oversized 3-1/2" Strike Plate with 3" Staggered Screws Positions for Forced Entry Resistance

#### **Durability -**

- All Metal Construction
- Weather Exposed Components are Brass
- Nickel Plated over Brass Keys

#### **Installation and Operation –**

- Can be keyed alike with all Fusion Entry Products.
- SC1 Keyway is Standard Key System
- Cylinder is removable for re-keying by Owner
- Reversible Mounting for Varying Handing on LH and RH Doors
- Adjustable for Varying Door Thickness 1-3/8" and 2"
- 2-3/8" or 2-3/4" Latch Backsets Available