

INSTRUCTION MANUAL

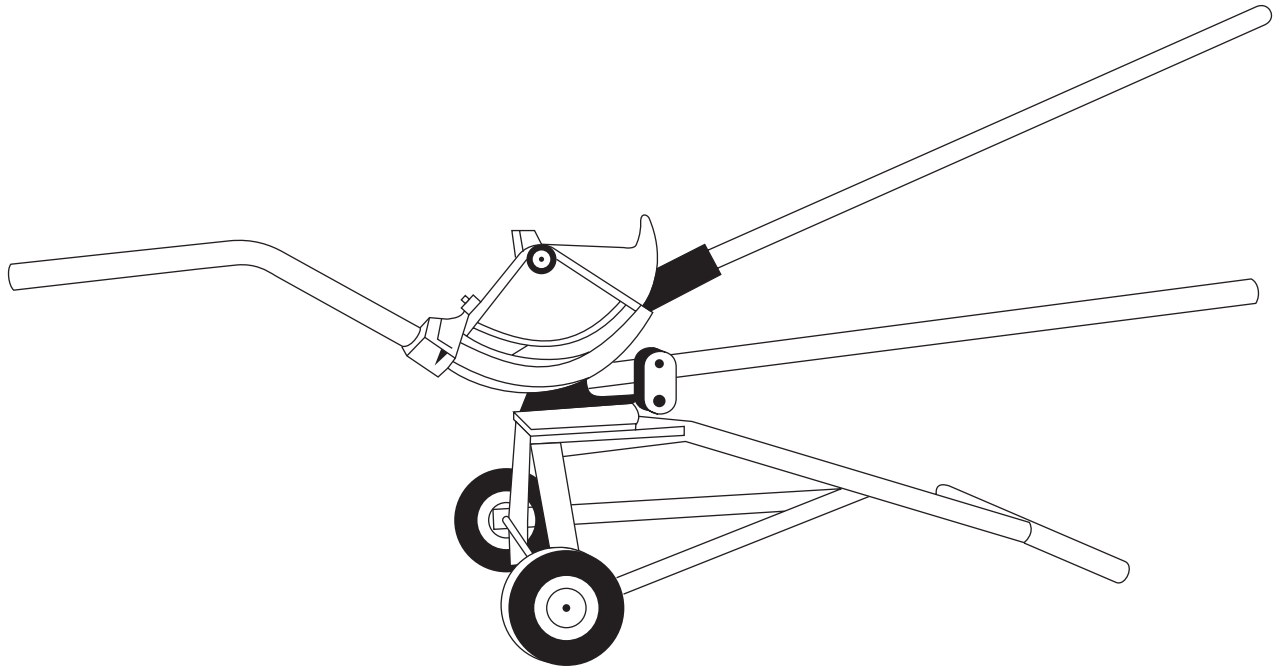

1801 Ratchet Bender

**For 1-1/4", 1-1/2" Rigid Conduit, IMC and Schedule 40 Pipe
Serial Code - RS**



Read and understand all of the instructions and safety information in this manual before operating or servicing this tool.

Description

The 1801 Ratchet Bender is a manually powered bender intended to bend 1-1/4" and 1-1/2" IMC (intermediate metallic conduit), Rigid Conduit and Schedule 40 Pipe.

Safety

Safety is essential in the use and maintenance of Greenlee tools and equipment. This instruction manual and any decals on the tool provide information for avoiding hazards and unsafe practices related to the use of this tool. Observe all of the safety information provided.

Purpose

This instruction manual is intended to familiarize all personnel with the safe operation and maintenance procedures for the Greenlee 1801 Ratchet Bender.

Keep this manual available to all personnel.

Replacement manuals are available upon request at no charge.

All specifications are nominal and may change as design improvements occur. Greenlee Textron Inc. shall not be liable for damages resulting from misapplication or misuse of its products.

KEEP THIS MANUAL

IMPORTANT SAFETY INFORMATION



SAFETY ALERT SYMBOL

This symbol is used to call your attention to hazards or unsafe practices which could result in an injury or property damage. The signal word, defined below, indicates the severity of the hazard. The message after the signal word provides information for preventing or avoiding the hazard.

⚠️ DANGER

Immediate hazards which, if not avoided, **WILL** result in severe injury or death.

⚠️ WARNING

Hazards which, if not avoided, **COULD** result in severe injury or death.

⚠️ CAUTION

Hazards or unsafe practices which, if not avoided, **MAY** result in injury or property damage.

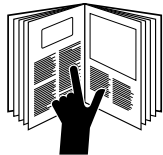

⚠️ WARNING

Read and understand all of the instructions and safety information in this manual before operating or servicing this tool.

Failure to observe this warning could result in severe injury or death.

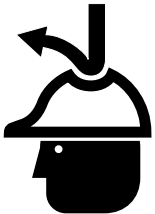

⚠️ WARNING

Do not leave the ratchet handle in the UP position when the bender is not in use. A handle left in the UP position could fall unexpectedly.

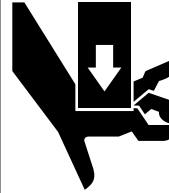

⚠️ WARNING

Pinch points: Keep hands away from moving parts and conduit when bending.

Failure to observe this warning could result in severe injury.

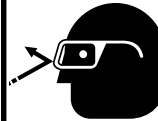

⚠️ WARNING

Wear eye protection when using this tool.

Failure to wear eye protection could result in serious eye injury from flying debris.

⚠️ CAUTION

- Keep the conduit under control when unloading the bender. Conduit may fall and strike the operator or nearby personnel.
- Maintain a firm grip on the handle when bending. Springback of the conduit may not allow the ratchet to fully engage, causing the handle to spring upward suddenly.
- Remove the handle and conduit before moving the bender. Maintain a firm grip with both hands on the frame T-handle to prevent the bender from tipping over.
- Inspect the bender before each use. Replace any worn, damaged, or missing items with Greenlee replacement parts. A damaged or improperly assembled tool can break and strike nearby personnel.
- Use proper lifting practices when lifting the bender. The bender weighs over 100 lbs. and requires more than one person to lift.

Failure to observe these precautions may result in injury or property damage.

⚠️ CAUTION

Use this product for the manufacturer's intended purpose only. Use other than which is described in this manual may result in injury and property damage.

Setup

1. Park the bender on a flat, firm surface, such as a concrete floor.
2. Insert a 5-ft length of 1-1/4" rigid conduit into the lever unit. This is the bending handle.

Operation

1. Raise the handle completely to release the ratchet mechanism. Manually rotate the shoe fully counter-clockwise. Lower the handle.
2. Slide the conduit to be bent over the pipe support roller, into the shoe groove, and past the outside edge of the pipe hook.
3. Line up the bending mark with the front edge of the pipe hook.
4. Lift the handle until the ratchet clicks once. Push the handle down. Repeat until the bend is complete.

Note: The bending degree indicator will not compensate for springback.

5. Raise the handle back to the starting position. Lift tail of pipe to return shoe to load position.
6. Remove the conduit from the bender.
7. Lower the handle.

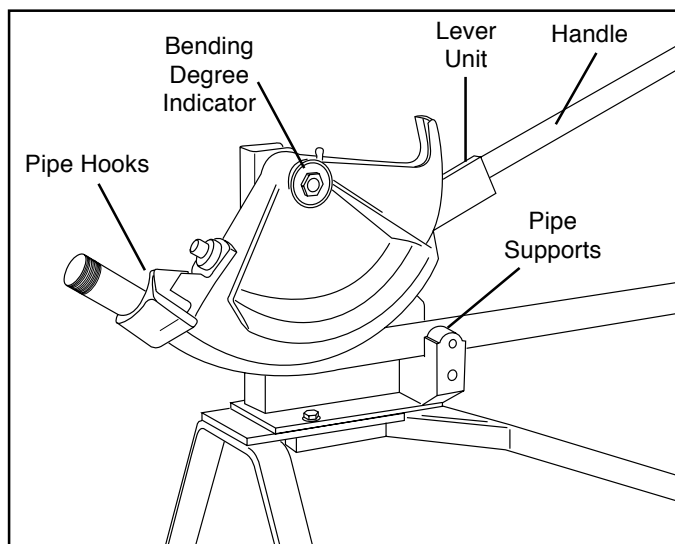
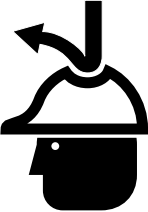

Figure 1

	⚠ WARNING
	<p>Do not leave the ratchet handle in the UP position when the bender is not in use. A handle left in the UP position could fall unexpectedly.</p>

⚠ CAUTION
<p>Remove the handle and conduit before moving the bender. Maintain a firm grip with both hands on the frame T-handle to prevent the bender from tipping over.</p> <p>Failure to observe this precaution may result in injury.</p>

Maintenance

Keep the bender clean and dry. Occasionally add oil at the two oil holes illustrated in the exploded view.

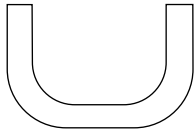
Illustrated Bending Glossary

1. **back-to-back bend** — any U-shaped bend formed by two parallel 90-degree bends with a straight section of conduit or pipe between the bends

2. **center-to-center distance** — the distance between the successive bends that make up an offset or a three-bend saddle

3. **developed length** — the actual length of pipe that will be bent; see distance “d” in the illustration

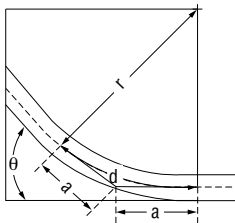

4. **gain** — the difference between the straight-line distance ($a + a$) and the shorter radial distance, (d) where:

θ = angle of bend

r = the centerline bending radius of the bending shoe

5. **kick** — single bend of less than 90°

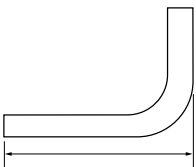

6. **leg length** — the distance from the end of a straight section of conduit or pipe to the bend; measured from the end to the outside edge of the conduit or pipe

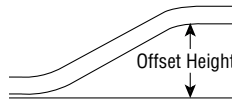

7. **offset bend** — two opposite bends with the same degree of bend; used to avoid an obstruction

8. **offset height** — the distance between the two legs of an offset bend, measured perpendicular to the two legs; also called amount of offset and depth of offset

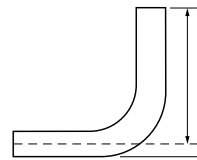

9. **rise** — the distance from the end of a straight section of conduit or pipe to the bend; measured from the end to the center line of the conduit or pipe. Also called stub or stub-up

10. **saddle** — a three-bend or four-bend combination; used to avoid an obstruction

11. **shrink** — the amount of conduit “lost” when laying out an offset bend working toward an obstruction

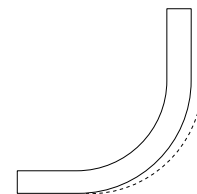

12. **springback** — the amount, measured in degrees, that a conduit or pipe tends to straighten after being bent

Bending Conduit

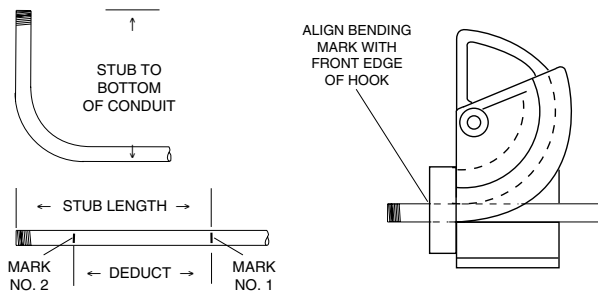

To Locate Bending Marks for Stubs

1. See the Stub Dimensions Table for the minimum stub length. The desired stub must be equal to or greater than the minimum stub length.
2. See the Stub Illustrations. Measure and mark the stub length on the conduit. This is mark 1. Subtract the deduct from the stub length and make mark 2. Mark 2 is the bending mark - locate this mark at the front edge of the hook.

Stub Dimensions Table

Conduit Size	Centerline Bending Radius	Minimum Stub Length	Deduct	Minimum Distance from End of Conduit
1-1/4"	8"	15-1/8	13-5/8	1-1/2
1-1/2"	9-5/8"	17-3/8	15-5/8	1-3/4

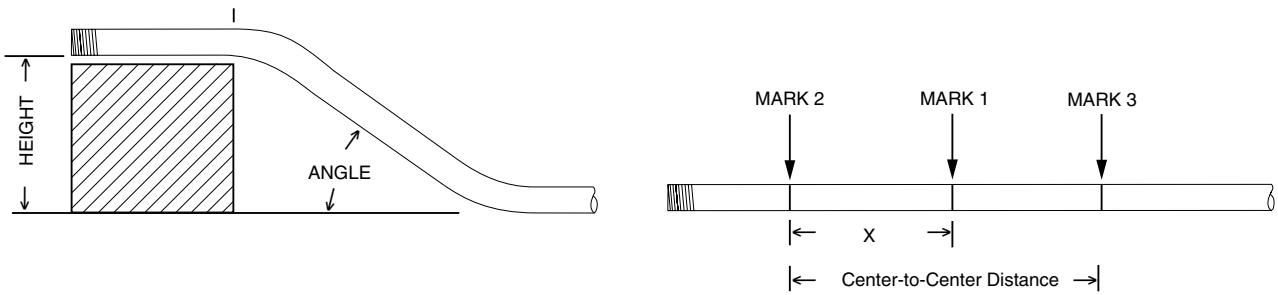
To Locate Bending Marks for Offsets

1. Measure the distance from conduit coupling to the edge of the obstruction and mark the conduit. This is mark 1.
2. See the Figure X Table. Subtract X inches from mark 1 and mark the conduit. This is mark 2.
3. Measure the height of the obstruction. This is the offset distance. Refer to the Offset Table to find the center-to-center distance at the intersection of the top row (offset distance) and the first column (offset angle). Measure and mark the center-to-center distance from mark 2. This is mark 3.
4. Insert the conduit into the bender with mark 2 aligned with the front edge of the hook. Make the first bend.
5. Without removing the conduit from the bender, rotate the conduit 180°. Align mark 3 with the front edge of the hook and make the second bend.

Figure X Table

Conduit Size	Figure X (Approximate)
1-1/4	4-1/2"
1-1/2	4-3/4"

Offset Dimensions Table

OFFSET DISTANCE ►		4	6	8	10	12	14	16	18	20	22
15°	Max Conduit Size	1-1/2									
	Center-to-Center	15-7/16	23-3/16	30-15/16	38-5/8	46-3/8	54-1/16	61-13/16	69-9/16	77-1/4	85
30°	Max Conduit Size	1-1/2									
	Center-to-Center			16	20	24	28	32	36	40	44
45°	Max Conduit Size	1-1/4									
	Center-to-Center				14-1/8	16-15/16	19-13/16	22-5/8	25-7/16	28-1/4	31-1/8

Figures are approximate

To calculate the center-to-center distance for any other offset bend, multiply:

(for 15° bends) Height of the Obstruction x 3.86

(for 30° bends) Height of the Obstruction x 2

(for 45° bends) Height of the Obstruction x 1.4

Special Bending Information

Laying Out Bends

The following illustrations and instructions show the most common bends. See the Special Bending Information Chart for precise bending dimensions.

Stubs

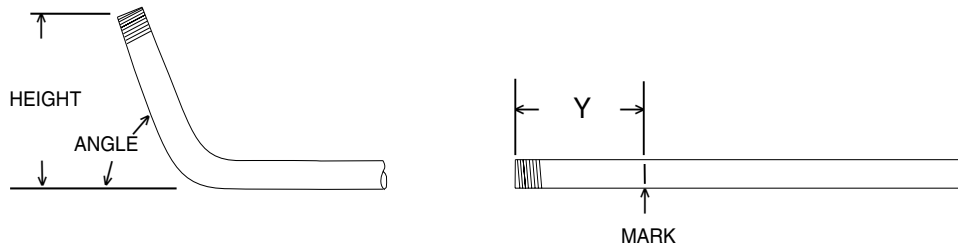

1. Select the size and type of conduit. Determine the height of stub and the angle of bend.
2. Find the chart that corresponds to the size of conduit selected in Step 1.
3. Under the column labeled ANGLE, find the angle of bend. Find the intersection of row Y and the appropriate column H. The number at this intersection is the dimension Y. Place the bending mark Y inches from the end of the conduit.
4. See the Operation section of this manual.

Offset

An offset is used to route the conduit around an obstruction. To make an offset, two equal bends are required. The distance between the two bends is the center-to-center distance. This is represented by L1 in the bending tables.

Offsets: Controlling the Start of the First Bend

(use this method when working past an obstruction)

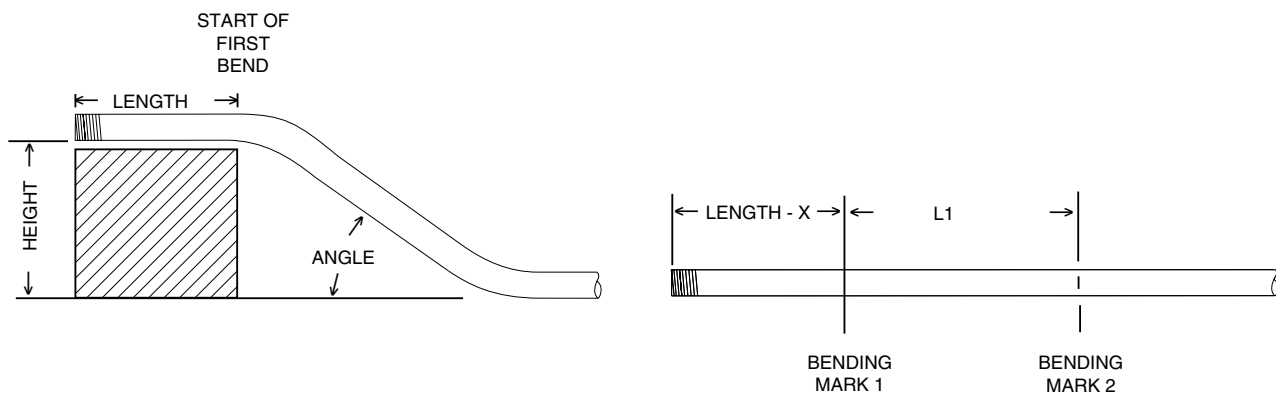

1. Select the size and type of conduit. Measure the height of the obstruction and the distance labeled LENGTH. Determine the angle to be used.
2. Find the chart that corresponds to the size of conduit selected in Step 1.
3. To the right of the size and type of conduit, find the dimension labeled X. Subtract X from LENGTH. Place the first bending mark this distance from the end of the conduit.
4. Under the column labeled ANGLE, find the angle of bend. Find the intersection of the L1 row and the appropriate HEIGHT column. The number at this intersection is the dimension L1. Place the second bending mark L1 inches from the first bending mark.
5. See the Operation section of this manual.

Special Bending Information (cont'd)

Offsets: Controlling the Start of the Second Bend

(use this method when working toward an obstruction)

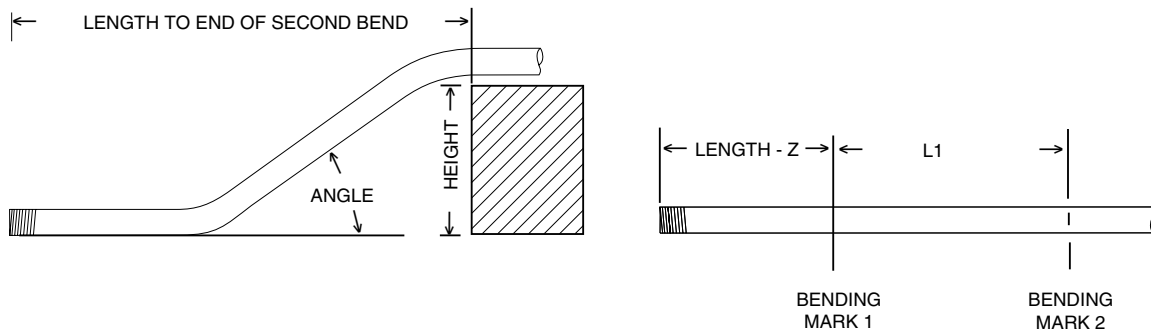

1. Select the size and type of conduit. Measure the height of the obstruction and the distance labeled LENGTH TO END OF SECOND BEND. Determine the angle to be used.
2. Find the chart that corresponds to the size of conduit selected in Step 1.
3. Under the column labeled ANGLE, find the angle of bend. Find the intersection of the Z row and the appropriate HEIGHT column. The number at this intersection is the dimension Z. Subtract Z from LENGTH TO THE END OF SECOND BEND. Place the first bending mark here.
4. In the same column, find the row labeled L1. Place the second bending mark L1 inches from the first bending mark.
5. See the Operation section of this manual.

Three-Bend Saddle

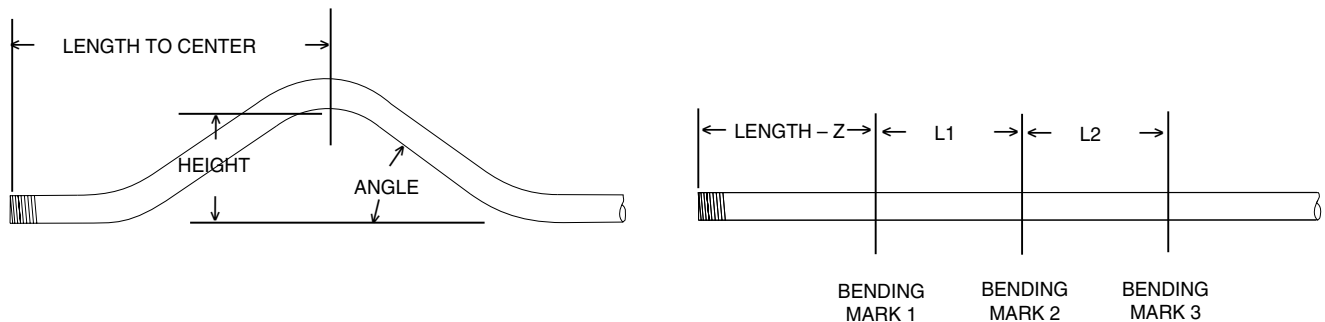

1. Select the size and type of conduit. Measure the height of the obstruction and the distance labeled LENGTH TO CENTER. Determine the angle to be used.
2. Find the chart that corresponds to the size of conduit selected in Step 1.
3. Under the column labeled ANGLE, find the angle of bend needed. Find the intersection of the Z row and the appropriate HEIGHT column. The number at this intersection is the dimension Z. Subtract Z from the LENGTH TO CENTER. Place the first bending mark here.
4. In the same column, find the row labeled L1. Place the second bending mark L1 inches from the first bending mark.
5. In the same column, find the row labeled L2. Place the third bending mark L2 inches from the second bending mark.
6. See the Operation section of this manual.

Note: The second bend angle will be twice the number of degrees as the first and third bends.

Special Bending Information (cont'd)

Four-Bend Saddle

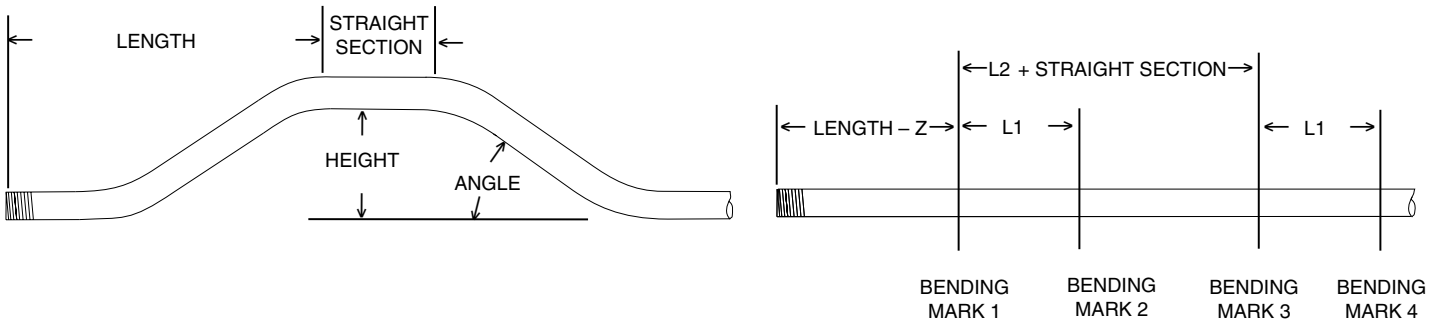

1. Select the size and type of conduit. Measure the height of the obstruction, the distance labeled **LENGTH**, and the distance labeled **STRAIGHT SECTION**. Determine the angle to be used.
2. Find the chart that corresponds to the size of conduit selected in Step 1.
3. Under the column labeled **ANGLE**, find the angle of bend needed. Find the intersection of the **Z** row and the appropriate **HEIGHT** column. The number at this intersection is **Z**. Subtract **Z** from the **LENGTH**. Place the first bending mark this distance from the end of the conduit.
4. In the same column, find the row labeled **L1**. Place the second bending mark **L1** inches from the first bending mark.
5. In the same column, find the row labeled **L2**. Add **L2** to the **STRAIGHT SECTION**. Place the third bending mark this distance from the first bending mark.
6. Make the final bending mark **L1** inches from the third bending mark.
7. See the Operation section of this manual.

U-Bends

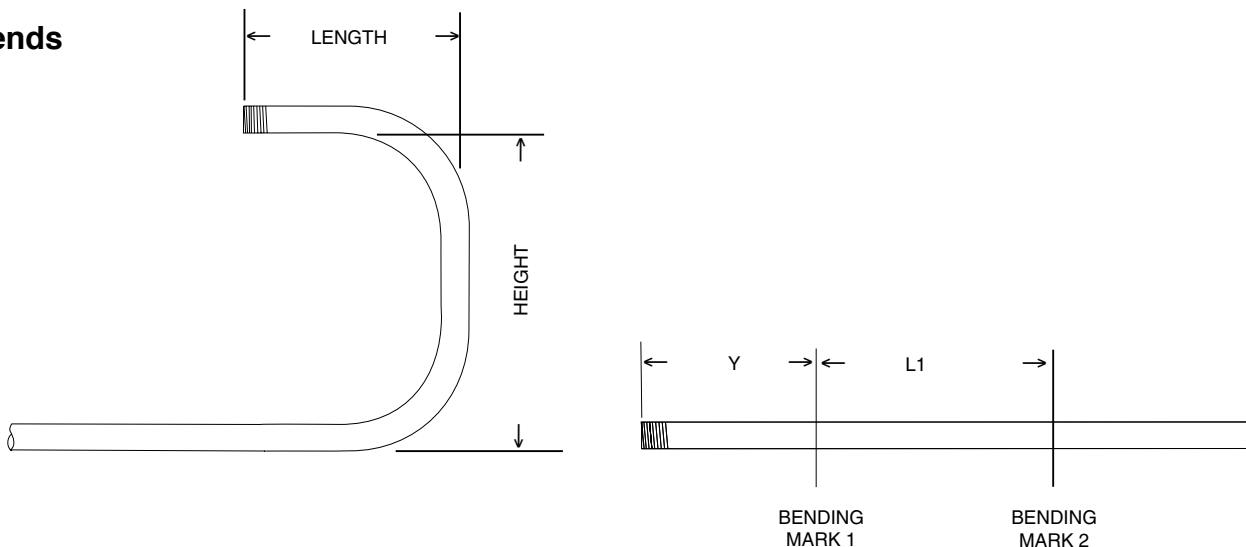

1. Select the size and type of conduit. Determine the **LENGTH** and the **HEIGHT**.
2. Find the chart that corresponds to the size of conduit selected in Step 1.
3. Under the column labeled **ANGLE**, find **90°**. Find the intersection of the **Y** row and the **HEIGHT** column that corresponds to the dimension labeled **LENGTH** in the illustration. Place the first bending mark **Y** inches from the end of the conduit.
4. Find intersection of the **L1** row and the **HEIGHT** column that corresponds to the dimension labeled **HEIGHT** in the illustration. Place the second bending mark **L1** inches from the first mark.
5. See the Operation section of this manual.

Special Bending Information Chart

		HEIGHT - H										
DIM	ANGLE	2"	4"	6"	8"	10"	12"	15"	18"	24"	36"	
1-1/4 IMC/RIGID		Dia. = 1.66		*Radius = 8.274		X = 4.52						
	Y	15.00		6.64	14.37	22.10	29.83	37.55	49.14	60.74	83.92	130.28
	L1	15.00	7.71	15.44	23.17	30.90	38.62	46.35	57.94	69.53	92.72	139.08
	L2	15.00	9.88	17.61	25.34	33.06	40.79	48.52	60.11	71.70	94.88	141.25
	Z	15.00	14.17	21.63	29.09	36.56	44.02	51.49	62.68	73.88	96.27	141.06
MINIMUM H = 1.73												
	Y	22.50		2.12	7.35	12.57	17.80	23.03	30.86	38.70	54.38	85.74
	L1	22.50		10.41	15.64	20.86	26.09	31.32	39.15	46.99	62.67	94.03
	L2	22.50		13.66	18.89	24.11	29.34	34.56	42.40	50.24	65.92	97.28
	Z	22.50		17.47	22.30	27.13	31.96	36.79	44.03	51.27	65.76	94.73
MINIMUM H = 2.99												
	Y	30.00			3.60	7.60	11.60	15.60	21.60	27.60	39.60	63.60
	L1	30.00			11.90	15.90	19.90	23.90	29.90	35.90	47.90	71.90
	L2	30.00			16.23	20.23	24.23	28.23	34.23	40.23	52.23	76.23
	Z	30.00			19.35	22.81	26.28	29.74	34.94	40.13	50.53	71.31
MINIMUM H = 4.48												
	Y	45.00				2.19	5.02	7.85	12.09	16.33	24.82	41.79
	L1	45.00					13.79	16.61	20.86	25.10	33.58	50.56
	L2	45.00					20.28	23.11	27.36	31.60	40.08	57.05
	Z	45.00					21.38	23.38	26.38	29.38	35.38	47.38
MINIMUM H = 8.05												
	Y	60.00					1.29	3.60	7.06	10.53	17.46	31.31
	L1	60.00							16.43	19.89	26.82	40.68
	L2	60.00							25.10	28.56	35.49	49.34
	Z	60.00							22.74	24.47	27.93	34.86
MINIMUM H = 12.19												
	Y	90.00							1.38	4.38	10.38	22.38
	L1	90.00									20.45	32.45
	L2	90.00									33.44	45.44
	Z	90.00									21.07	21.07
MINIMUM H = 21.07												
1-1/2 IMC/RIGID		Dia. = 1.90		*Radius = 9.965		X = 4.71						
	Y	15.00		5.76	13.49	21.22	28.94	36.67	48.26	59.85	83.04	129.40
	L1	15.00	7.71	15.44	23.17	30.89	38.62	46.35	57.94	69.53	92.71	139.08
	L2	15.00	10.32	18.05	25.78	33.50	41.23	48.96	60.55	72.14	95.32	141.69
	Z	15.00	14.80	22.26	29.73	37.19	44.65	52.12	63.31	74.51	96.90	141.69
MINIMUM H = 1.90												
	Y	22.50		1.28	6.50	11.73	16.96	22.18	30.02	37.86	53.54	84.90
	L1	22.50		10.40	15.63	20.85	26.08	31.31	39.15	46.99	62.66	94.02
	L2	22.50		14.31	19.54	24.77	29.99	35.22	43.06	50.90	66.58	97.93
	Z	22.50		18.33	23.16	27.99	32.82	37.64	44.89	52.13	66.62	95.59
MINIMUM H = 3.32												
	Y	30.00			2.72	6.72	10.72	14.72	20.72	26.72	38.72	62.72
	L1	30.00			11.88	15.88	19.88	23.88	29.88	35.88	47.88	71.88
	L2	30.00			17.09	21.09	24.09	29.09	35.09	41.09	53.09	77.09
	Z	30.00			20.44	23.91	27.37	30.83	36.03	41.23	51.62	72.40
MINIMUM H = 5.03												
	Y	45.00				1.13	3.96	6.79	11.03	15.27	23.76	40.73
	L1	45.00					13.71	16.54	20.78	25.03	33.51	50.48
	L2	45.00					21.54	24.37	28.61	32.85	41.34	58.31
	Z	45.00					22.97	24.97	27.97	30.97	36.97	48.97
MINIMUM H = 9.17												
	Y	60.00						2.30	5.76	9.22	16.15	30.01
	L1	60.00							16.25	19.71	26.64	40.50
	L2	60.00							26.68	30.15	37.08	50.93
	Z	60.00							24.88	26.61	30.07	37.00
MINIMUM H = 14.04												
	Y	90.00								2.38	8.38	20.38
	L1	90.00										31.72
	L2	90.00										47.38
	Z	90.00										24.64
MINIMUM H = 24.64												

*Note: Radius provided has been corrected to include 3% springback.

Exploded View

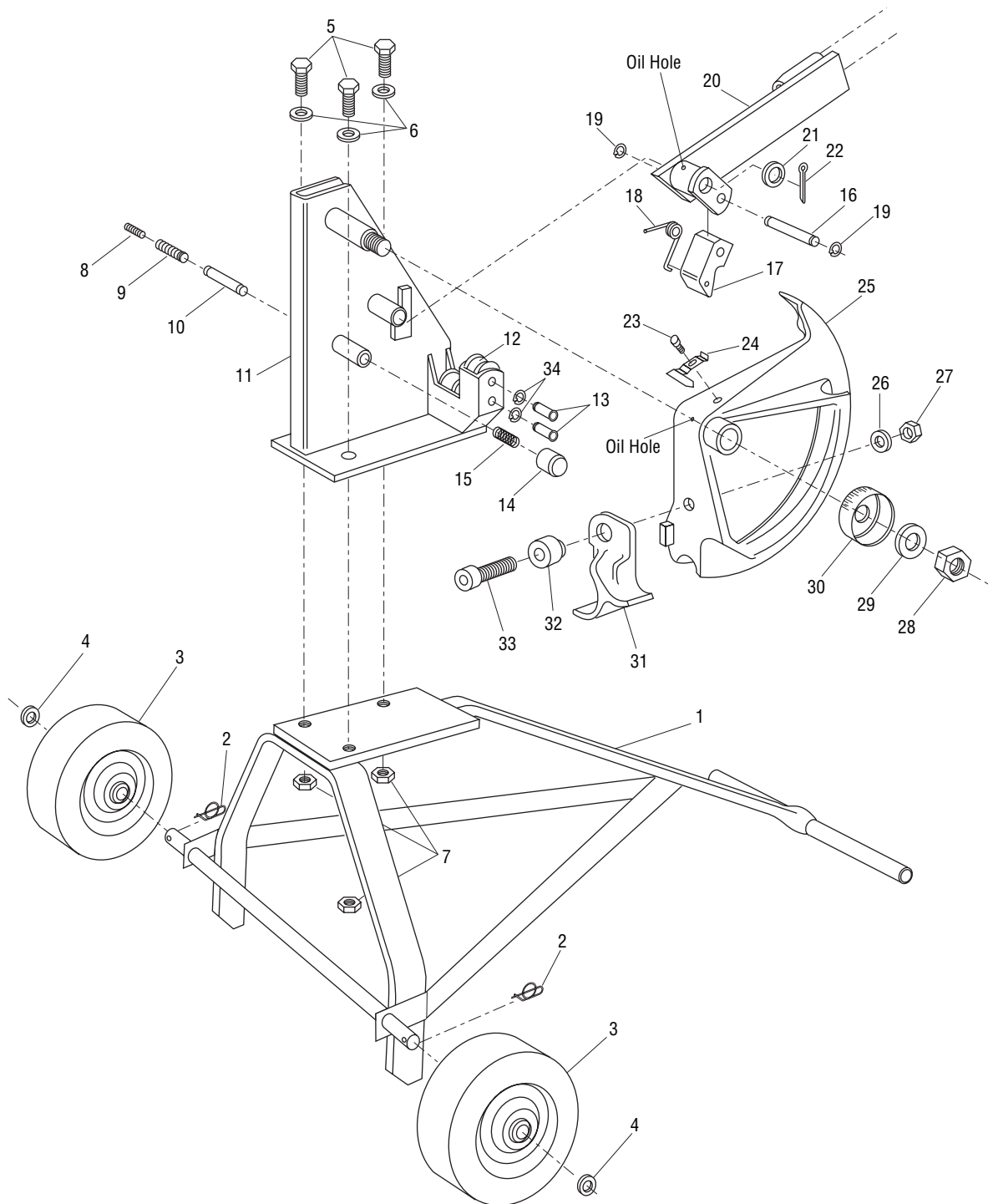

Parts List - 1801 Ratchet Bender with "RS" serial code

Key	Part No.	Description	Qty.
	50247530	1801 Ratchet Bender: consists of 1 - 34	
	50245074	1801G1 Ratchet Bender Head: consists of 8 - 34	
1	50084291	Carriage Unit (includes 2 - 4).....	1
2	90552989	Ring, Rue, 3/4 reg.....	2
3	52023602	Wheel, no-flat (benders with Serial No. RS15000 and up)	2
	90515099	Wheel, 8" O.D., (benders with Serial No. preceding RS15000)	2
4	90517407	Washer, flat	2
5	90505441	Screw, cap, 1/2 - 13 x 1.500" hex head.....	3
6	90505417	Washer, lock, .516 x .871 x .099"	3
7	90527941	Nut, hex, 1/2 - 13 zinc-plated.....	3
	50245074	Bending Head Unit (includes 8 - 34)	1
8	90514866	Screw, jam, 1/2 - 13 x .250" socket	1
9	90526090	Screw, set, 1/2 - 13 x 1.00" socket flat point	1
10	50247255	Spacer	1
11	50245082	Frame unit, bending head	1
12	50249231	Roller, pipe support.....	2
13	50009257	Axle, .500 x 2.00"	2
14	50247514	Button, tension	1
15	50133373	Spring, compression, .352 x .648 x 1.75"	1
	50295055	Ratchet Lever Unit (includes 16 - 20).....	1
16	50244892	Pin, pawl pivot, .499 x 1.87"	1
17	50295047	Ratchet pawl	1
18	50244914	Spring, torsion.....	1
19	90513797	Ring, retaining	2
20	50244825	Lever unit	1
21	90525701	Washer, flat, 1.00 x 1.50 x .075"	1
22	90506561	Pin, cotter, .125 x 1.50"	1
23	90515021	Screw, thumb, 1/4 - 20 x .500"	1
24	50245228	Pointer, adjustable	1
25	50245309	Shoe	1
26	90549830	Washer, flat, .625 x 1.25 x .093"	1
27	90524020	Nut, 5/8 - 11	1
28	90506944	Nut, 7/8 - 14 light jam.....	1
29	90513061	Washer, lock, .901 x 1.46 x .219"	1
30	50245236	Degree indicator unit.....	1
31	50245252	Hook	1
32	50179748	Pivot	1
33	90511166	Screw, cap, 5/8 - 11 x 2.50" socket head	1
34	90513533	Ring, retainer	2
Decals (not shown):			
	50121219	Decal, Greenlee safety	1
	50198203	Decal, Instruction	1
	50280872	Decal, Bending information	1



GREENLEE®

A Textron Company

USA	800-435-0786	Fax: 800-451-2632
	815-397-7070	Fax: 815-397-1865
Canada	800-435-0786	Fax: 800-524-2853
International	+1-815-397-7070	Fax: +1-815-397-9247

4455 Boeing Drive • Rockford, IL 61109-2988 • USA • 815-397-7070
An ISO 9001 Company • Greenlee Textron Inc. is a subsidiary of Textron Inc.

www.greenlee.com

Printed in USA