

16602-T



Call Us First!

DO NOT RETURN TO STORE.

For immediate help with assembly or product information
call our toll-free number:

1-888-827-9056

or email:

customerservice@backyardproductsllc.com

Our staff is ready to provide assistance.

April through October M - F 8:00 AM to 7:00 PM EST

Saturday 8:30 AM to 4:30 PM EST

November through March M - F 8:00 AM to 5:00 PM EST

ANTES DE DEVOLVERLO, ¡LLÁMENOS!

Si desea más información sobre el montaje, llámenos sin coste
adicional alguno al siguiente teléfono:

+1-888-827-9056

o correo electrónico:

customerservice@backyardproductsllc.com

Nuestro personal le proporcionará toda la ayuda que necesite.

Abril por octubre M - F 8:00 EST a 7:00 P.M. EST

el sábado 8:30 EST a 4:30 P.M. EST

noviembre por marzo M - F 8:00 EST a 5:00 P.M. EST

(This page intentionally left blank.)

(Esta página está intencionado en blanco.)

Customer Service
(Servicio al cliente)
1-888-827-9056
1000 Ternes Drive
Monroe, MI 48162

Premier / Heritage Series

10' Wide Gambrel

Cubierta a la holandesa de 10'

Includes 10'x8' (305x244 cm), 10'x12' (305x366 cm),
10'x16' (305x488 cm) Building Instructions

Instrucciones para edificios de 10'x8' (305x244 cm),
10'x12' (305x366 cm), 10'x16' (305x488 cm)

Tools required (Herramientas necesarias)

- Hammer
(Martillo)
- Phillips Screw-
driver
(Desarmador cruz)
- Level
(Nivel)
- Ladder
(Escalera)
- Pencil
(Lápiz)
- Tape Measure
(Cinta métrica)
- Utility Knife
(Navaja)
- Paint Tools
(Herramientas
para pintar)
- Caulk Gun
(Pistola para masil-
lado)
- Hand Saw
(Sierra portátil)
- Wood Glue
(Pegamento para
madera)

Optional Tools (Herramientas opcionales)

- Electric Drill w/ #2
Phillips Tip
(Taladro eléctrico
Broca "Phillips")
- Chalk Line
(Línea de marcar)
- Square
(Escuadra)
- Nail Pouch
(Bolsillo para
clavos)

- BEFORE YOU BEGIN -

First...

- Check with your local building authority before erecting.
- Read instructions thoroughly before you begin.

Building Codes

- Our buildings are designed to meet most local and national U.S. codes and are not meant to be used for living space.
- General construction drawings can be provided.
- Stamped certified drawings can be provided for a fee. Call for details.

Check All Parts

- If a part is missing, circle the part in question and call.
- Please note the primer color may vary on siding and trim parts. This is a factory applied primer intended for preparing your building for painting. This is NOT a finish coat. This primer color variation will not affect the look of your building once painted.

Important

- Lumber is graded from one side, use most attractive face to the outside.
- In a drawing, a dotted line represents a part hidden from view (like a part under a panel).

Assistance required

- Assistance is necessary to handle, fit, and secure some components.

Squareness is very Important!

- Keep 90° corners and 90° perpendiculars throughout the assembly to ensure all components fit together.

Check foundation size

- Before starting on your foundation, make sure you are building the correct size foundation for your building.

Always wear OSHA-APPROVED safety glasses throughout assembly process.

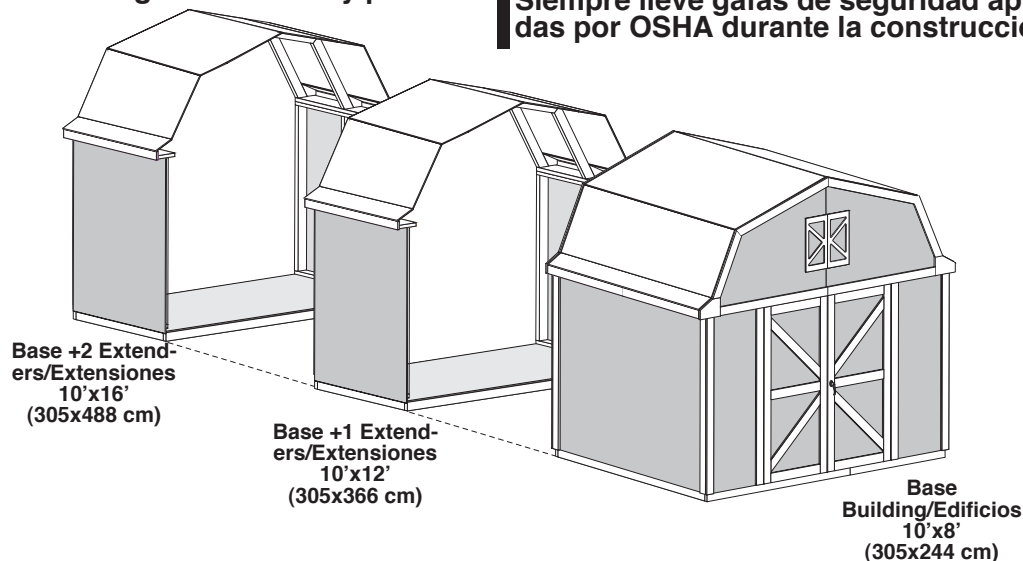

- ANTES DE EMPEZAR -

Primero...

- Consulte la autoridad de construcción local antes de construir el edificio.
- Lea las instrucciones completamente antes de empezar.

Códigos de Construcción

- Hemos diseñado nuestros edificios a que conformen con todos los códigos de construcción locales y nacionales. Los edificios no están proyectados como residencia.
- Se disponen planes generales de construcción.
- Se disponen de planes certificados por un precio. Estos planes no garantizan la aprobación de las autoridades locales.

Compruebe todas las piezas

- Si falta una pieza, indícala con un círculo y llámenos.
- Aviso: El color del imprimador puede variar en la cobertura y las partes de la moldura. Este imprimador se aplica en la fábrica y es para preparar su edificio para pintar. NO es una capa de pintura terminada. La variación en el color del imprimador no afectará la apariencia de su edificio al pintarlo.

Importante

- La Madera está elaborada en un solo lado. Use el lado más atractivo en el exterior.
- Si falta una pieza, póngale un círculo y llámenos.
- En un dibujo una línea punteada representa una pieza no vista (por ejemplo, una pieza debajo de un panel)

Ayuda requerido

- Seleccione un sitio nivelado.
- Será necesario pedir ayuda para manejar, unir, y reforzar algunas piezas.

¡Es preciso escuadrar el edificio!

- Mantenga ángulos de 90° en las esquinas y los perpendiculares durante la construcción para asegurar que todas las piezas se unen correctamente.

Compruebe las dimensiones de la cimentación.

- Compruebe que las dimensiones de la cimentación son las correctas para el edificio.









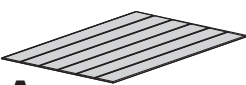
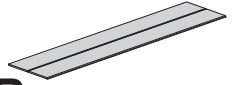
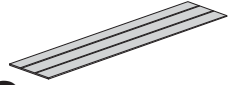
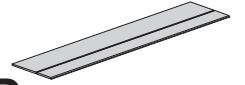
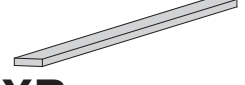

Siempre lleve gafas de seguridad aprobadas por OSHA durante la construcción.



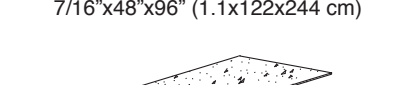
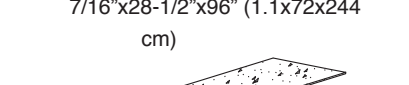
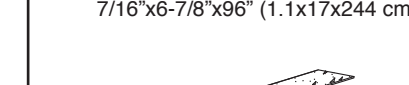

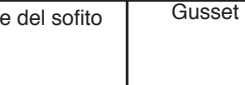
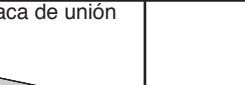
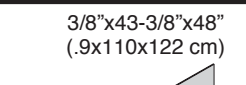
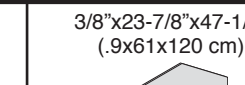
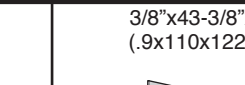
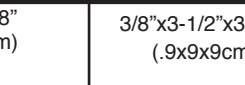
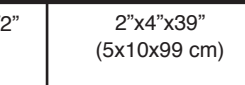
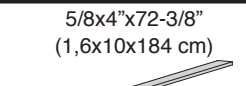
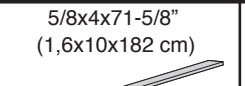

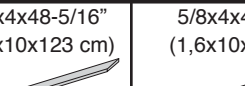
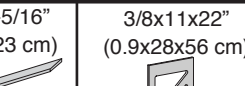
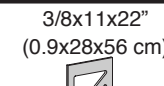
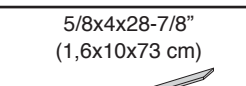
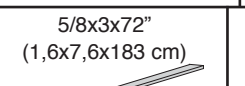
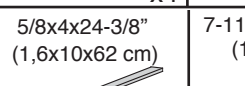
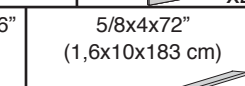

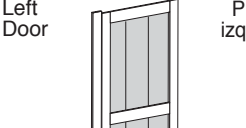
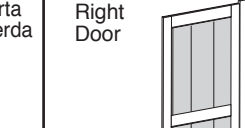
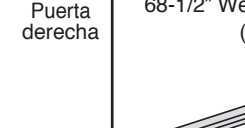
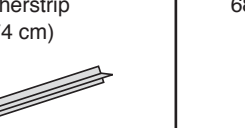
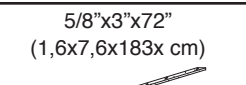
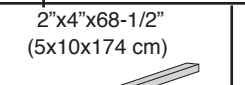
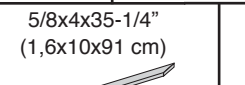
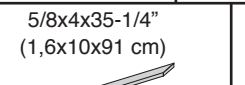
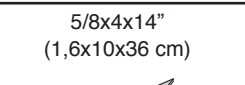

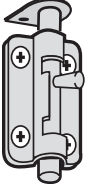

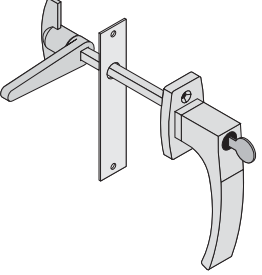

We manufacture kits from select construction grade lumber and engineered wood products. Construction grade lumber, a product cut from trees, has many natural characteristics and blemishes that may be present in some of the pieces you receive in your kit. Natural characteristics and blemishes in construction lumber may include knots, torn wood grain along edges, minor cracks/splits, twists, limited bark along edges and pitch pockets that may exude sap. Be assured that the individual parts have been cut and inspected to remove as many of the wood's natural, less appealing characteristics as possible. These characteristics and/or blemishes will not affect the strength, durability, or structural integrity of the finished product. Generally, the exterior trim parts selected for your kit are graded from only one side and should be installed with the most attractive side outward. Our limited warranty does not cover the natural characteristics and blemishes that occur with construction grade lumber products.

Fabricamos nuestros equipos de madera elaborada y de productos maquinados de madera. La madera elaborada, producto de árboles, tiene muchas características e imperfecciones naturales que puedan tener algunas piezas contenidas en el equipo. Estas imperfecciones y características pueden incluir nudos, grano rasgado sobre el borde, rajagrietas pequeñas, torsiones, cortezas en el borde, y bolsos que exuden savia. Aseguramos que hemos cortado e inspeccionado las partes individuales para eliminar las características naturales menos atractivas posibles. Estas características y/o imperfecciones no afectarán la fuerza, durabilidad ni la integridad estructural del producto final. Por lo general, las piezas de moldura exterior seleccionadas para su equipo se elaboran de un solo lado y deben ser instaladas con la parte más atractiva por fuera. Nuestra garantía limitada no cubre las características e imperfecciones que ocurren con los productos de madera elaborada.



**10' X 8' (305 x 244 cm)
PARTS LIST**



**10' X 8' (305 x 244 cm)
LISTA DE PIEZAS**

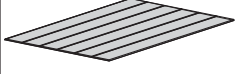
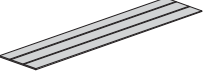
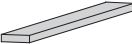
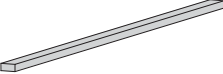
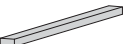

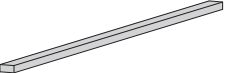

MURO	A 3/8"x48"x72" (.9x122x183 cm)  x6	B 3/8"x15-7/8"x72" (.9x40x183 cm)  x2	C 3/8"x23-7/8"x72" (.9x61x183 cm)  x1	D 3/8"x11-7/8"x72" (.9x30x183 cm)  x2	XB 2x8x92-1/2" (235 cm)  x2
	TP 2x4x96" (244 cm)  x2	TJ 2x4x92-1/2" (235 cm)  x8	UM 2x4x68" (173 cm)  x22	RL 2x4x24" (61 cm)  x6	
WALLS	F 7/16"x48"x96" (1.1x122x244 cm)  x2		G 7/16"x28-1/2"x96" (1.1x72x244 cm)  x2		H 7/16"x6-7/8"x96" (1.1x17x244 cm)  x2
	N Rafters  x10	P Viga Soffit Block Bloque del soffito  x10	Q Gusset Placa de unión  x8	TP 2x4x96" (244 cm)  x3	
TECHO	R 3/8"x43-3/8"x48" (.9x110x122 cm)  x2	Y 3/8"x23-7/8"x47-1/8" (.9x61x120 cm)  x2	S 3/8"x43-3/8"x48" (.9x110x122 cm)  x2	Z 3/8"x3-1/2"x3-1/2" (.9x9x9 cm)  x4	QL 2"x4"x39" (5x10x99 cm)  x4
	ROOF				
GABLE	ZP 5/8x4"x72-3/8" (1,6x10x184 cm)  x2	ZK 5/8x4x71-5/8" (1,6x10x182 cm)  x4	YZ 5/8x4x54-9/16" (1,6x10x139 cm)  x4	ZQL 5/8x4x48-5/16" (1,6x10x123 cm)  x2	ZQR 5/8x4x48-5/16" (1,6x10x123 cm)  x2
	TRIM	U 3/8x11x22" (0.9x28x56 cm)  x2	YV 5/8x4x28-7/8" (1,6x10x73 cm)  x4	ZJ 5/8x3x72" (1,6x7,6x183 cm)  x4	ZZ 5/8x4x24-3/8" (1,6x10x62 cm)  x2
MOLDURA	TR 7-11/16x10-1/16" (19x26 cm)  x2	ZO 5/8x4x72" (1,6x10x183 cm)  x1			
	DOOR	V Left Door  x1	W Puerta izquierda Right Door Puerta derecha  x1	DWS 68-1/2" Weatherstrip (174 cm)  x1	DEL 68-1/2" Metal Door Edge "L" (174 cm)  x2
PUERTA	X 5/8"x3"x72" (1,6x7,6x183 cm)  x1	UP 2"x4"x68-1/2" (5x10x174 cm)  x2	ZWL 5/8x4x35-1/4" (1,6x10x91 cm)  x2	ZWR 5/8x4x35-1/4" (1,6x10x91 cm)  x2	HU 5/8x4x14" (1,6x10x36 cm)  x4

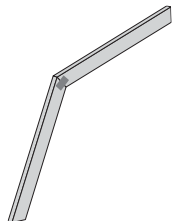
10' X 8' (305 x 244 cm) PARTS LIST		10' X 8' (305 x 244 cm) LISTA DE PIEZAS			
FERRERIA HARDWARE			Actual Size	Dimensiones verdaderas	
			3" (7.6 cm)		x262
			2" (5.0 cm)		x639
			2" (5.0 cm)		x230
			1-1/2" (3.8 cm)		x188
			3" (7.6 cm) ⊕		x18
			2" (4.1 cm) ⊕		x12
			1-5/8" (4.1 cm) ⊕		x10
			1" (2.5 cm) ⊕		x59
	1" (2.5cm)		x2	1" (2.5 cm) ⊕	
1-1/4" (3cm)		x2	3/4" (1.9 cm) ⊕		x24

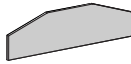
10' X 4' (305 x 122 cm) EXTENDER PARTS LIST			10' X 4' (305 x 122 cm) LISTA DE PIEZAS DE EXTENSIÓN		
					
A	C	XE	UM	SP	

			
J	K	L	TP

			
ZT	N	P	Q

Actual Size		Dimensiones verdaderas	
	x 72		x 198
3" (7.6 cm)		2" (5.0 cm)	
	x 4		x 12
3" (7.6 cm)		2" (5.0 cm)	
			x 48
		1-1/2" (3.8 cm)	

IMPORTANT!!!

Building Tip

FOR THE BEST LOOKING FINISHED PRODUCT WE RECOMMEND THAT YOU INSPECT, SORT AND LAY OUT MATERIALS PRIOR TO BEGINNING ASSEMBLY OF YOUR BUILDING

IMPORTANTE!!!

Consejo

CON EL FIN DE OBTENER EL PRODUCTO ACABADO DE MEJOR ASPECTO RECOMENDAMOS QUE INSPECCIONE, CLASIFIQUE Y ORGANICE LOS MATERIALES ANTES DE EMPEZAR A MONTAR SU EDIFICIO

HELPFUL MATERIAL NOTICE

AVISO ÚTIL SOBRE LOS MATERIALES

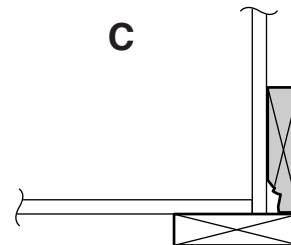
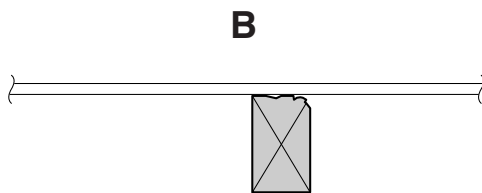
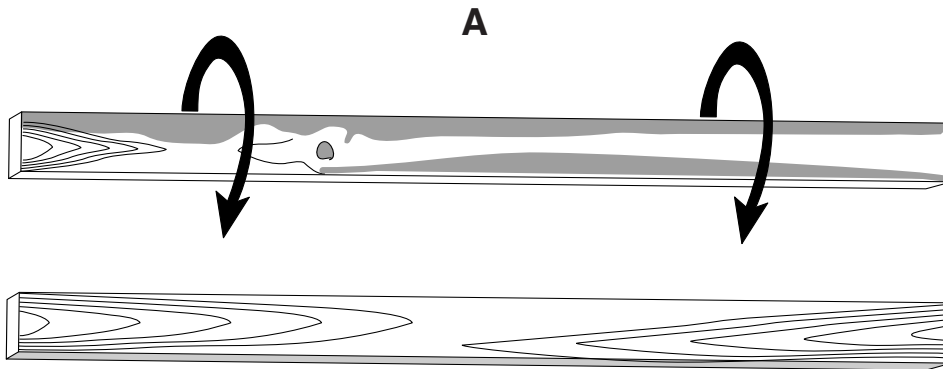

Wood is a natural product that has inherent blemishes. All interior framing is graded for structural strength and not appearance. Exterior trim is graded for one good side per industry standards.

- Blemishes can be easily installed to provide the best appearance. (Fig. A)
- Install wall framing with any blemished sides toward the siding and facing rear of building. (Fig. B)
- Install corner trim, gable trim and fascia with any blemished sides toward the siding material. (Fig. C)

Always install the material leaving the best edge and best surface visible.

Please remember that these blemishes in no way negatively affect the strength or integrity of our product.

La madera es un producto natural que tiene defectos inherentes. Todo la estructura interior ha sido aprobada por ofrecer una resistencia estructural y no por su aspecto. La guarnición exterior ha sido aprobada por tener un buen lado según las normas de la industria.

- La parte con defectos puede instalarse fácilmente de modo que el edificio tenga el mejor aspecto. (Fig. A)
- Instale el entramado de la pared con los lados con defectos apuntando hacia los costados y haciendo frente a la parte trasera del edificio. (Fig. B)
- Instale la guarnición de las esquinas, la guarnición de los hastiales y las impostas con los lados con defectos apuntando hacia el material lateral. (Fig. C)

Instale siempre el material dejando visibles el mejor borde y la mejor superficie.

Recuerde que estos defectos no afectan de forma negativa la resistencia o la integridad de nuestros productos.

Please feel free to call our Consumer Help Line - Toll Free
1-888-827-9056

April through October M - F 8:00 AM to 7:00 PM EST

Saturday 8:30 AM to 4:30 PM EST

November through March M - F 8:00 AM to 5:00 PM EST

Llame de forma gratuita a nuestra línea de ayuda al
consumidor

1-888-827-9056

Abril por octubre M - F 8:00 EST a 7:00 P.M. EST

el sábado 8:30 EST a 4:30 P.M. EST

noviembre por marzo M - F 8:00 EST a 5:00 P.M. EST

FOUNDATION OPTIONS

(Not supplied with kit)

YOU MUST ASSEMBLE YOUR BUILDING ON A WOOD FLOOR OR CONCRETE SLAB.

OPCIONES PARA LA CIMENTACIÓN

(No incluidas)

HAY QUE CONSTRUIR EL EDIFICIO SOBRE UN BASE DE MADERA O DE CONCRETO.

SITE PREPARATION

- Site must be properly leveled.
- Site should have natural drainage and no standing water

PREPARACIÓN DEL SITIO

- El sitio debe de estar nivelado correctamente.
- Instale una barrera contra yerbajos debajo de la estructura.

A) Purchase our optional Floor Kit or build your own wood floor.

A) Compre nuestro equipo opcional para el suelo o construya su propio suelo de madera.

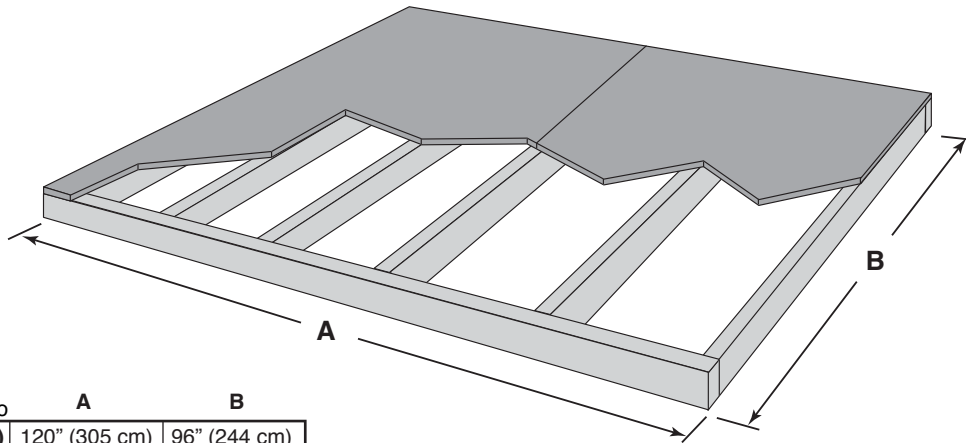

Building Size Dimensiones del edificio	A	B
10' x 8' (305 x 244 cm)	120" (305 cm)	96" (244 cm)
10' x 12' (305 x 366 cm)	120" (305 cm)	144" (366 cm)
10' x 16' (305 x 488 cm)	120" (305 cm)	192" (488 cm)

Important: Square floor and level to ground before beginning assembly of building.

Importante: Asegure que el suelo está nivelado y escuadrado antes de construir el edificio.

B) Concrete Slab Foundation

B) Base en losa de concreto

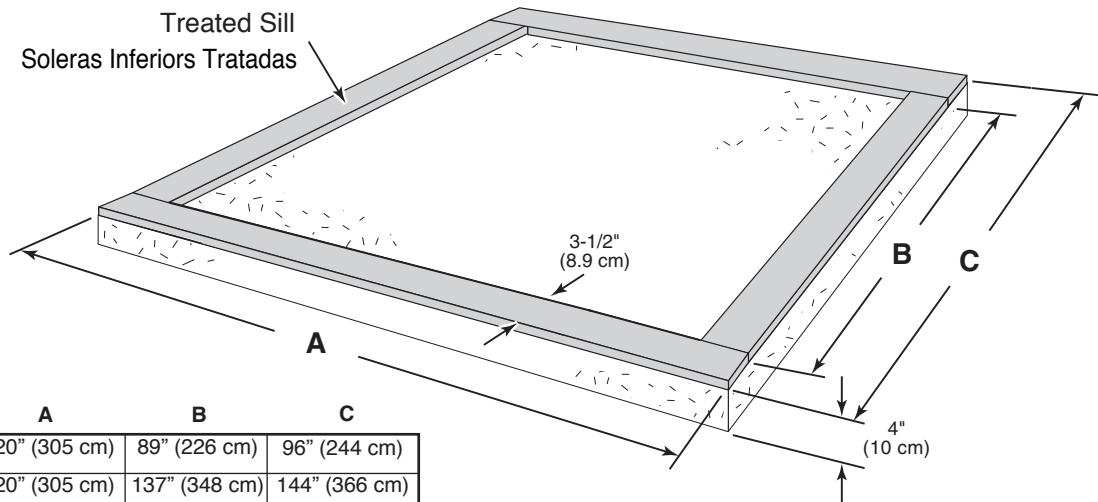

Building Size Dimensiones del edificio	A	B	C
10' x 8' (305 x 244 cm)	120" (305 cm)	89" (226 cm)	96" (244 cm)
10' x 12' (305 x 366 cm)	120" (305 cm)	137" (348 cm)	144" (366 cm)
10' x 16' (305 x 488 cm)	120" (305 cm)	185" (470 cm)	192" (488 cm)

Fasten treated 2x4 sill plates to slab using approved concrete anchors. (Treated sill plates and fasteners not included.)

Fije las soleras inferiores tratadas 2x4 a la losa con anclajes de concreto aprobados. (Las soleras y los anclajes no están incluidos.)



Before proceeding, determine desired door location and build door wall first.



Antes de continuar determine la posición de la puerta y construya el muro con la puerta primero.

BUILD WALL NUMBERS SPECIFIED

WALL NUMBER EQUALS PAGE NUMBER

CONSTRUYA LOS NÚMEROS DE LOS MUROS ESPECIFICADOS

EL NÚMERO DEL MURO CORRESPONDE AL NÚMERO DE LA PÁGINA.

10' X 8' (244x244 cm)

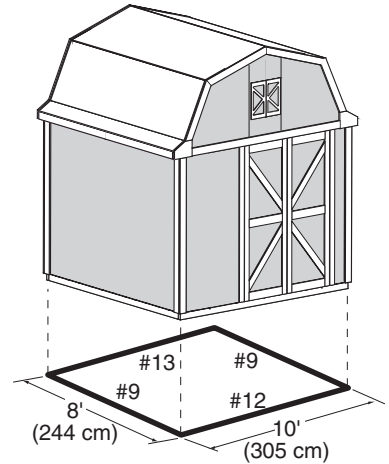
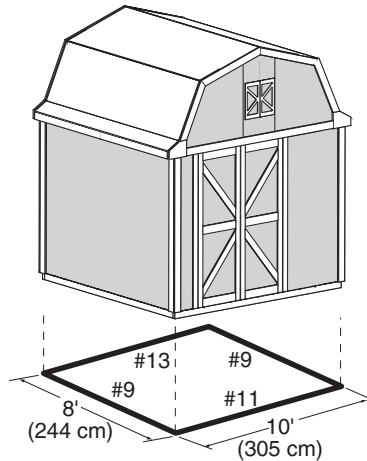
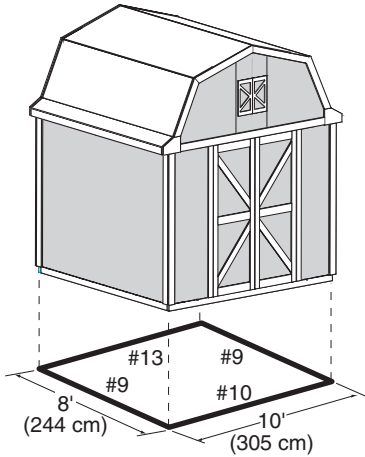

10' X 12' (305x366 cm)

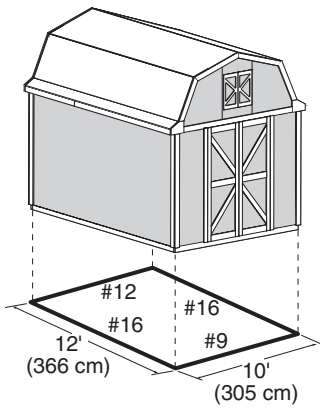

To Offset Door to Right See Wall #12
Compensar Puerta a Derecho véase la Muro #12

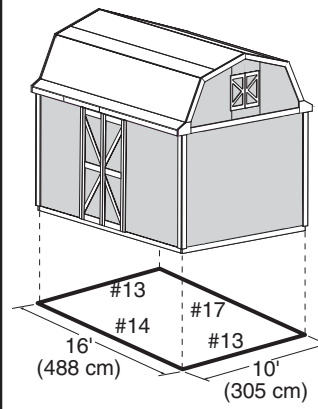
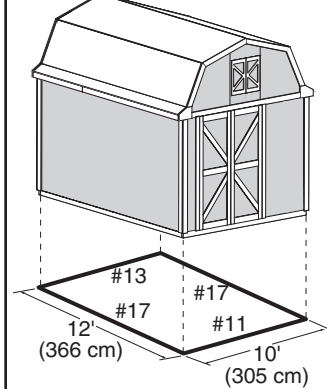

To Offset Door to Right See Wall #16
Compensar Puerta a Derecho véase la Muro #16

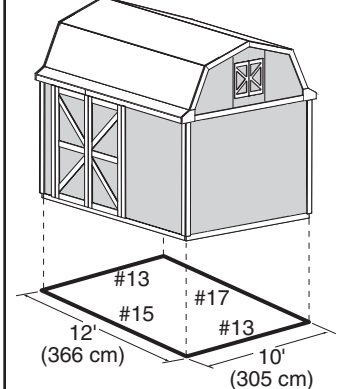

10' X 16' (305x488 cm)

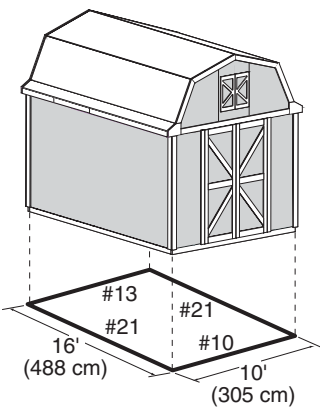

To Offset Door to Right See Wall #12
Compensar Puerta a Derecho véase la Muro #12

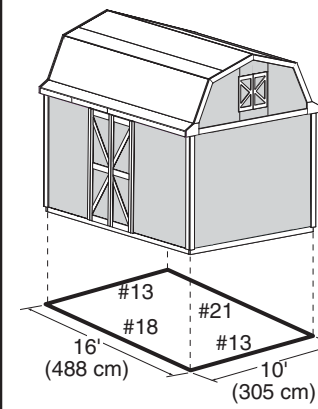
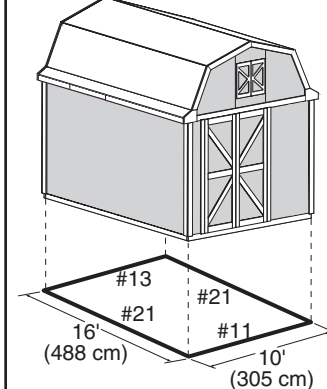

To Offset Door to Right See Wall #20
Compensar Puerta a Derecho véase la Muro #20

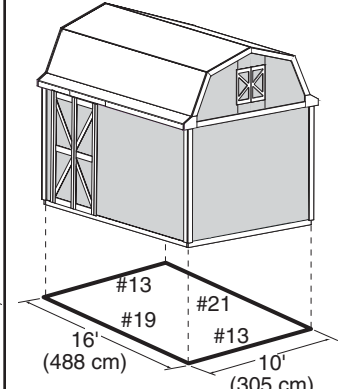

IMPORTANT!!!

Building Tip

YOUR BUILDING CAN BE CONFIGURED IN A VARIETY OF WAYS. BEFORE ERECTING WALLS, REFER TO PAGE 5 TO ENSURE YOU BUILT THE RIGHT WALLS FOR YOUR BUILDING.

IMPORTANTE!!!

Consejo

ES PRECISO ALINEAR LOS PANELES DE LOS MUR-OS Y DEL TECHO ANTES DE CLAVARLOS COMPLETAMENTE PARA ASEGURAR LA ESCUADRA.

Erecting the Walls

Make sure all walls are built as shown below.
BUILD DOOR WALL FIRST.

Construyendo los Muros

Asegure que se construyan los muros como en los dibujos abajo
CONSTRUYA EL MURO CON PUERTA PRIMERO

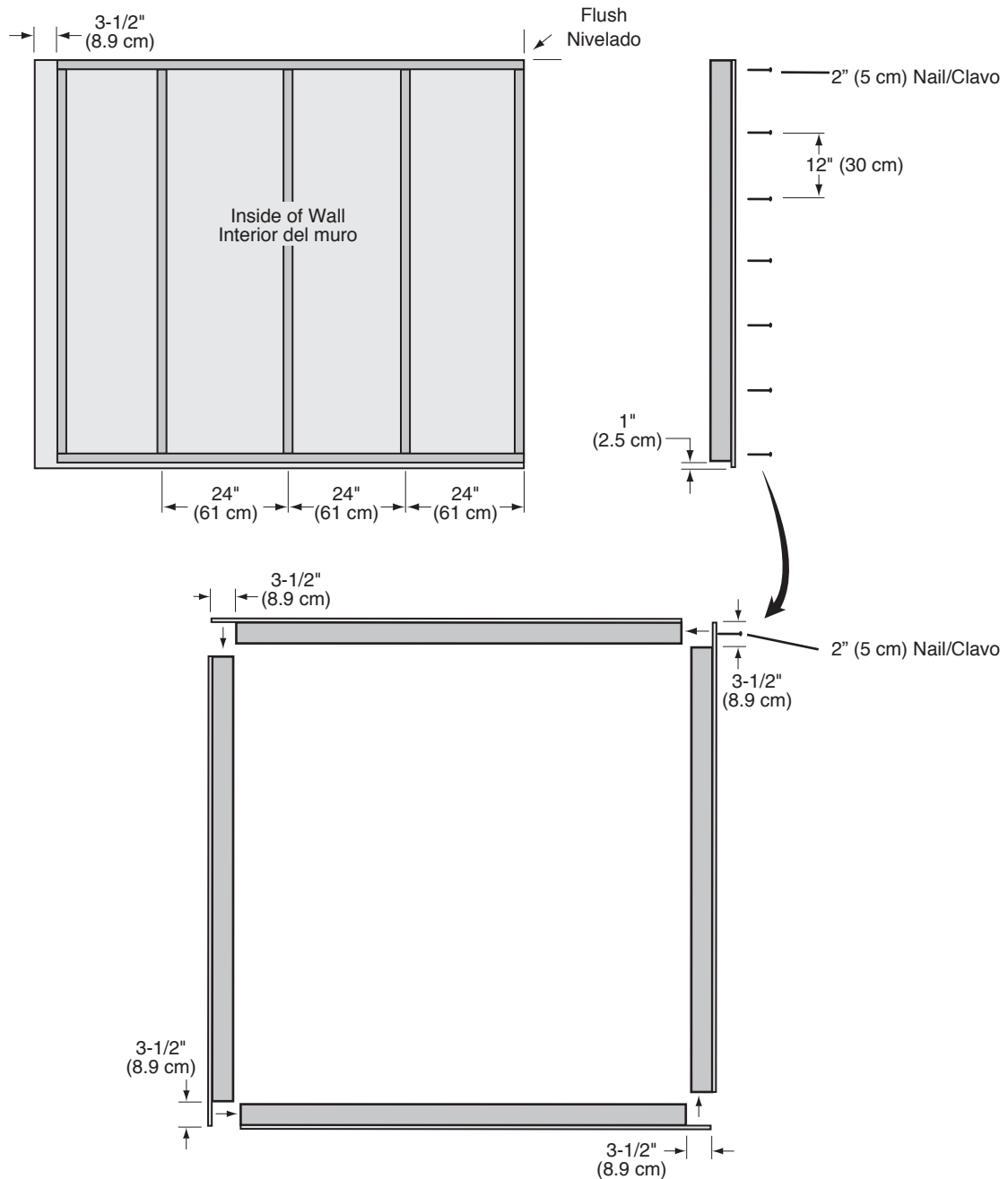

IMPORTANT!!!

Building Tip

YOU MAY NEED TO RACK YOUR WALL PANELS AND ROOF PANELS TO ENSURE SQUARENESS BEFORE COMPLETELY NAILING

IMPORTANTE!!!

Consejo

ES PRECISO ALINEAR LOS PANELES DE LOS MUR-OS Y DEL TECHO ANTES DE CLAVARLOS COMPLETAMENTE PARA ASEGURAR LA ESCUADRA.

Racking a Wall

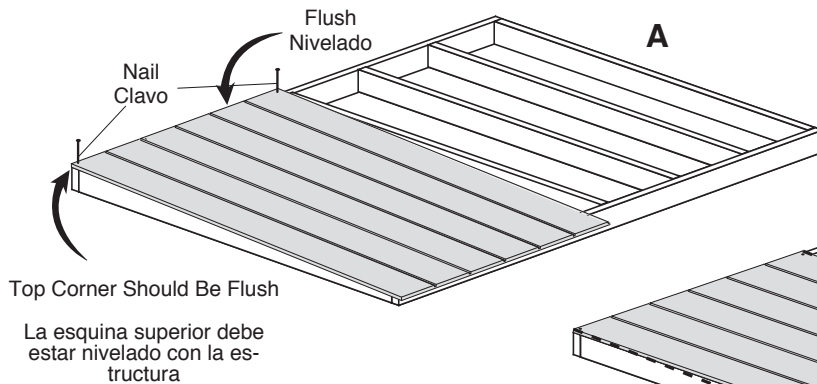

Alineando un Muro

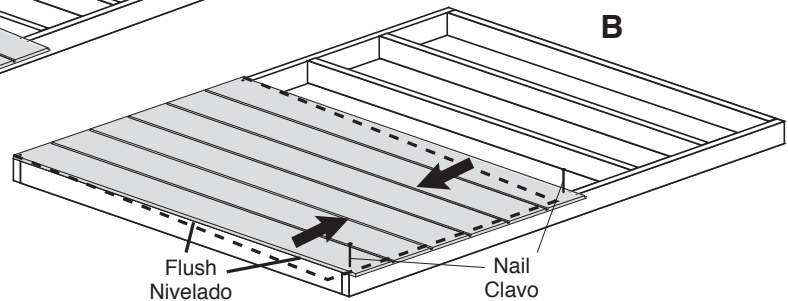

When building walls, always apply panel at far left first. Position panel flush with top of wall frame and nail in upper corners as shown. Rack wall square by moving lower end of wall panel right or left until panel is flush with framing along left edge and secure with one nail in each lower corner. Continue nailing as instructed.

Al construir los muros, siempre fije primero el panel hasta la izquierda extrema. Posicione el panel nivelado con la parte superior de la estructura del muro y clávelo en la esquina superior como en el dibujo. Alinee nivelado el muro por mover el lado inferior a la derecha o a la izquierda hasta que el panel esté nivelado con la estructura a lo largo del borde izquierda. Fije con un clavo en cada esquina inferior.

Racking a Roof

Rack for Squareness
Nivele para escuadrar

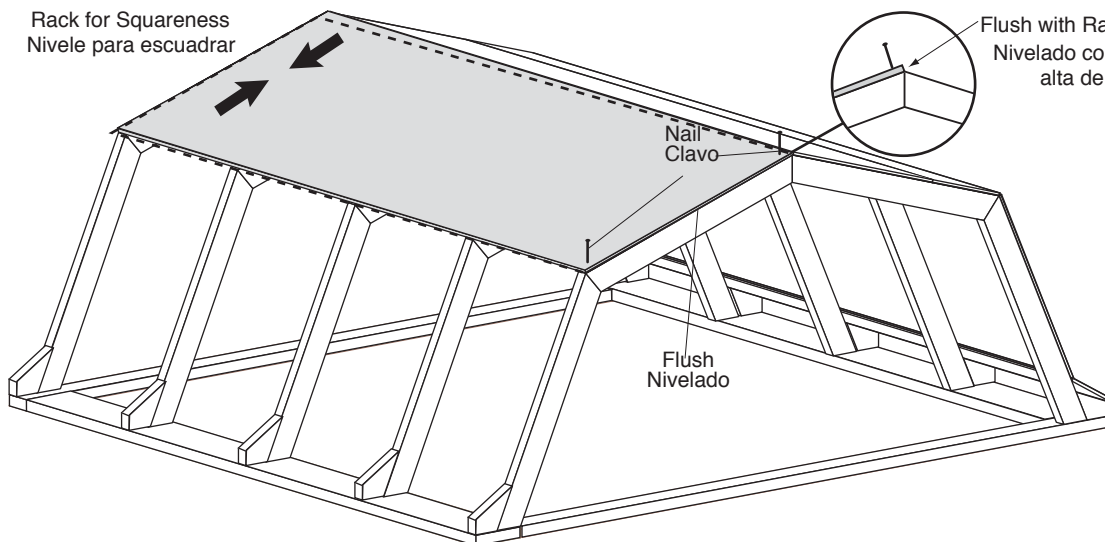

Alineando un techo

Flush with Rafter Peak
Nivelado con la parte más alta de las vigas

Position panel flush with outside front edge of rafter and nail in two corners as shown. Rack panel square by moving opposite end up or down until panel is flush along peak of rafters and secure with one nail in each corner. Ensure spacing of center rafters and nail as instructed.

Posicione los paneles nivelados con el borde delantero exterior de la viga y clave en las dos esquinas como en el dibujo. Alinee escuadra el panel por mover los extremos opuestos arriba o abajo hasta que el panel esté nivelado a lo largo del punto más alto de las vigas, y fíjelo con un clavo en cada esquina. Compruebe el espacio de las vigas centrales y clave como indicado.

WALL #9

3"(7.6 cm)

x 20

MURO #9

Top
Parte Superior

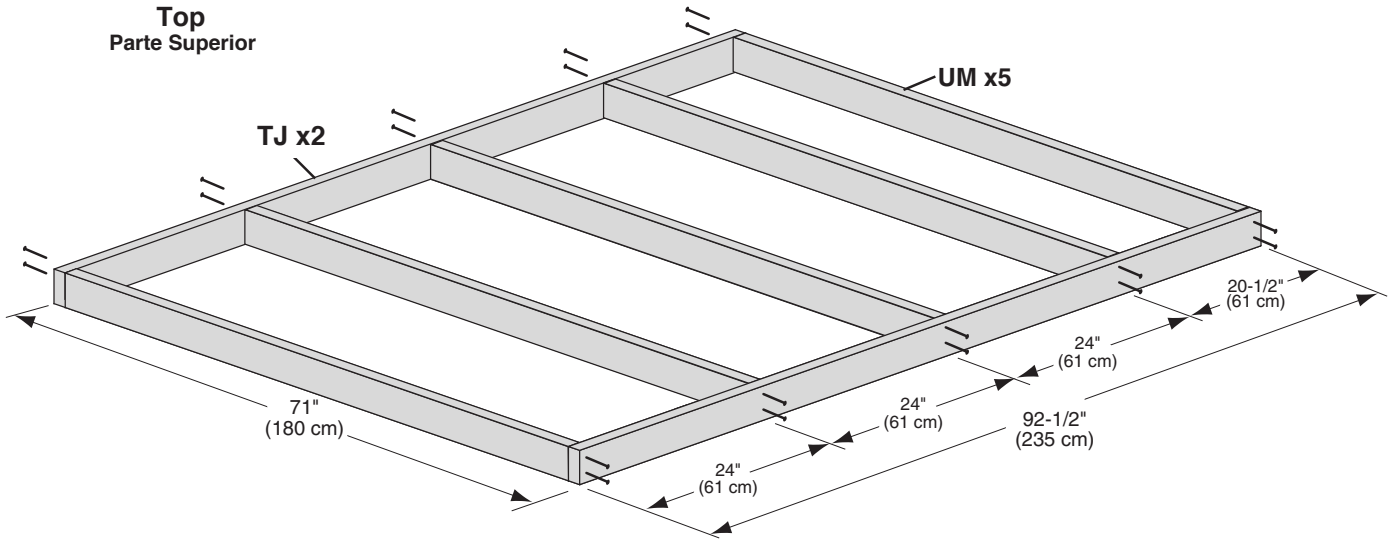

End View
Vista terminal

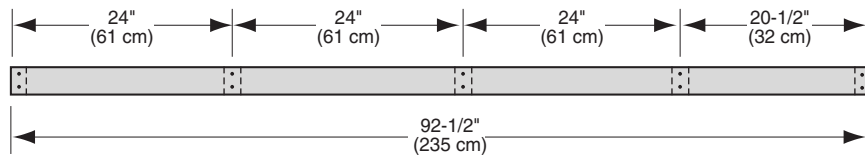

WALL #9

2"(5 cm)

x 90

MURO #9

See Page 8 For Building Tip!!!

¡Ver la página 8 para un consejo!!!

Top
Parte Superior

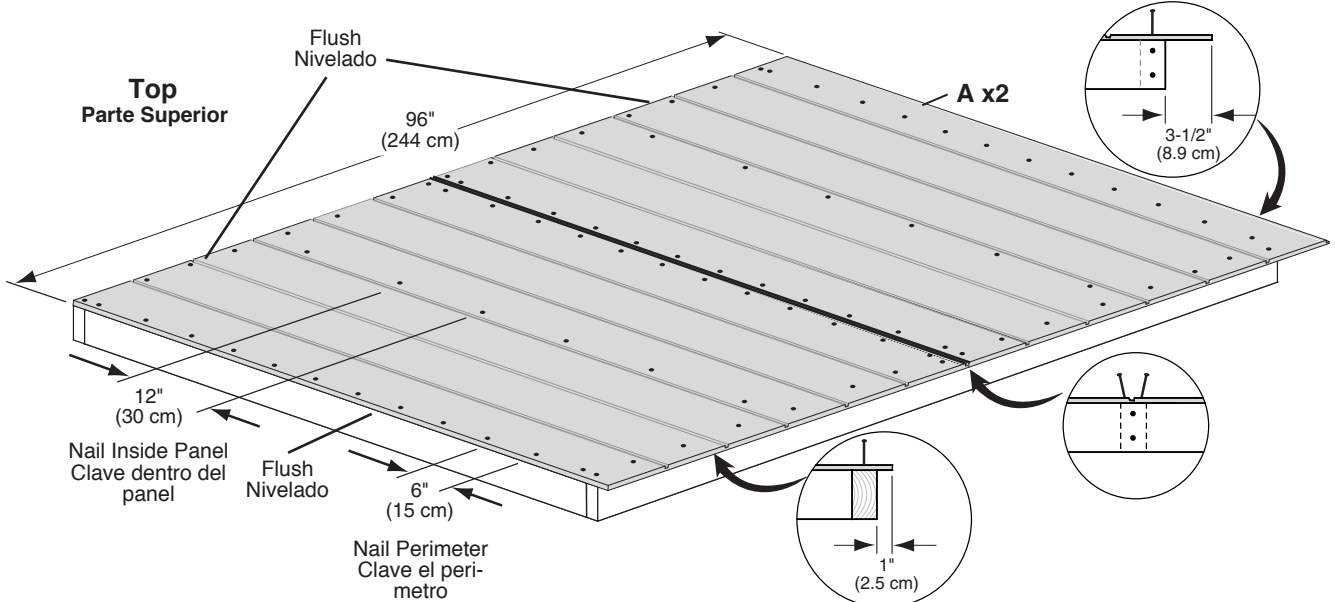

End View
Vista terminal

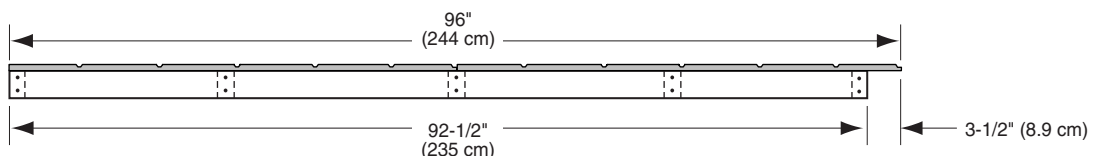

WALL #10

3"(7.6 cm)

x 28

MURO #10

Top
Parte Superior

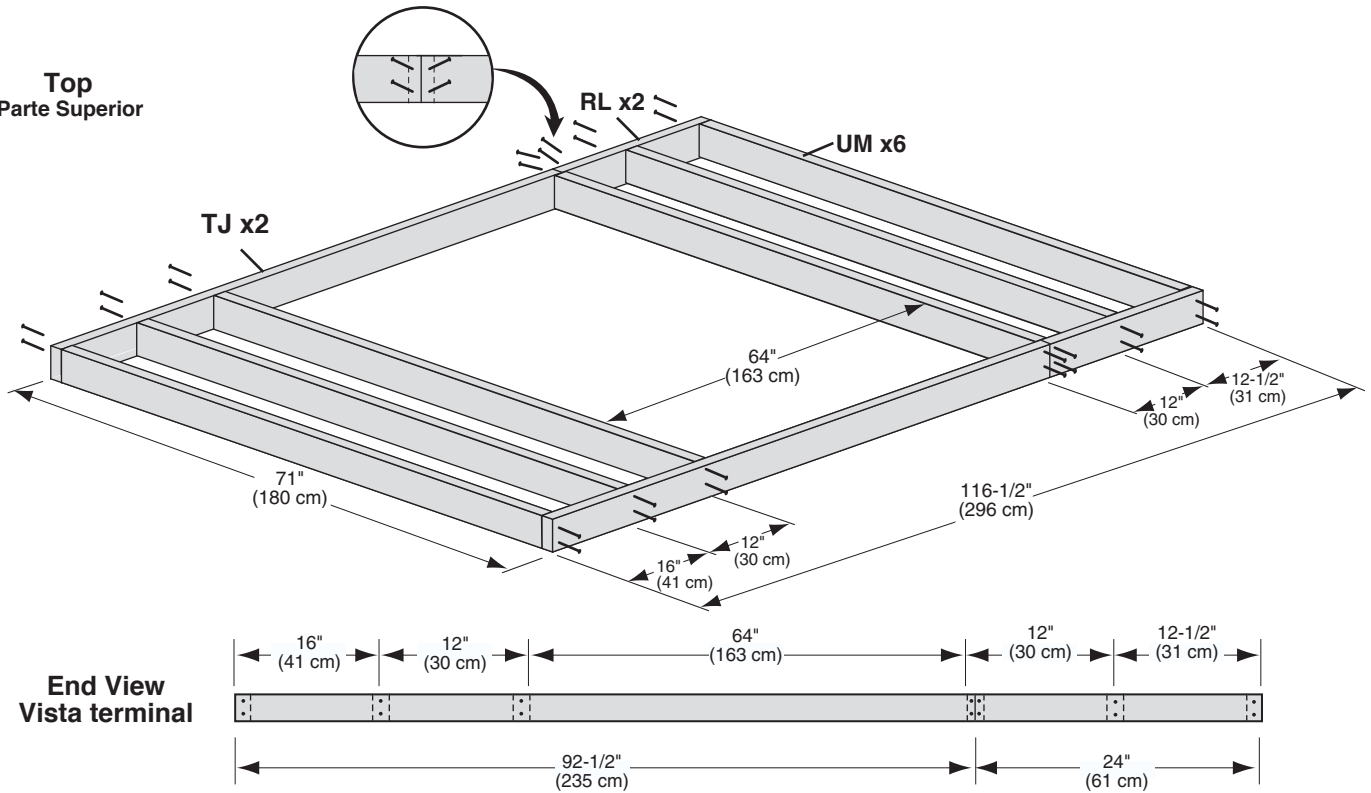

WALL #10

2"(5 cm)

x 124

MURO #10

See Page 8 For Building Tip!!!

¡Ver la página 8 para un consejo!!!

Top
Parte Superior

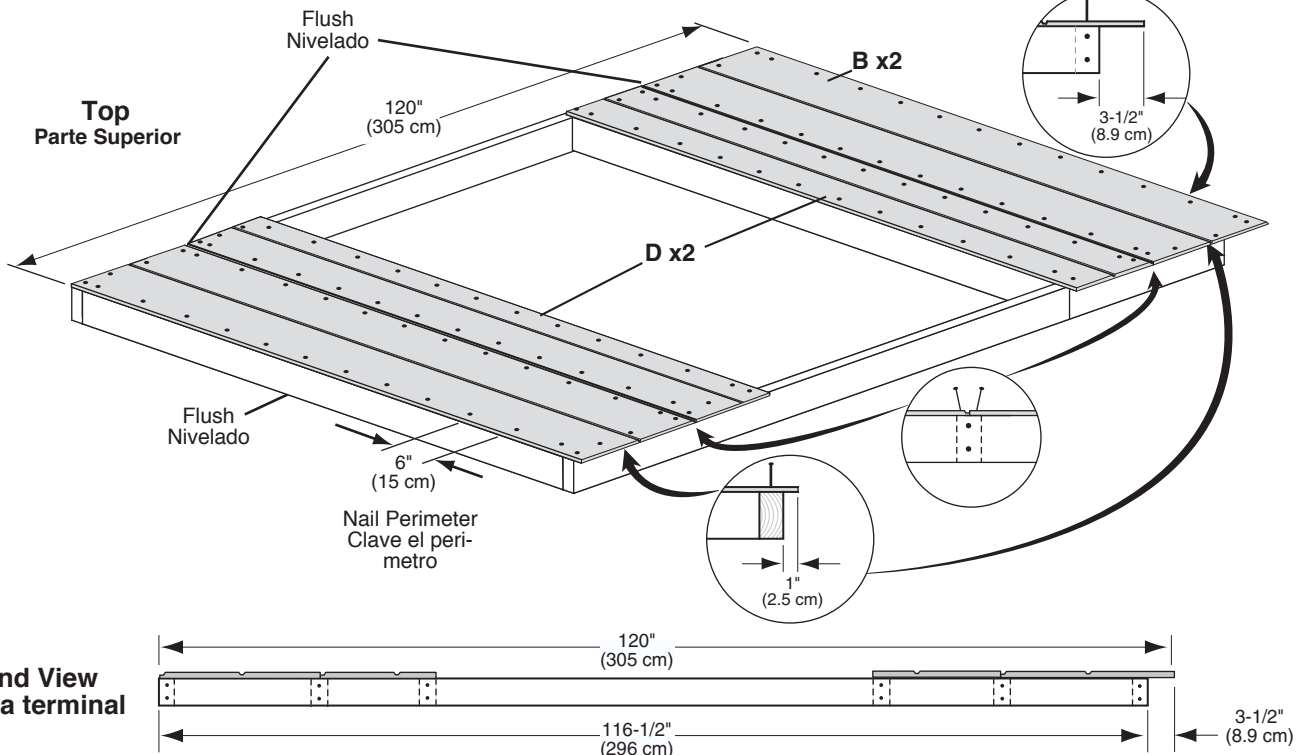

WALL #11

3"(7.6 cm)

x 28

MURO #11

Top
Parte Superior

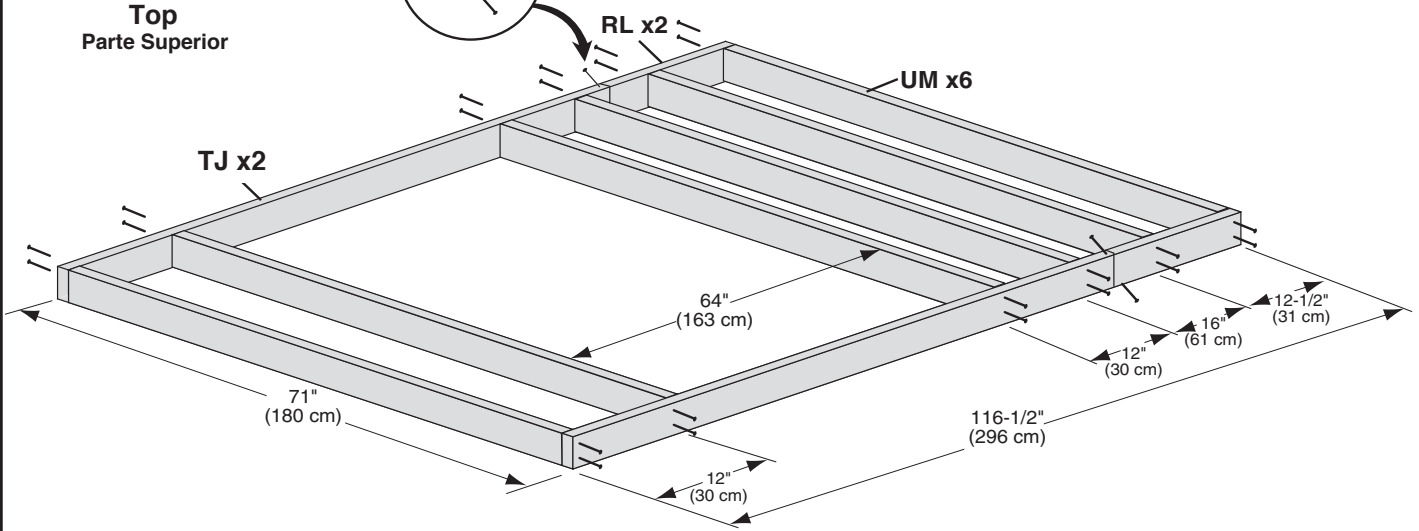
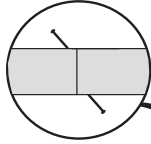

End View
Vista terminal

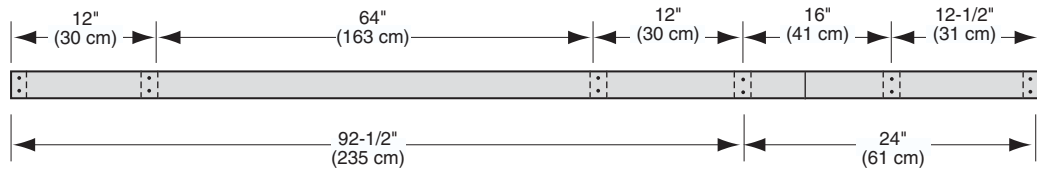

WALL #11

2"(5 cm)

x 124

MURO #11

See Page 8 For Building Tip!!!

¡Ver la página 8 para un consejo!!!

Top
Parte Superior

Flush
Nivelado

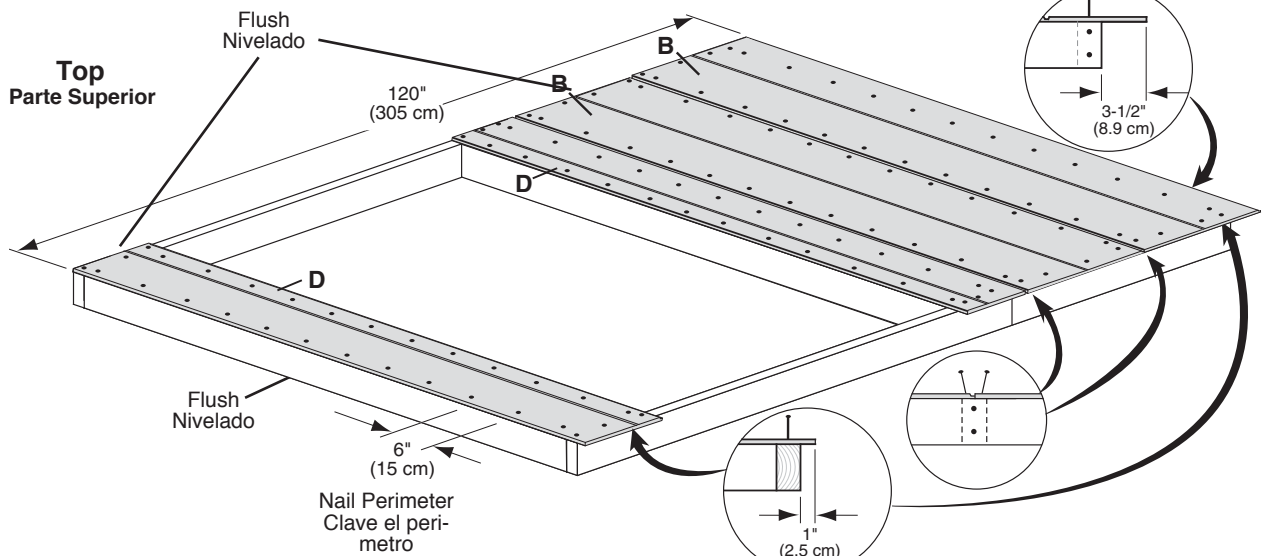

End View
Vista terminal

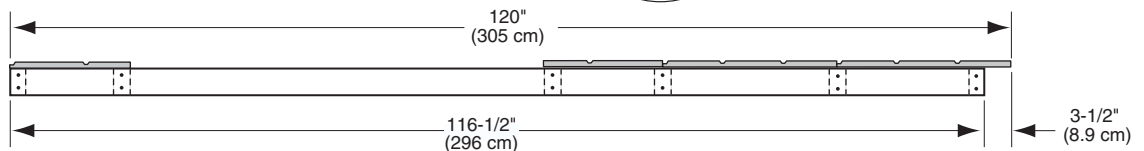

WALL #12

3" (7.6 cm)

x 28

MURO #12

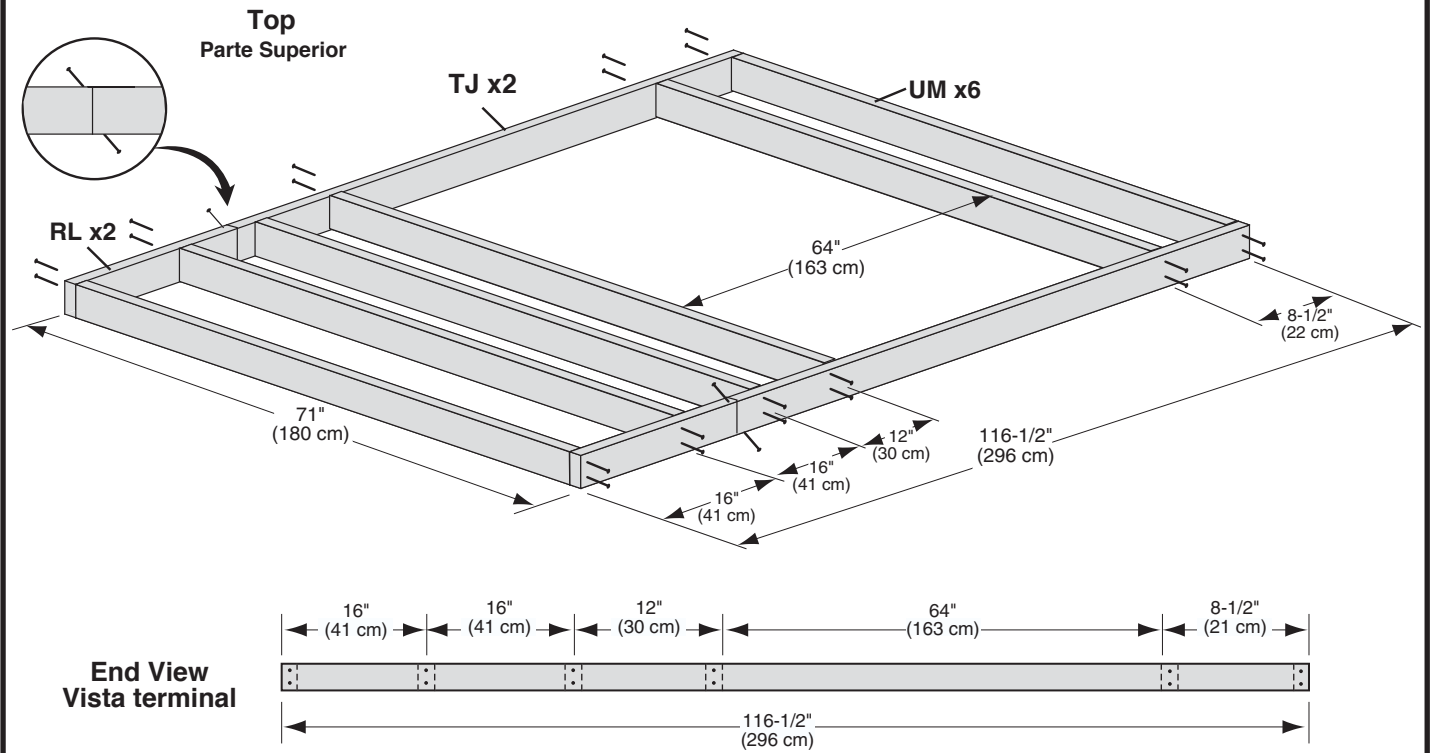

WALL #12

2" (5 cm)

x 124

MURO #12

See Page 8 For Building Tip!!!

¡Ver la página 8 para un consejo!!!

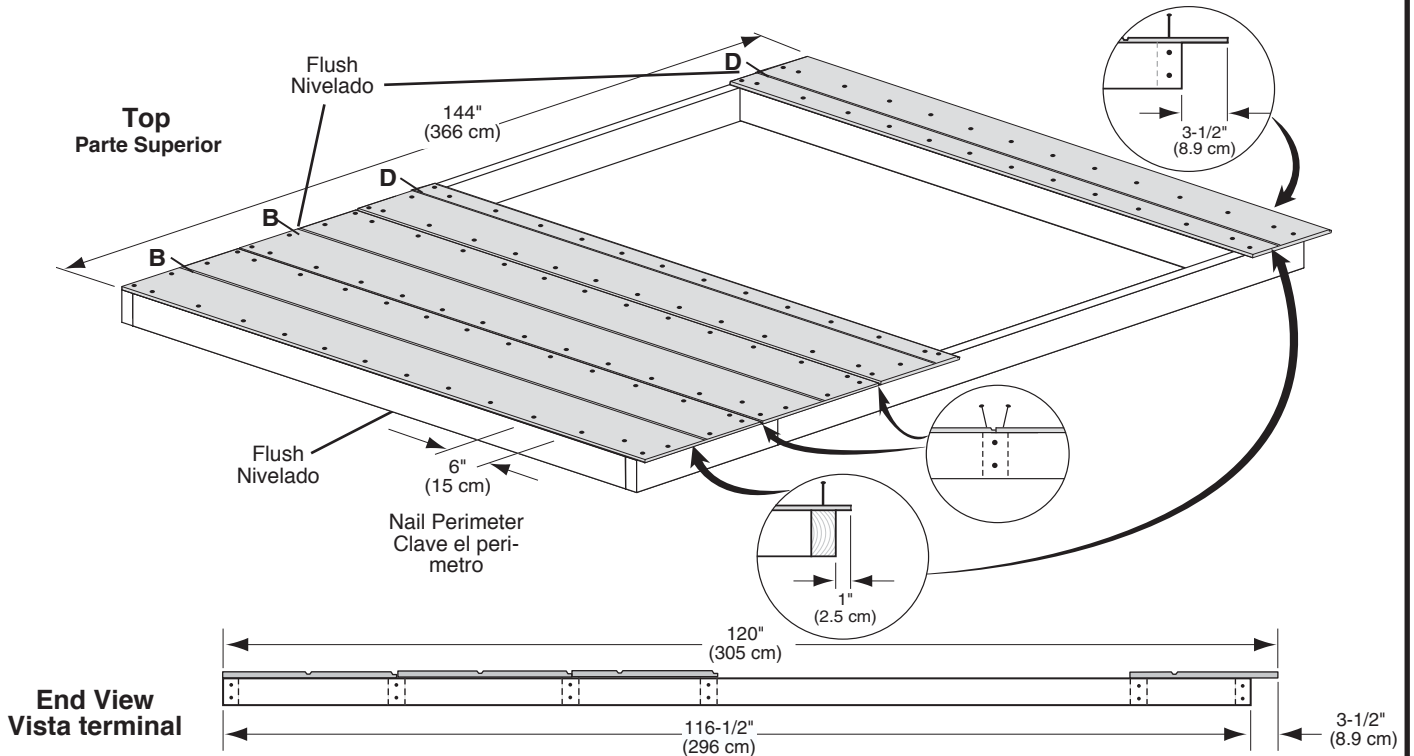

WALL #13

3"(7.6 cm)

x 20

MURO #13

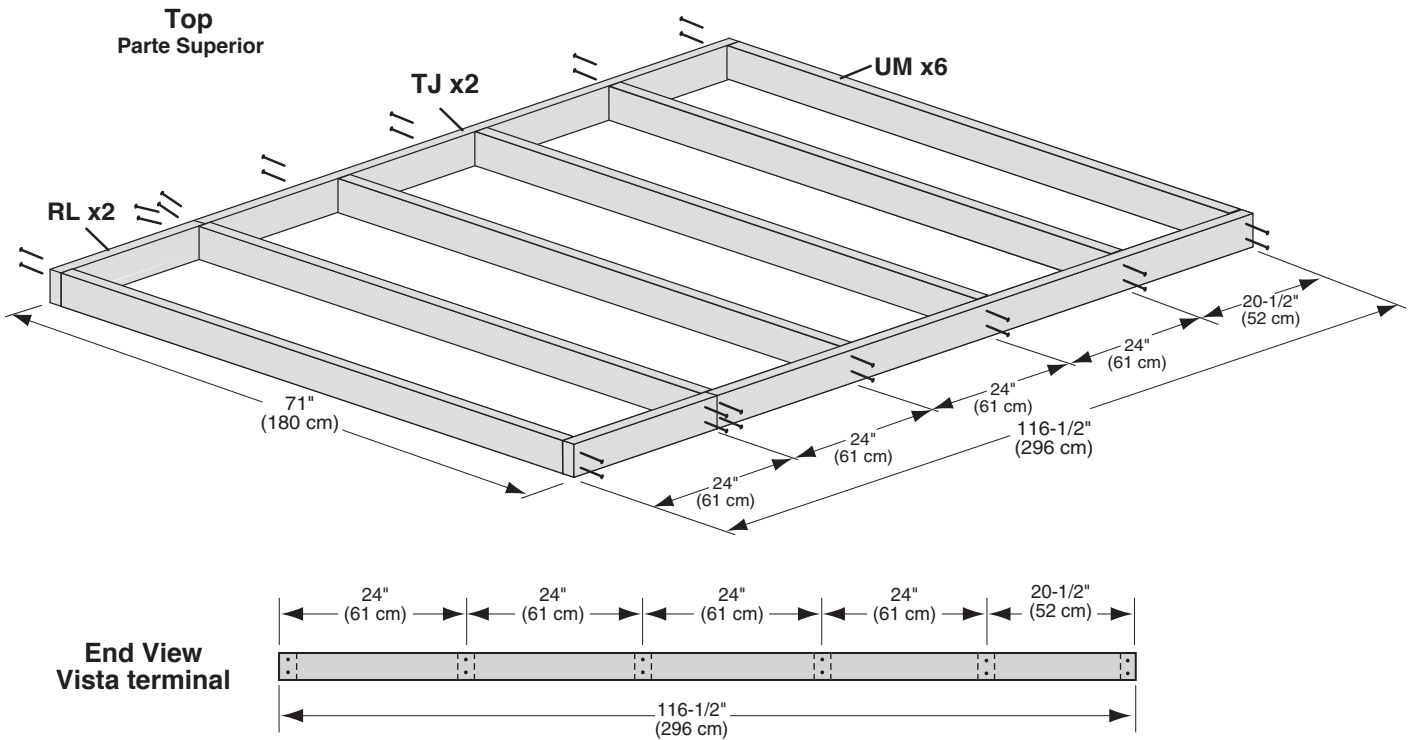

WALL #13

2"(5 cm)

x 90

MURO #13

See Page 8 For Building Tip!!!

¡Ver la página 8 para un consejo!!!

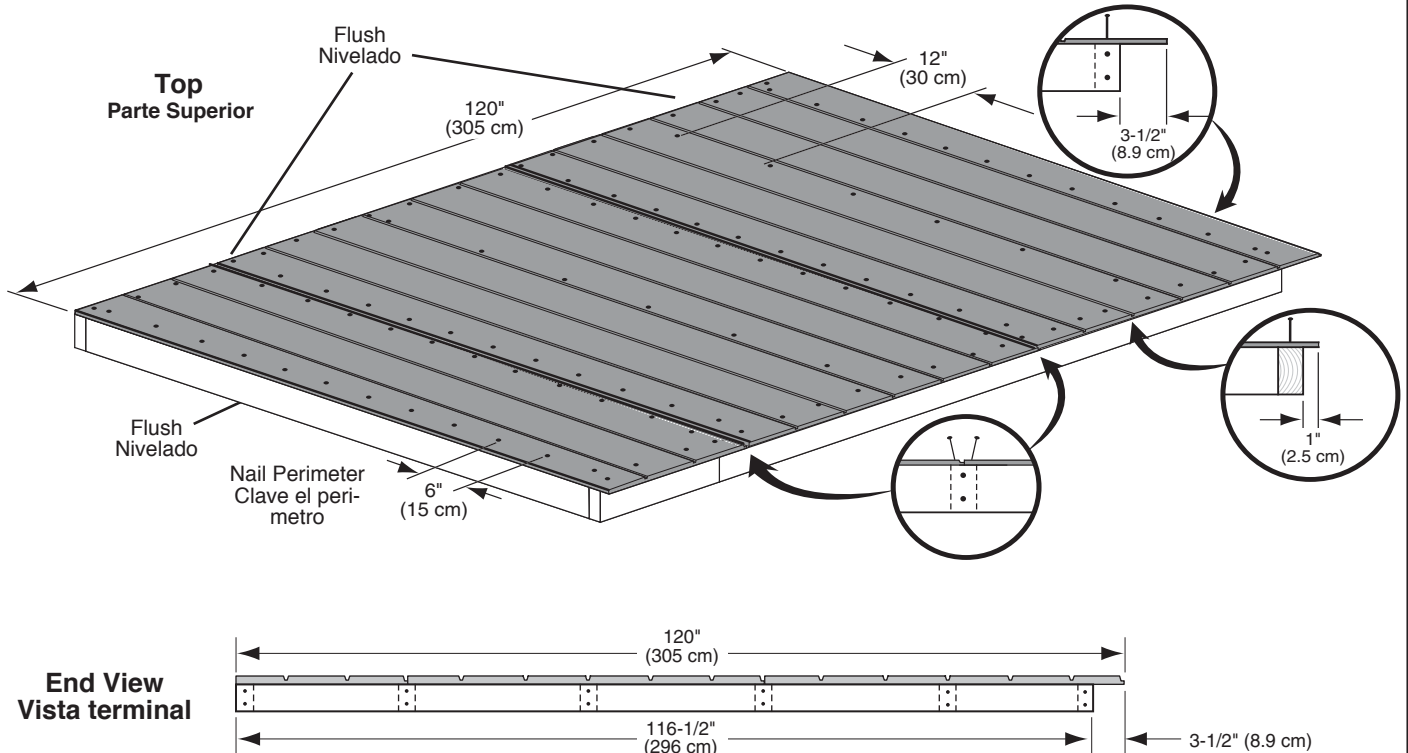

WALL #14

3"(7.6 cm)

x 28

MURO #14

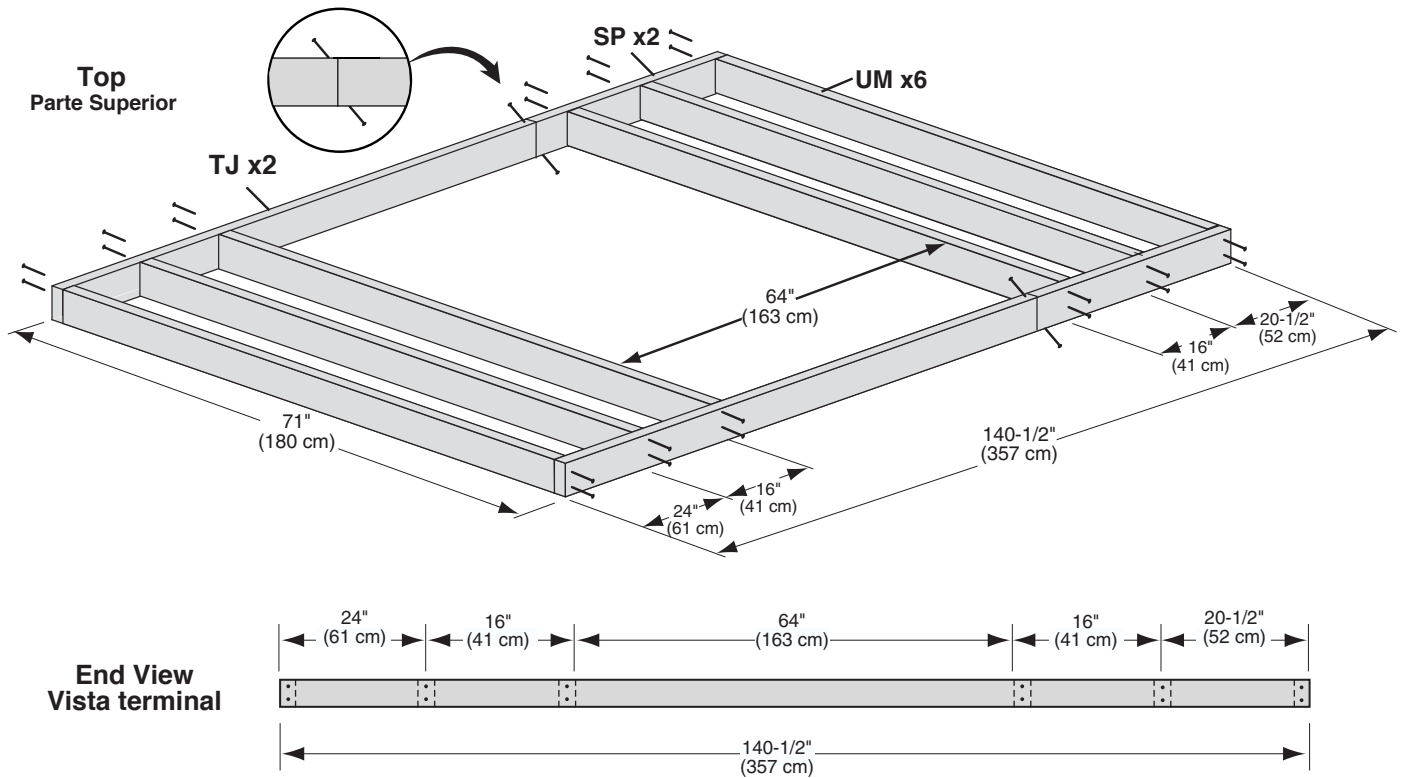

WALL #14

2"(5 cm)

x 124

MURO #14

See Page 8 For Building Tip!!!

¡Ver la página 8 para un consejo!!!

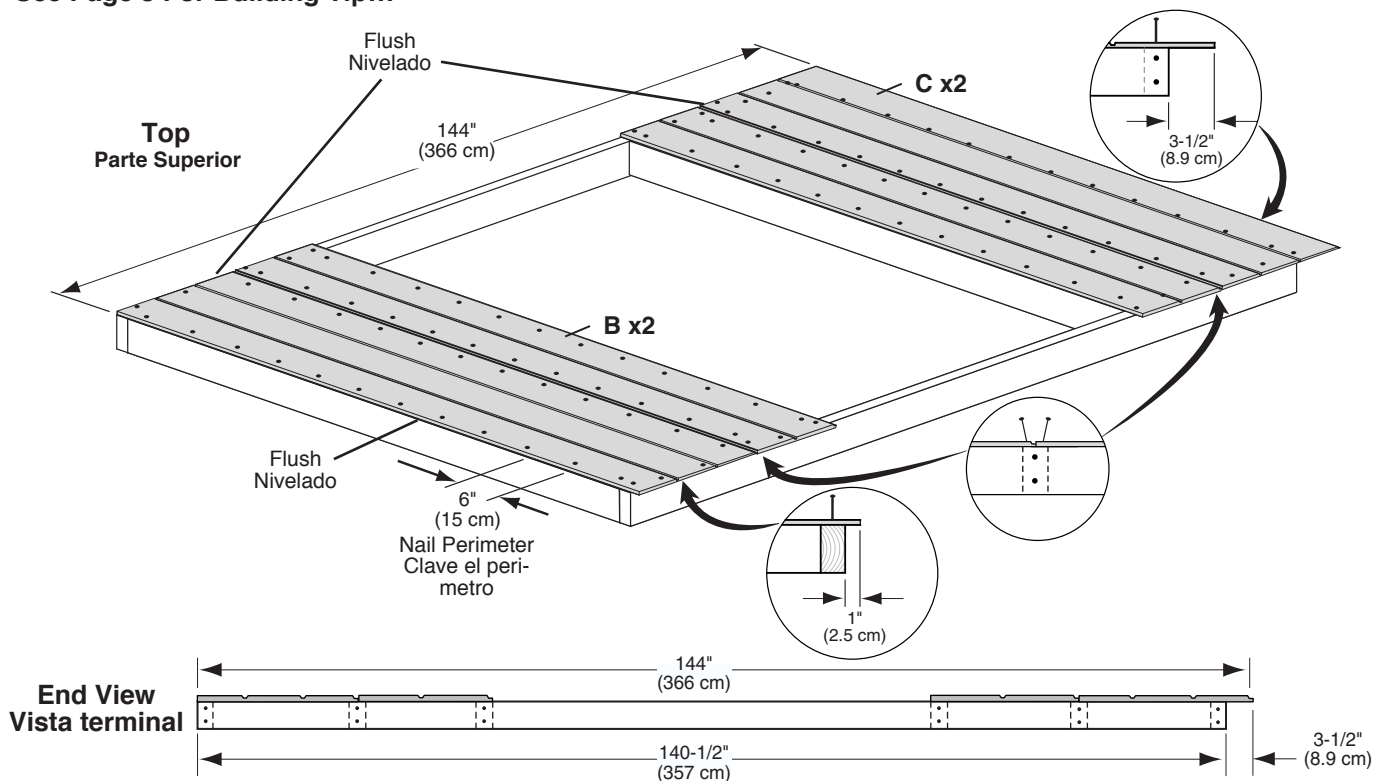

WALL #15

3"(7.6 cm)

x 28

MURO #15

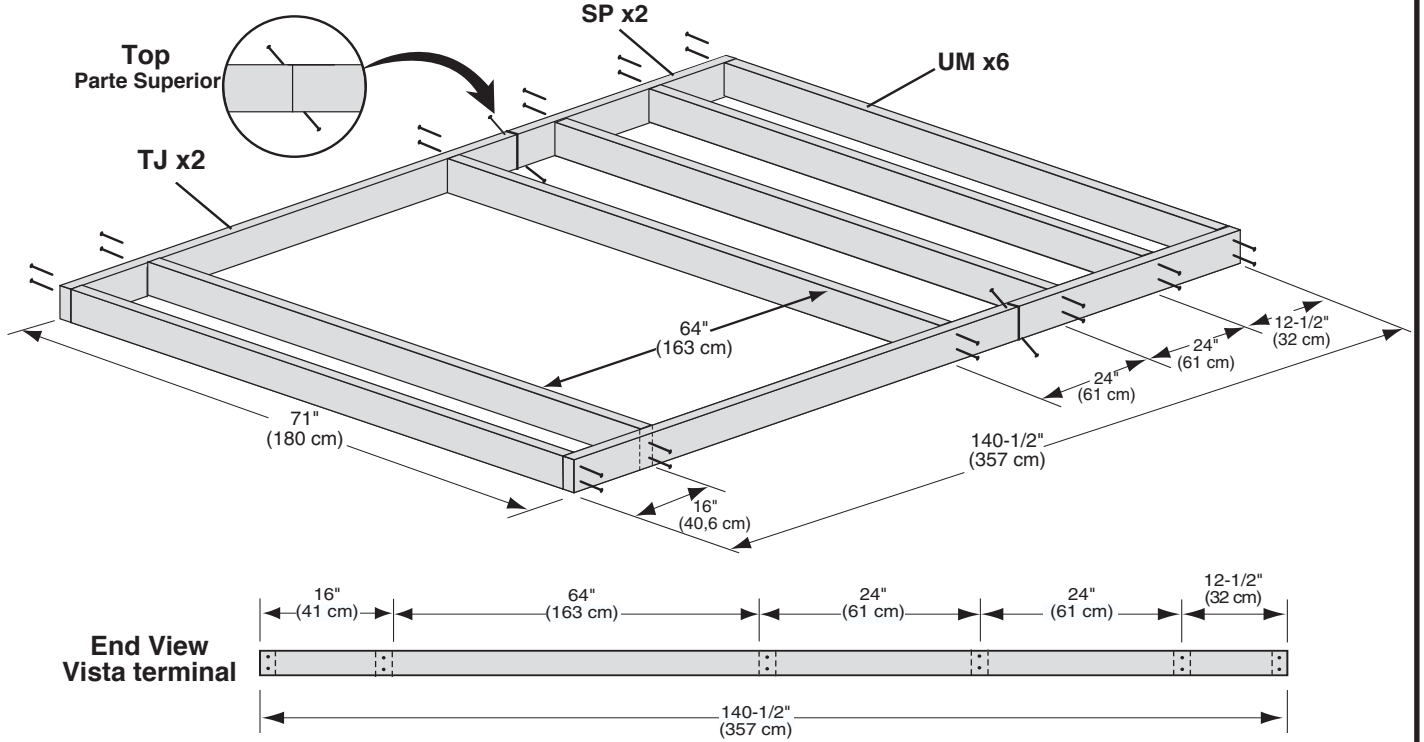

WALL #15

2"(5 cm)

x 124

MURO #15

See Page 8 For Building Tip!!!

¡Ver la página 8 para un consejo!!!

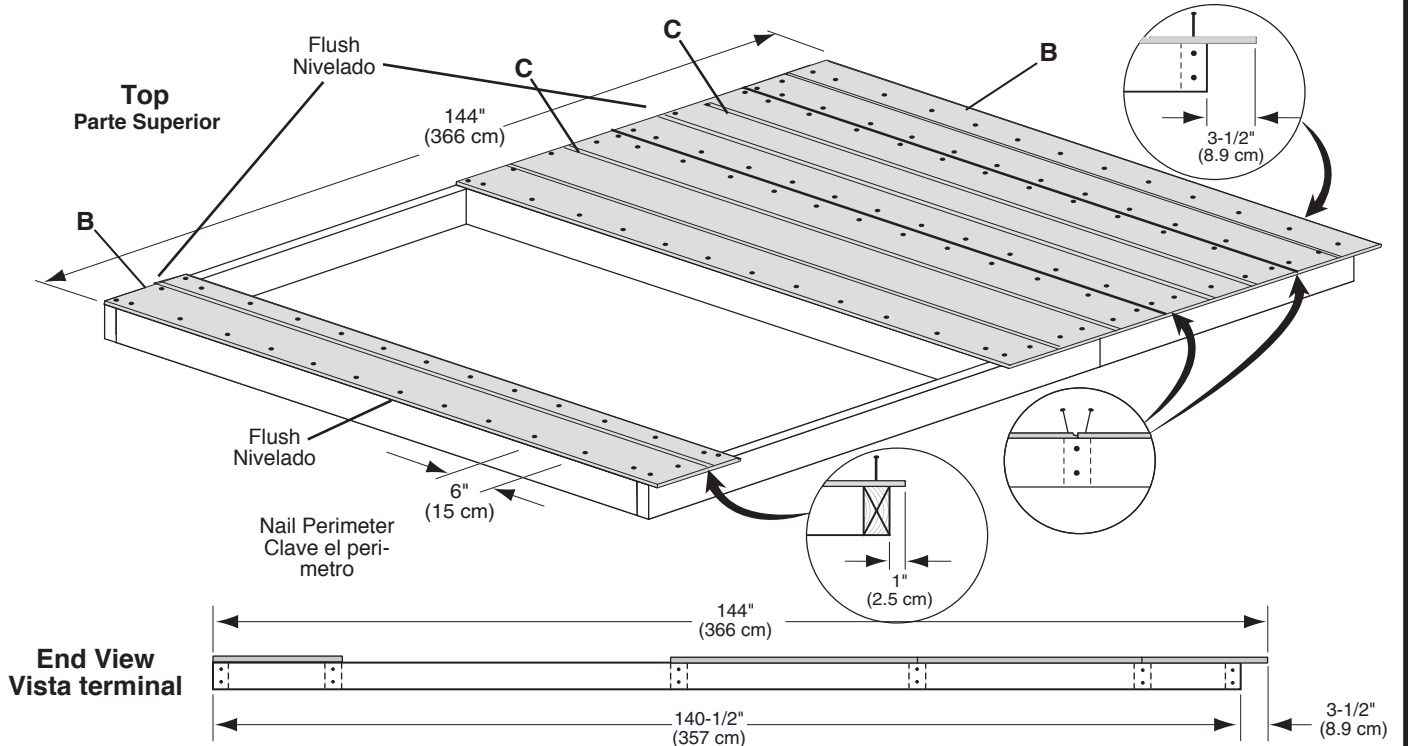

WALL #16

3"(7.6 cm)

x 28

MURO #16

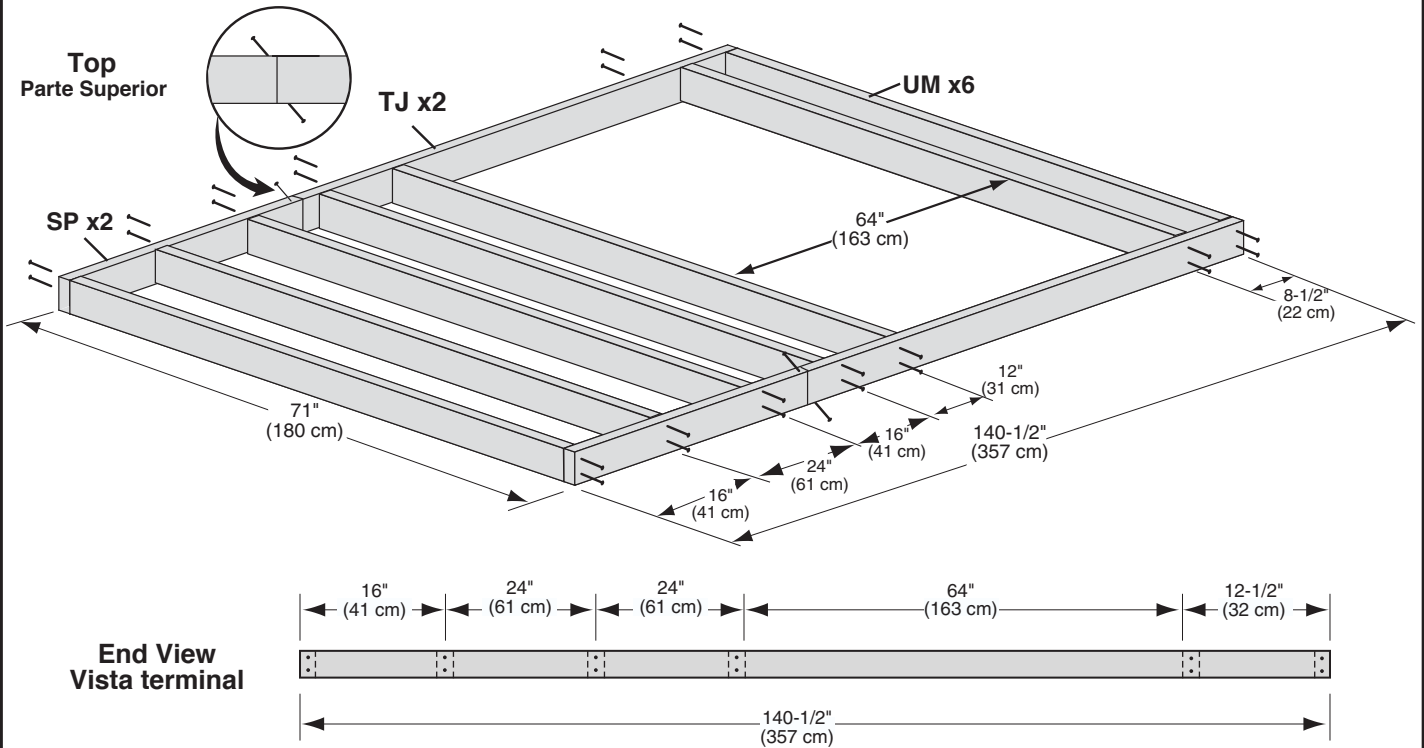

WALL #16

2"(5 cm)

x 124

MURO #16

See Page 8 For Building Tip!!!

¡Ver la página 8 para un consejo!!!

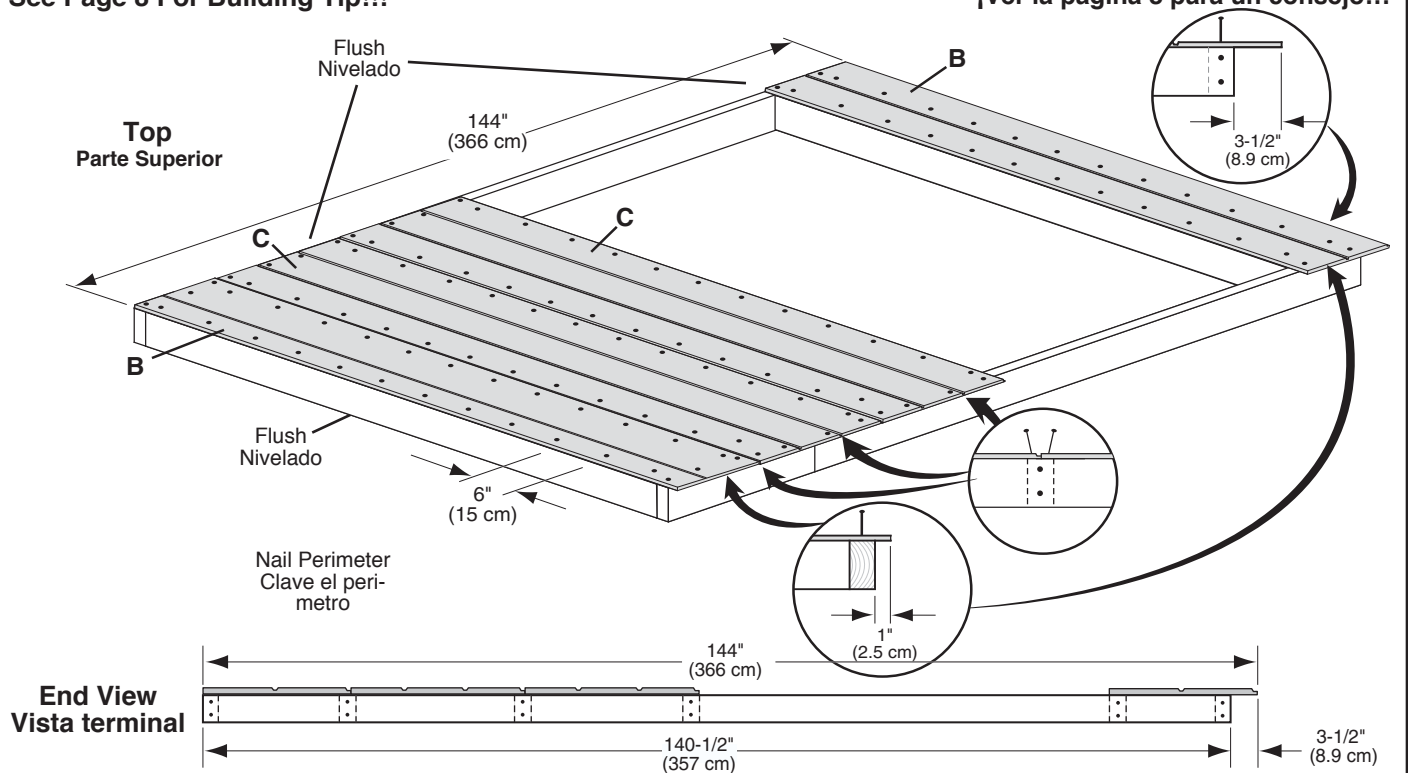

WALL #17

3"(7.6 cm)

x 32

MURO #17

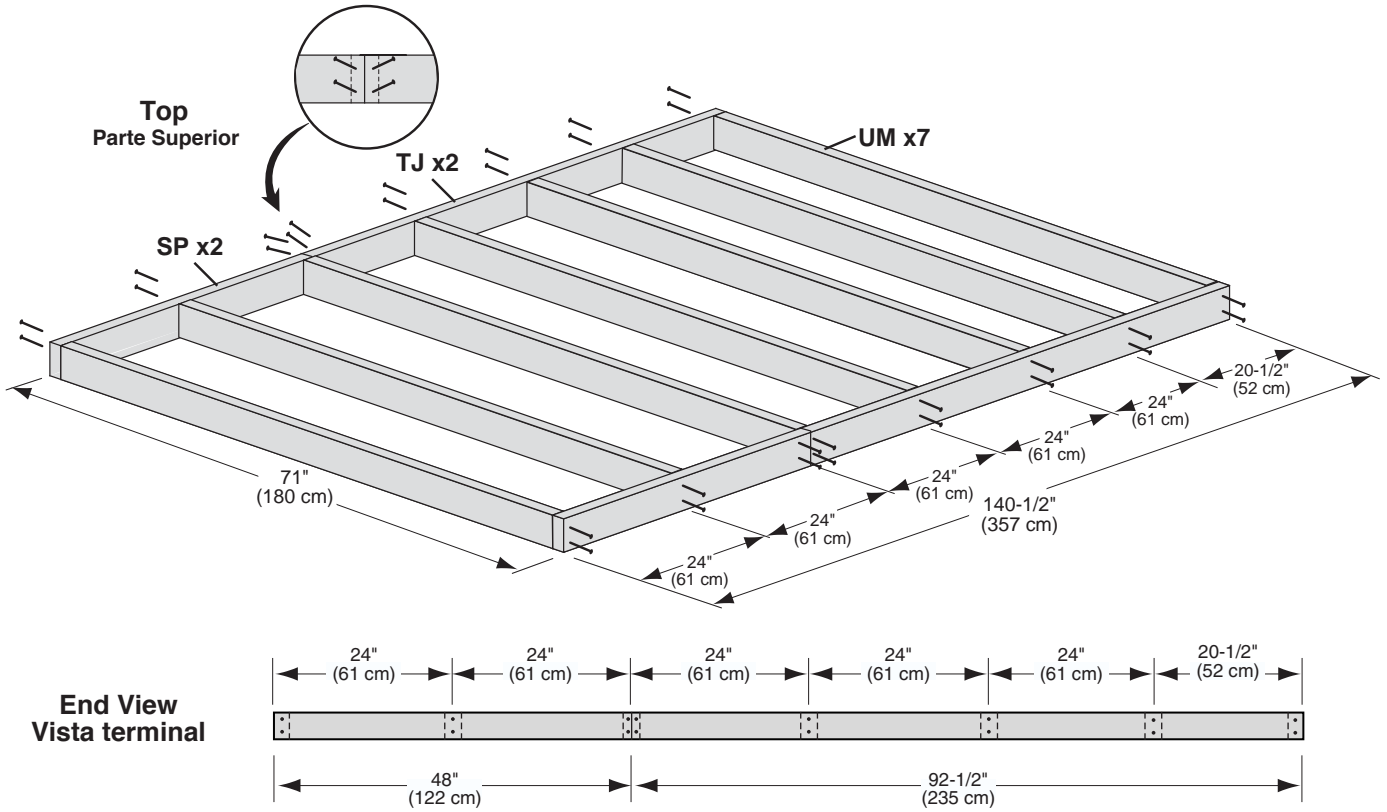

WALL #17

2"(5 cm)

x 135

MURO #17

See Page 8 For Building Tip!!!

¡Ver la página 8 para un consejo!!!

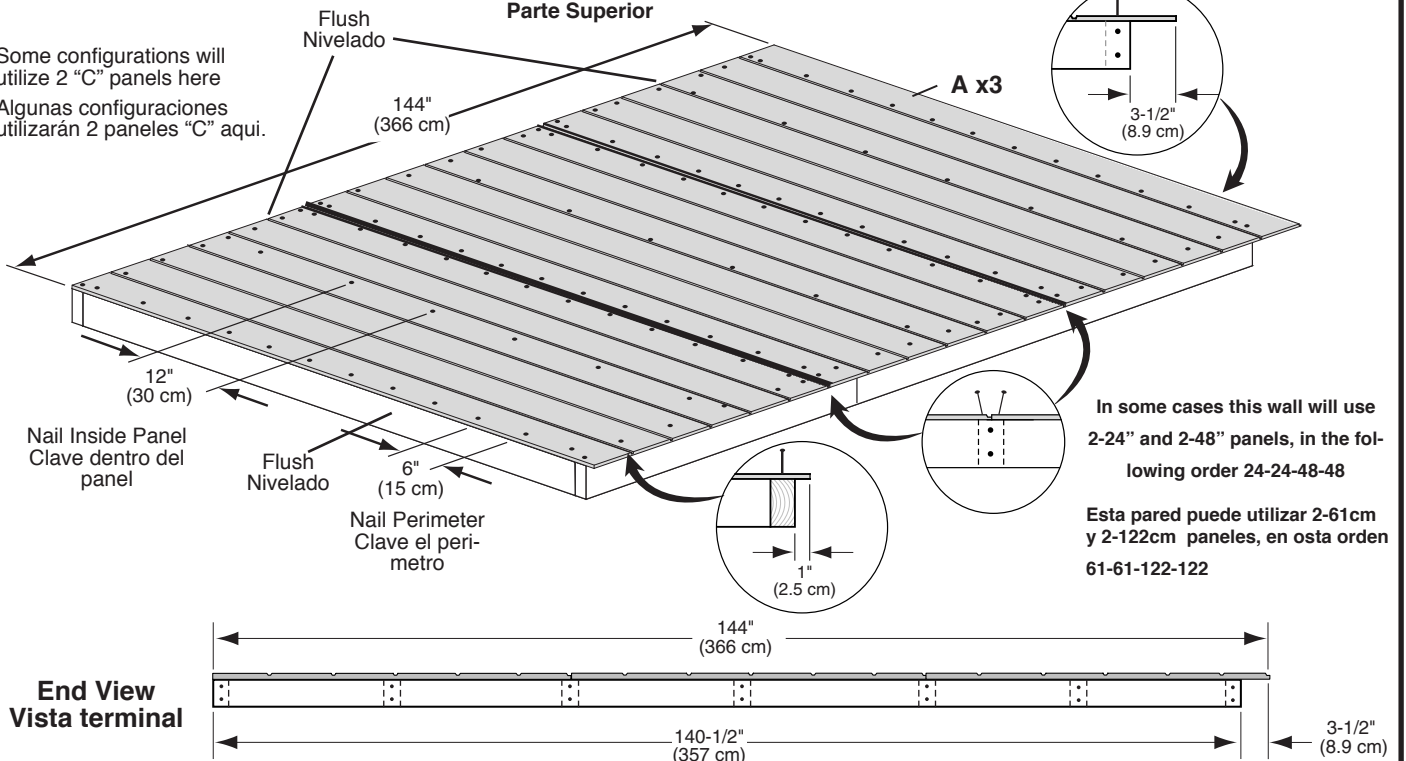

WALL #18

3"(7.6 cm)

x 40

MURO #18

Top
Parte Superior

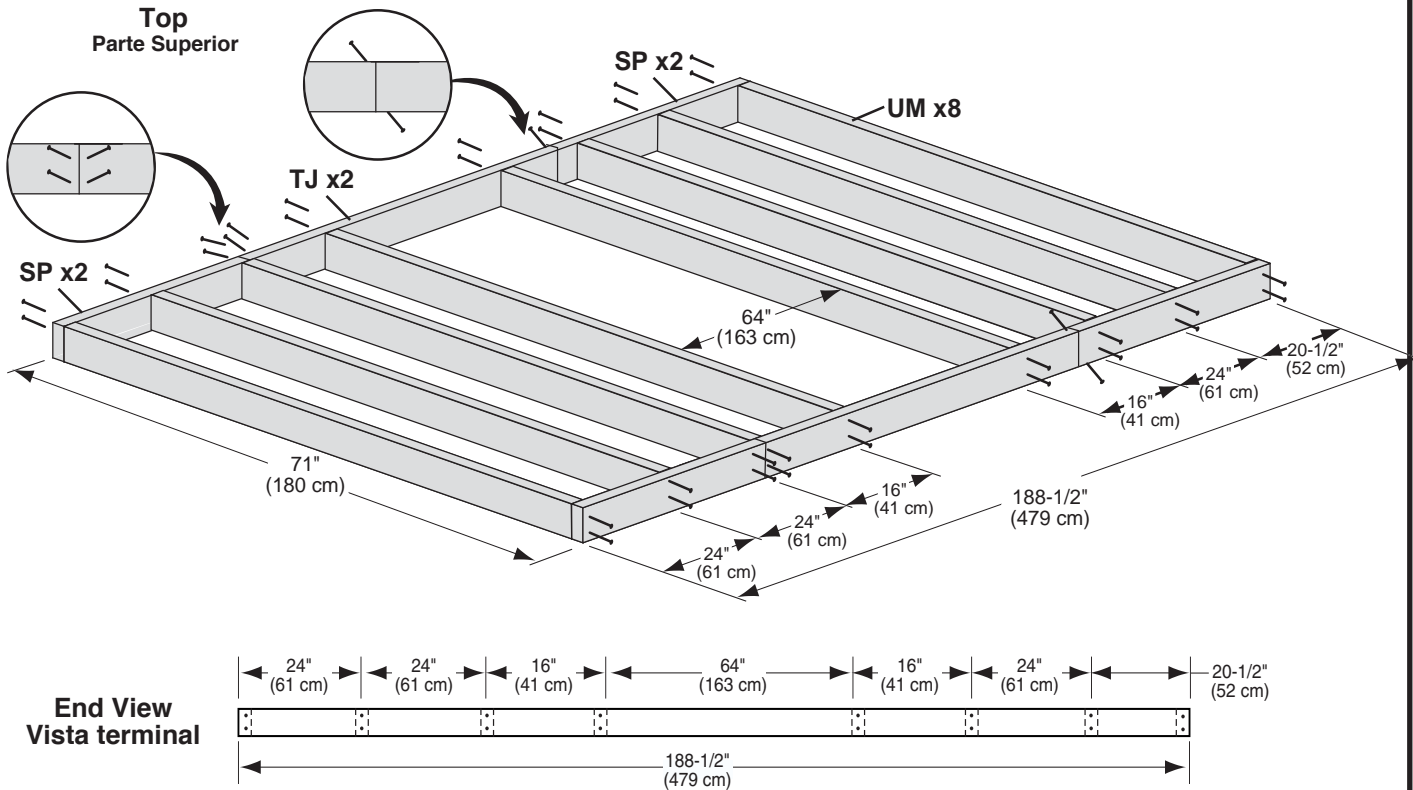

WALL #18

2"(5 cm)

x 188

MURO #18

See Page 8 For Building Tip!!!

¡Ver la página 8 para un consejo!!!

Top
Parte Superior

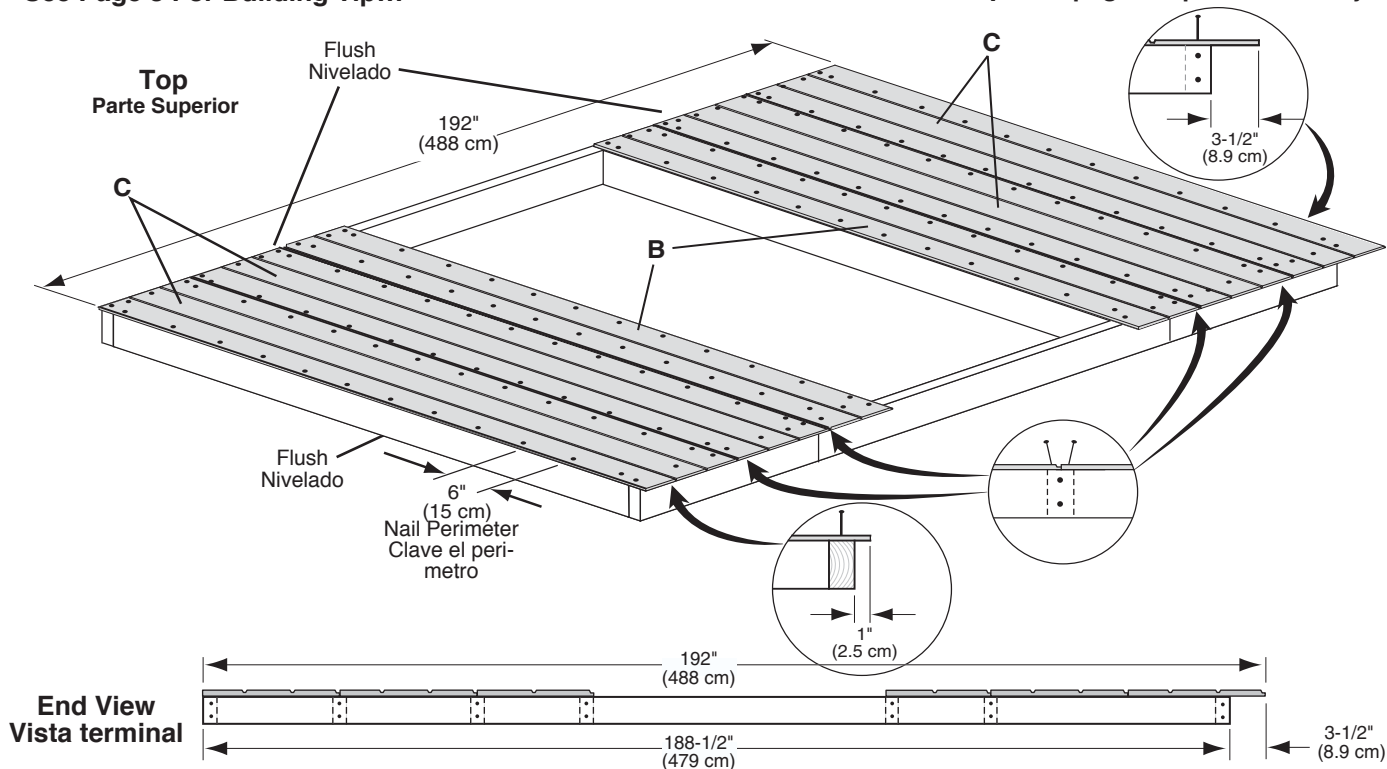

WALL #19

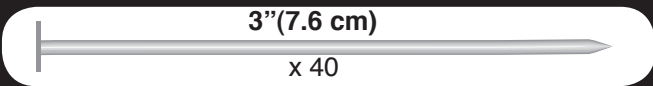

MURO #19

Top
Parte Superior

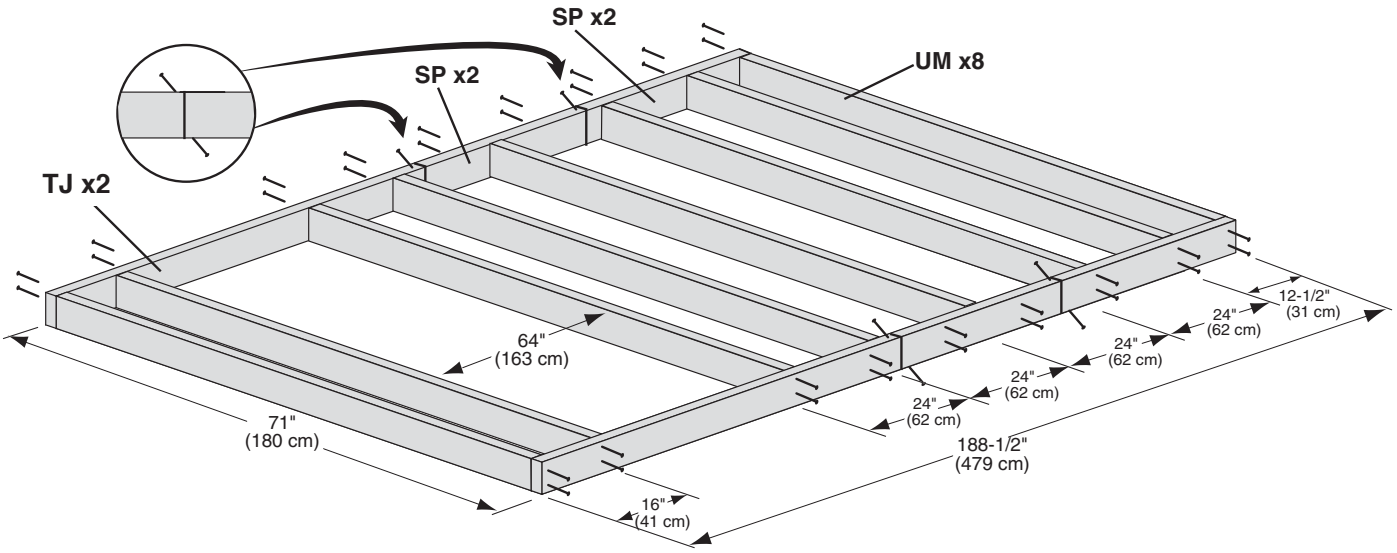

End View
Vista terminal

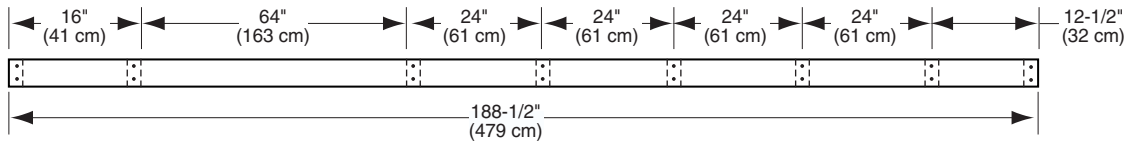

WALL #19

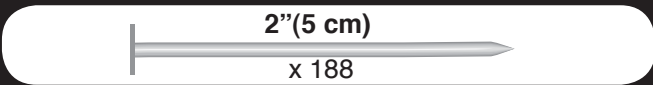

MURO #19

See Page 8 For Building Tip!!!

¡Ver la página 8 para un consejo!!!

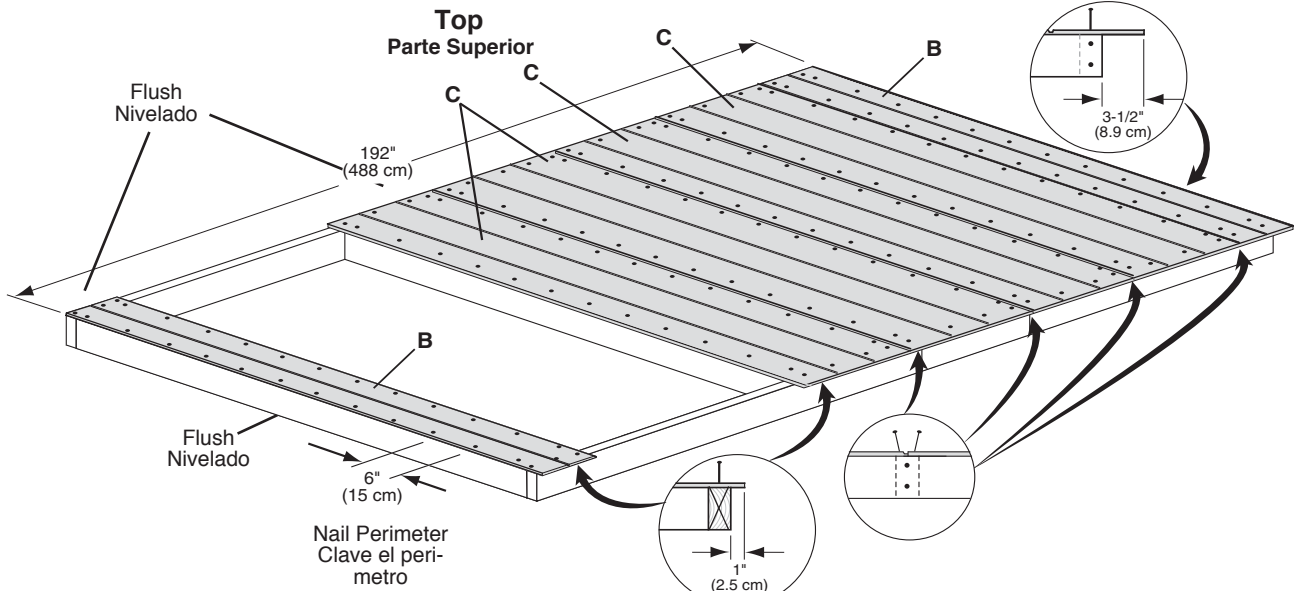

End View
Vista terminal

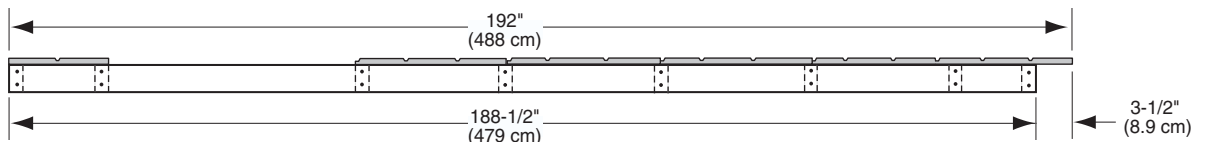

WALL #20

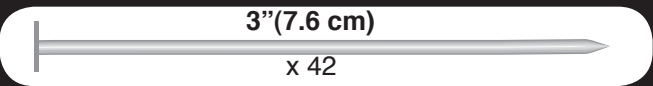

MURO #20

Top
Parte Superior

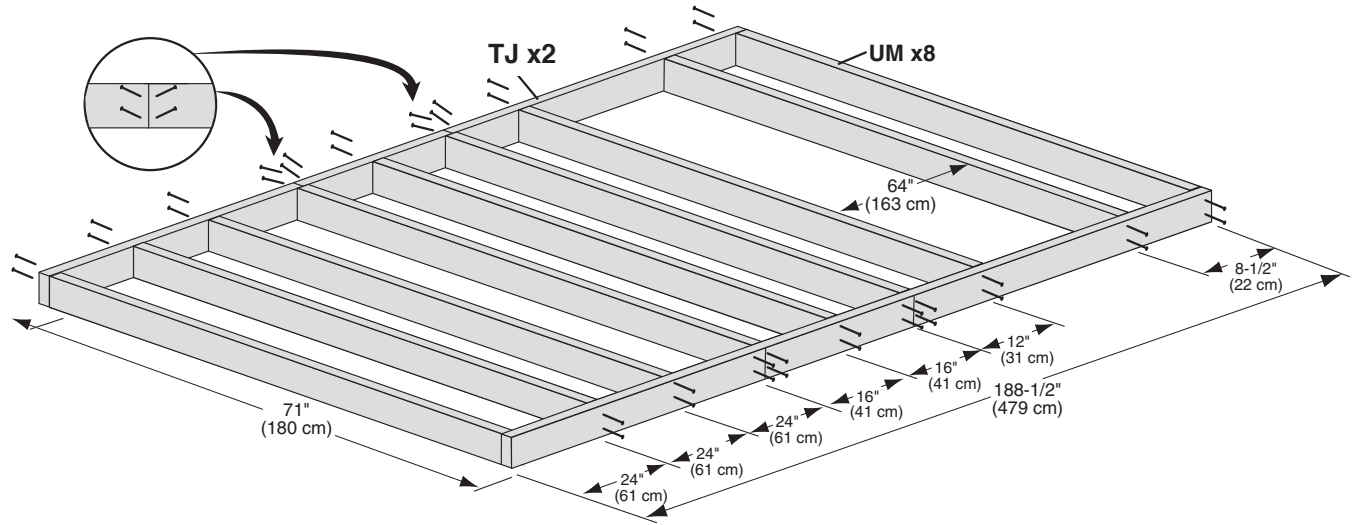

End View
Vista terminal

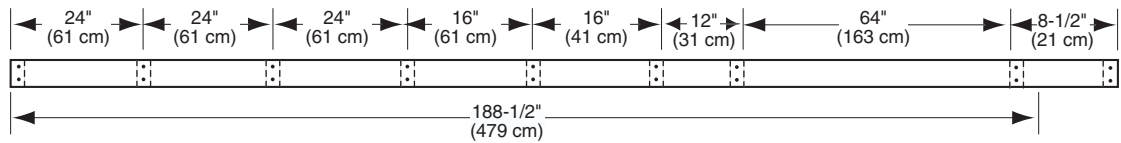

WALL #20

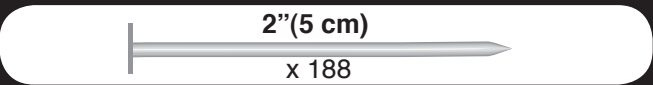

MURO #20

See Page 8 For Building Tip!!!

¡Ver la página 8 para un consejo!!!

Top
Parte Superior

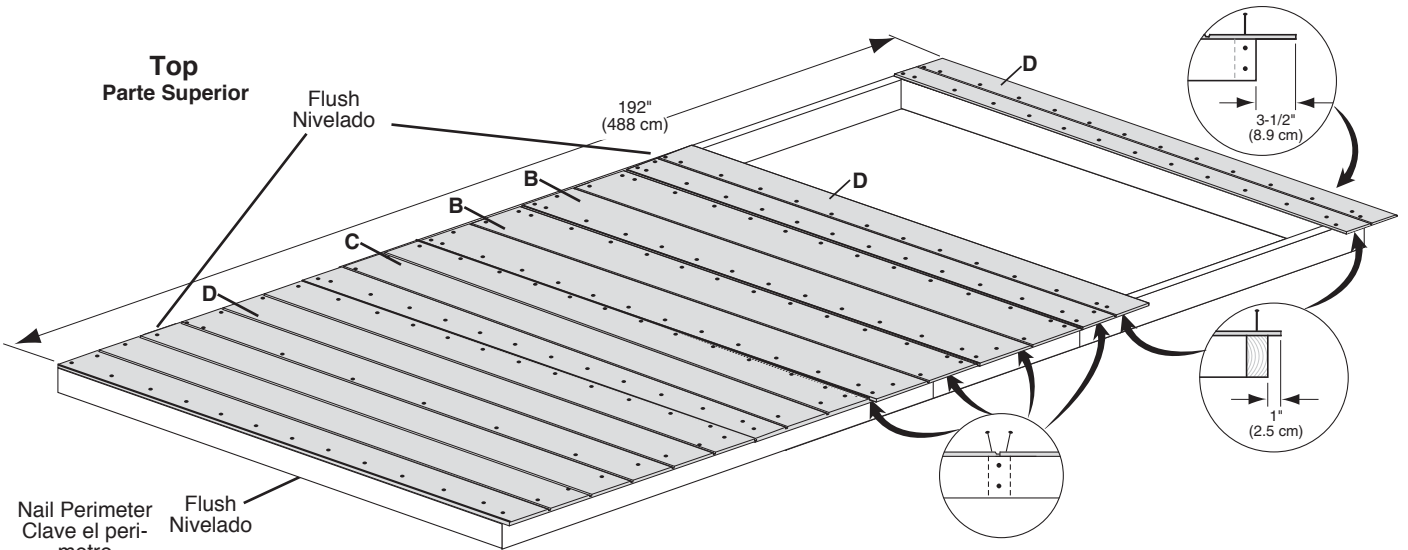

End View
Vista terminal

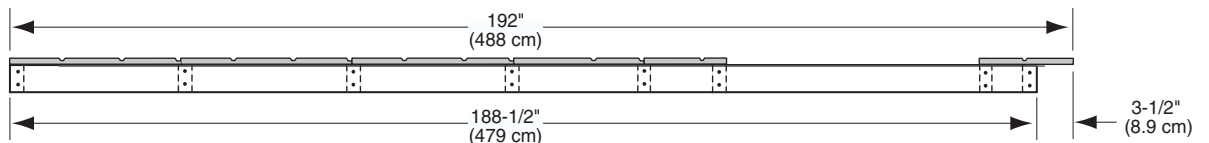

WALL #21

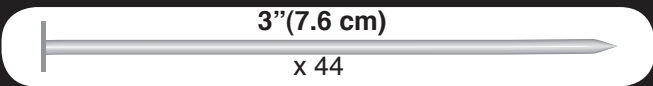

MURO #21

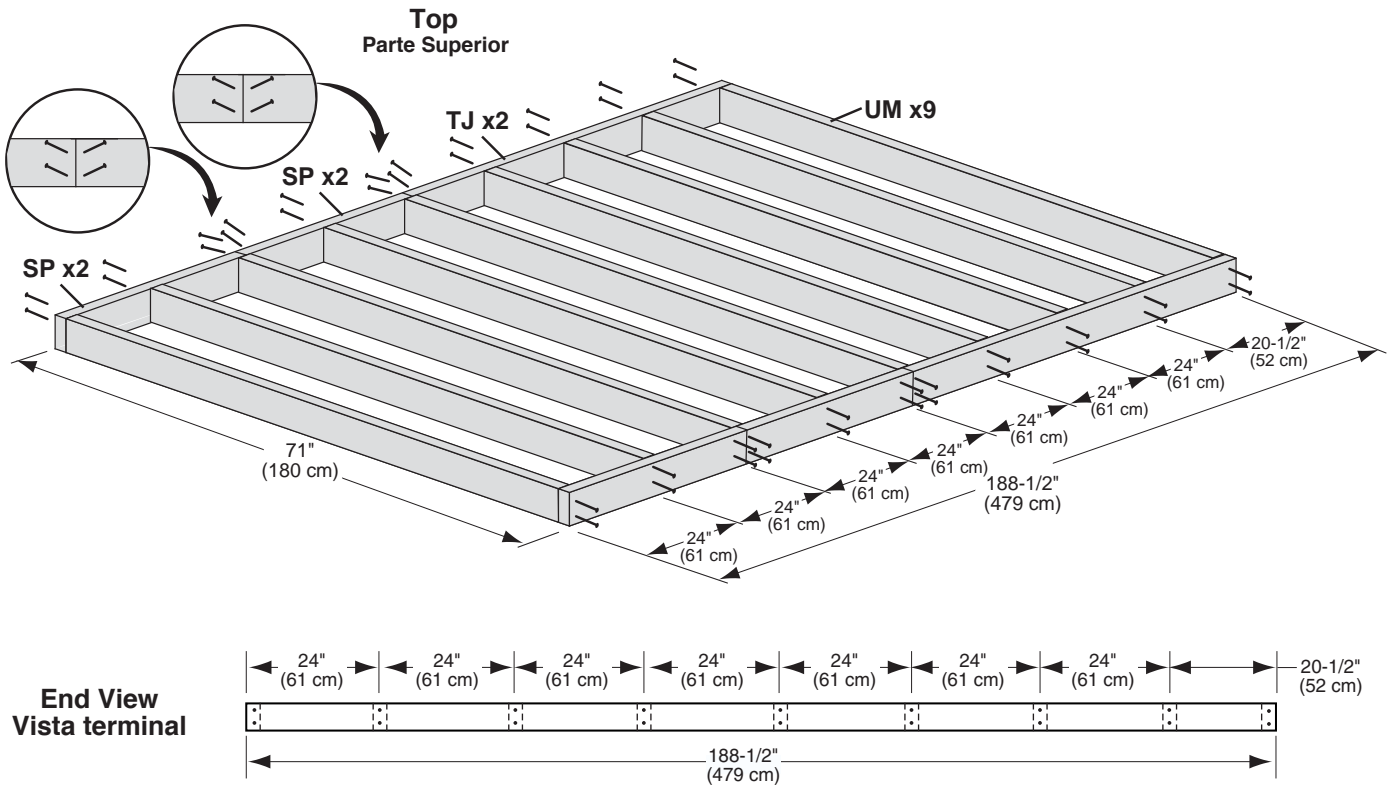

WALL #21

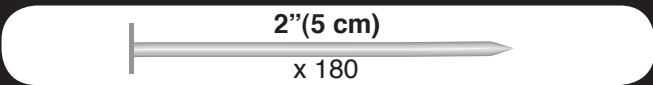

MURO #21

See Page 8 For Building Tip!!!

¡Ver la página 8 para un consejo!!!

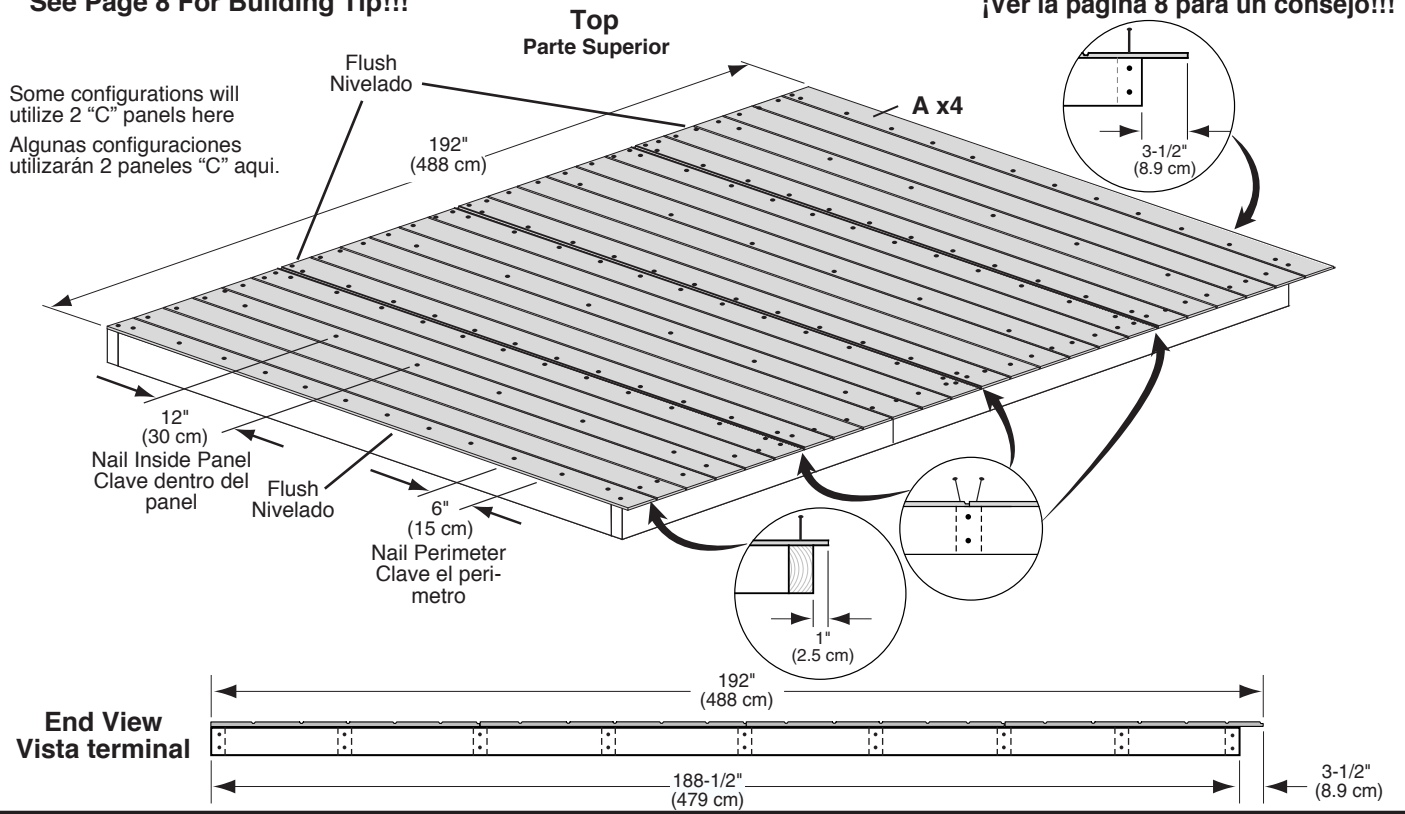

ERECTING WALL

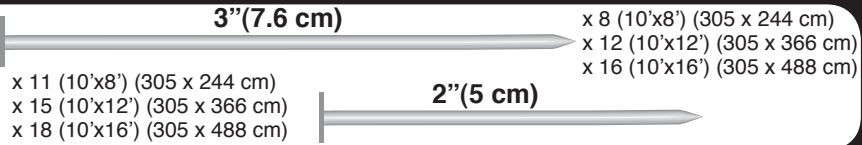

CONSTRUYENDO LOS MUROS

See Page 7 For Building Tip!!!

¡Ver la página 7 para un consejo!!!

ERECT SOLID WALLS FIRST
CONSTRUYA LOS MUROS SÓLIDOS PRIMERO

See Page 6 for wall #
 Ver la página 6 para # muro.

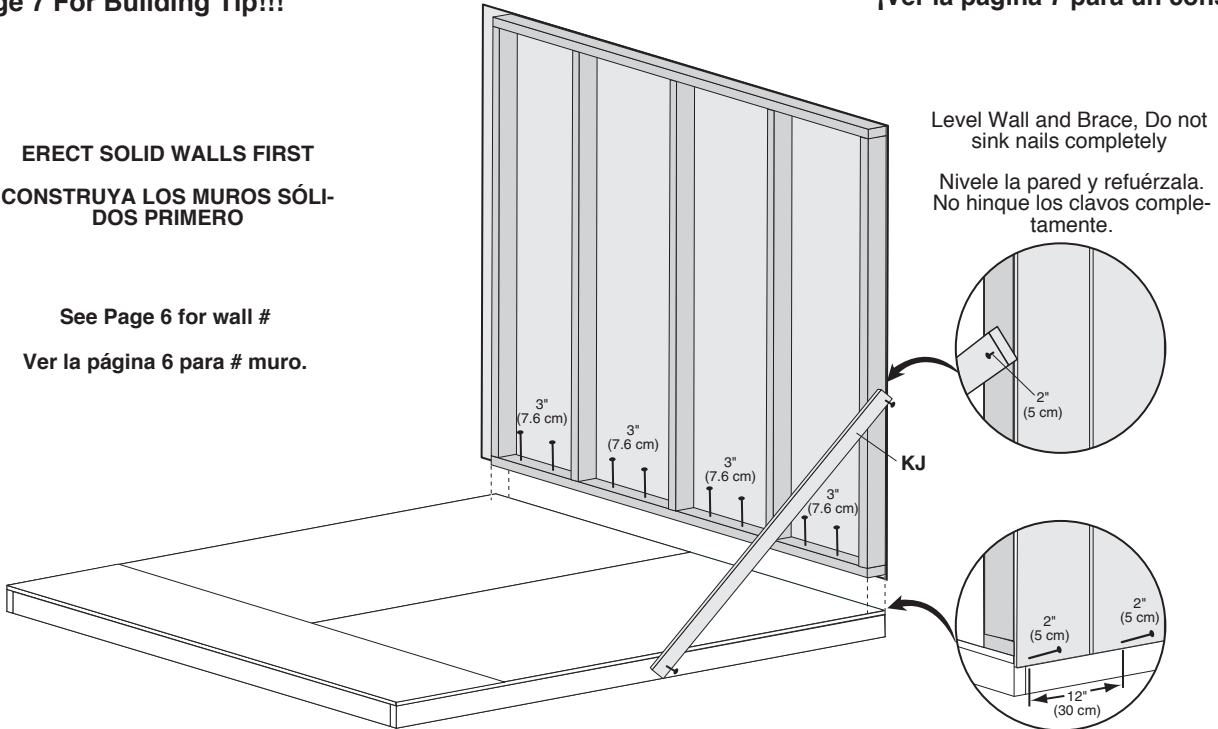

Level Wall and Brace, Do not sink nails completely

Nivele la pared y refuérzala. No hínque los clavos completamente.

ERECTING WALLS

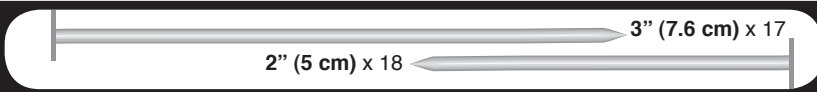

CONSTRUYENDO LOS MUROS

See Page 7 For Building Tip!!!

¡Ver la página 7 para un consejo!!!

See Page 6 for wall #
 Ver la página 6 para # muro.

Level Wall and Nail
 Nivele la pared y clave.

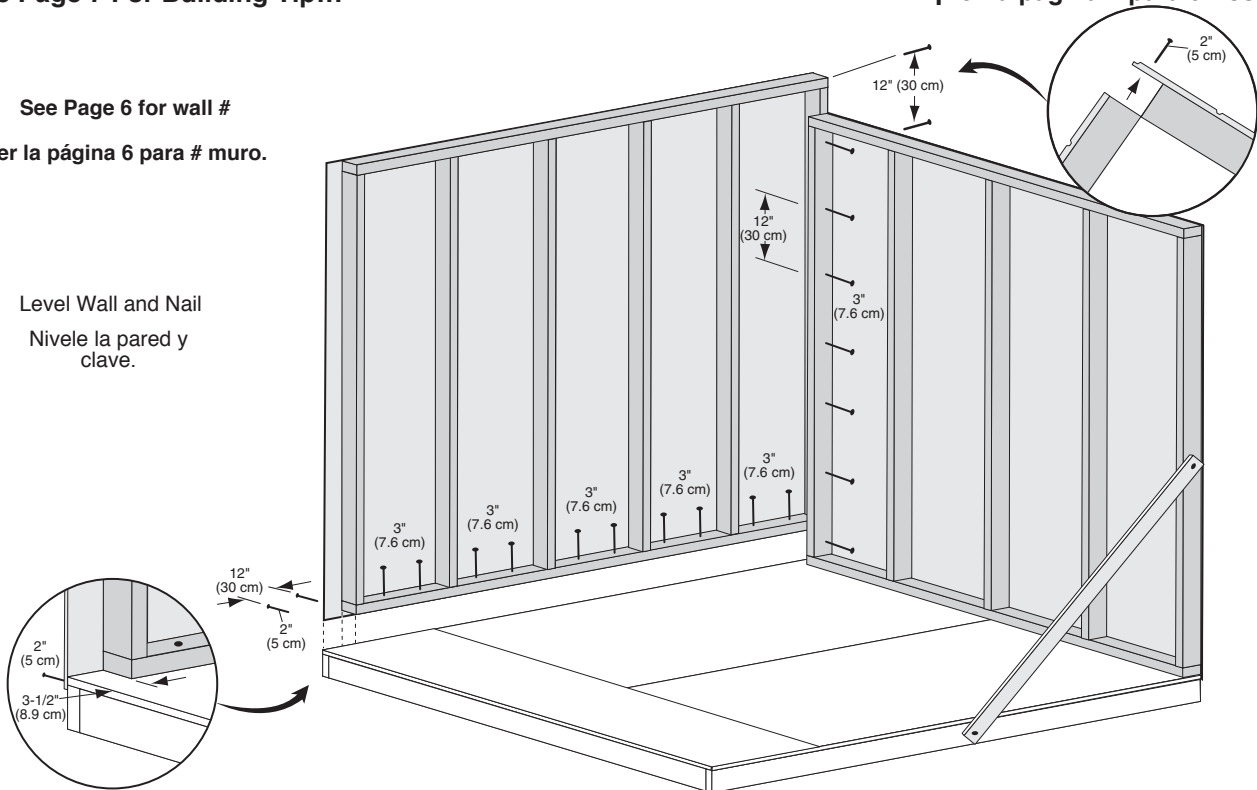

ERECTING WALLS

- 3" (7.6 cm)
- x 15 (10'x8') (305 x 244 cm)
- x 19 (10'x12') (305 x 366 cm)
- x 23 (10'x16') (305 x 488 cm)
- 2" (5 cm)

CONSTRUYENDO LOS MUROS

See Page 7 For Building Tip!!!

¡Ver la página 7 para un consejo!!!

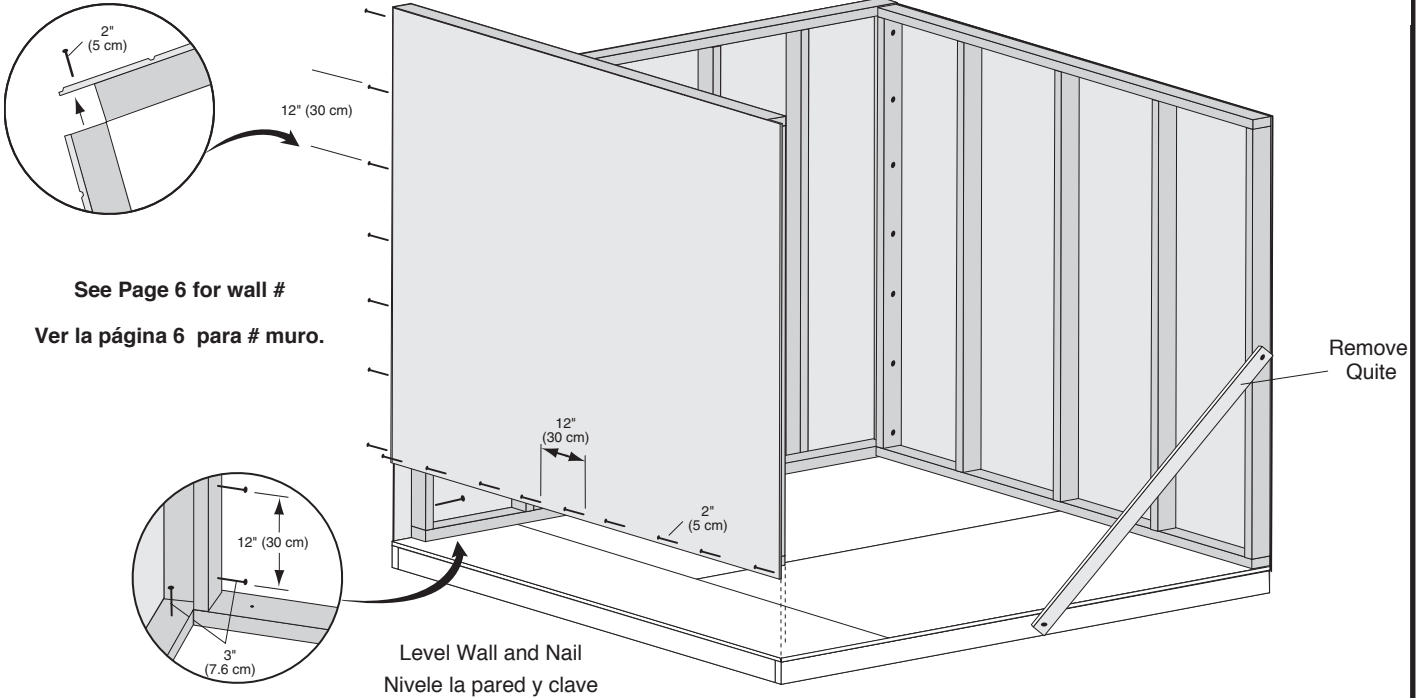

See Page 6 for wall #

Ver la página 6 para # muro.

Level Wall and Nail
Nivele la pared y clave

Remove
Quite

ERECTING WALLS

- 3" (7.6 cm) x 22
- 2" (5 cm) x 22

CONSTRUYENDO LOS MUROS

After walls are erected, make sure X to X and Y to Y measurements are the same

Después de construir los muros, asegúrese que las medidas "X a X" y "Y a Y" son iguales.

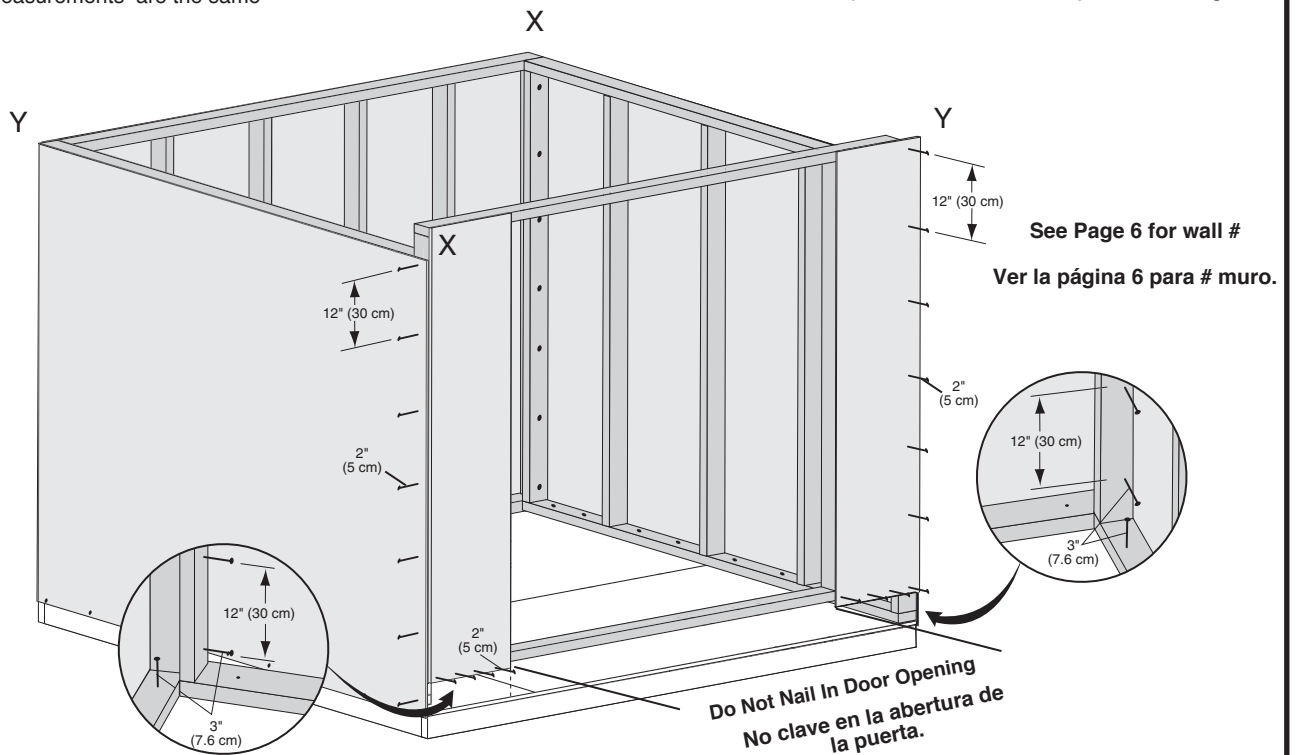

See Page 6 for wall #

Ver la página 6 para # muro.

Do Not Nail In Door Opening
No clave en la abertura de la puerta.

DOUBLERS

3" (7.6 cm)

x 48 (8'x8') (244 x 244 cm)
 x 60 (8'x12') (244 x 366 cm)
 x 72 (8'x16') (244 x 488 cm)

DOBLADORES

10' X 8' (305 x 244 cm)

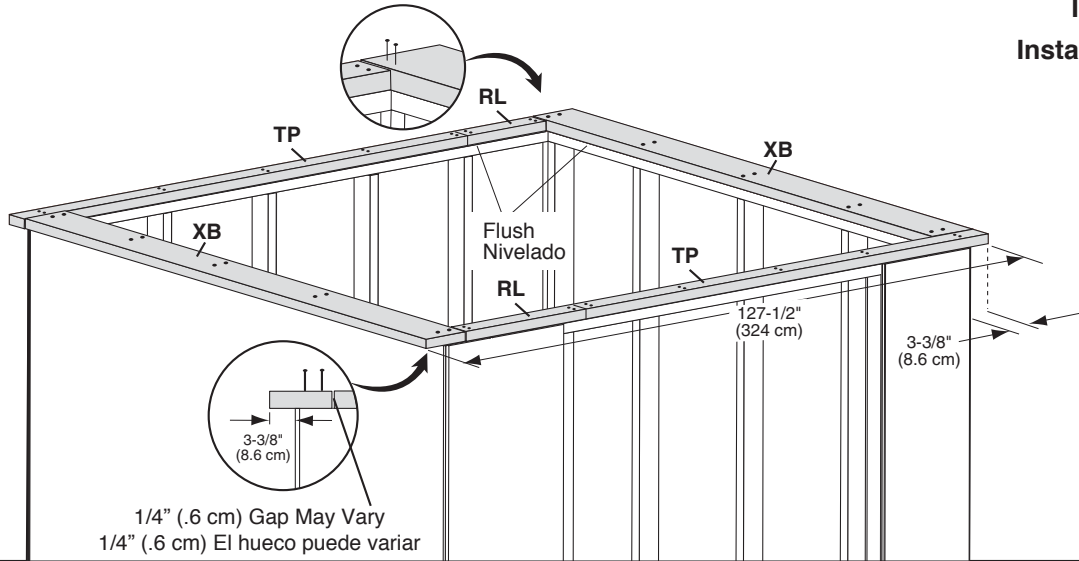

Install as Shown
Instale como en el dibujo

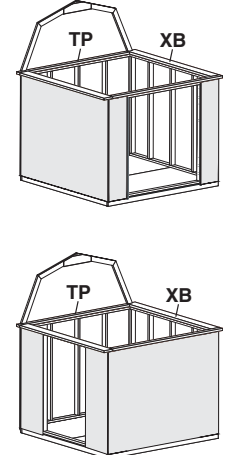

1/4" (.6 cm) Gap May Vary
 1/4" (.6 cm) El hueco puede variar

10' X 12' (305 x 366 cm)

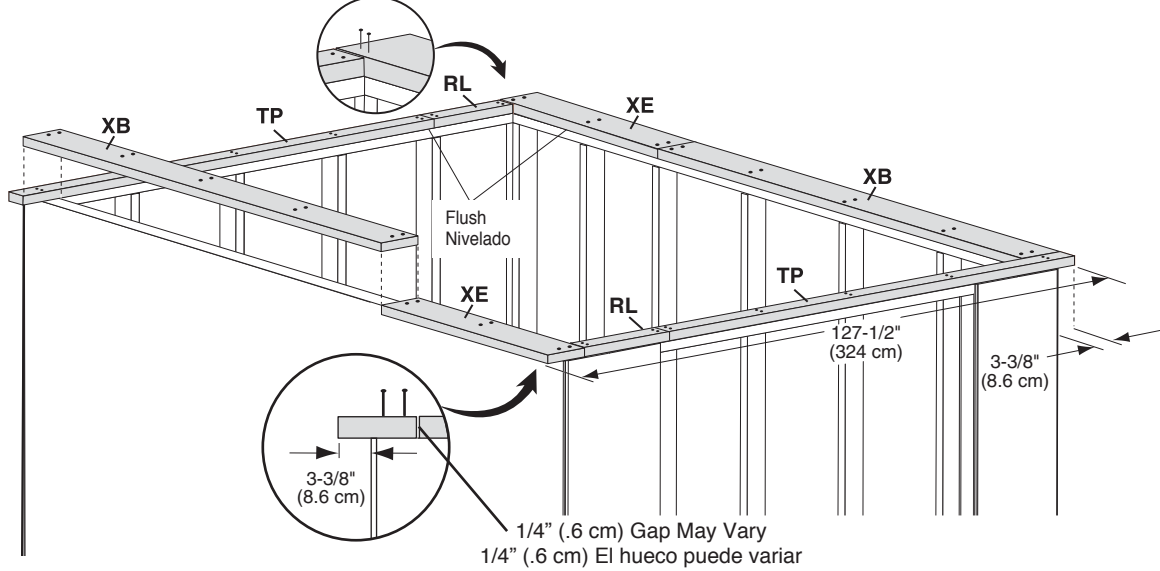

1/4" (.6 cm) Gap May Vary
 1/4" (.6 cm) El hueco puede variar

10' X 16' (305 x 488 cm)

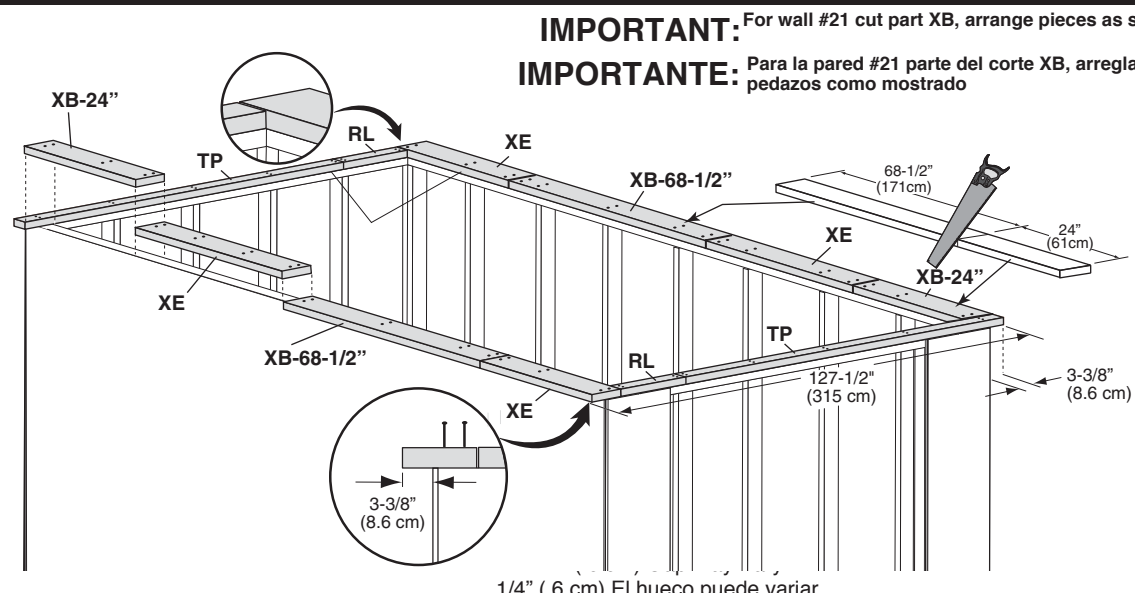

1/4" (.6 cm) El hueco puede variar

IMPORTANT: For wall #21 cut part XB, arrange pieces as shown
IMPORTANTE: Para la pared #21 parte del corte XB, arregla los pedazos como mostrado

ROOF

1-1/2"(3.8 cm)

x 12

TECHO

End Rafter Assembly x2

Conjunto de vigas terminales x2

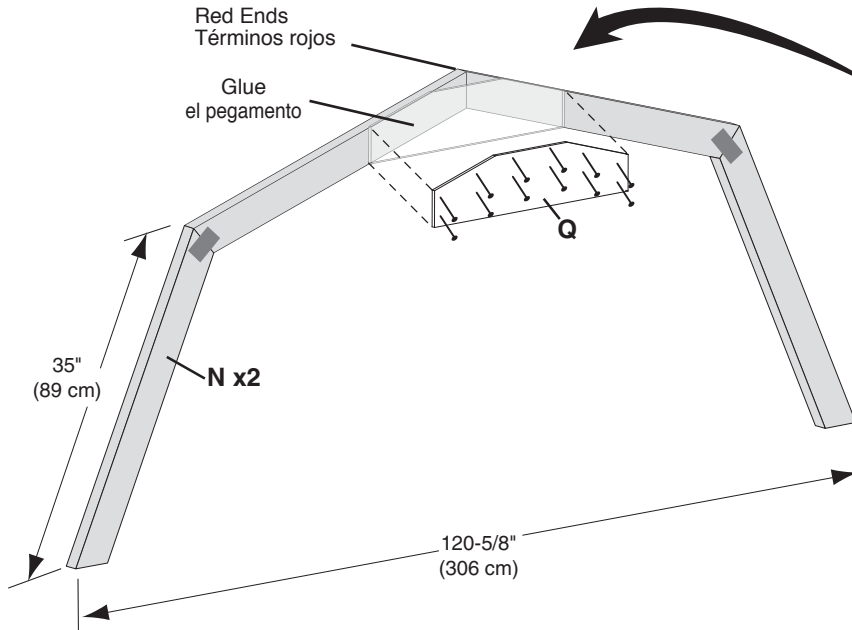

x2

ROOF

1-1/2"(3.8 cm)

x 24

3"(7.6 cm)

x 8

TECHO

**Middle Rafter Assembly
(See sizes below for quantity)**

**Conjunto de vigas centrales
(Ver las dimensiones abajo para la cantidad)**

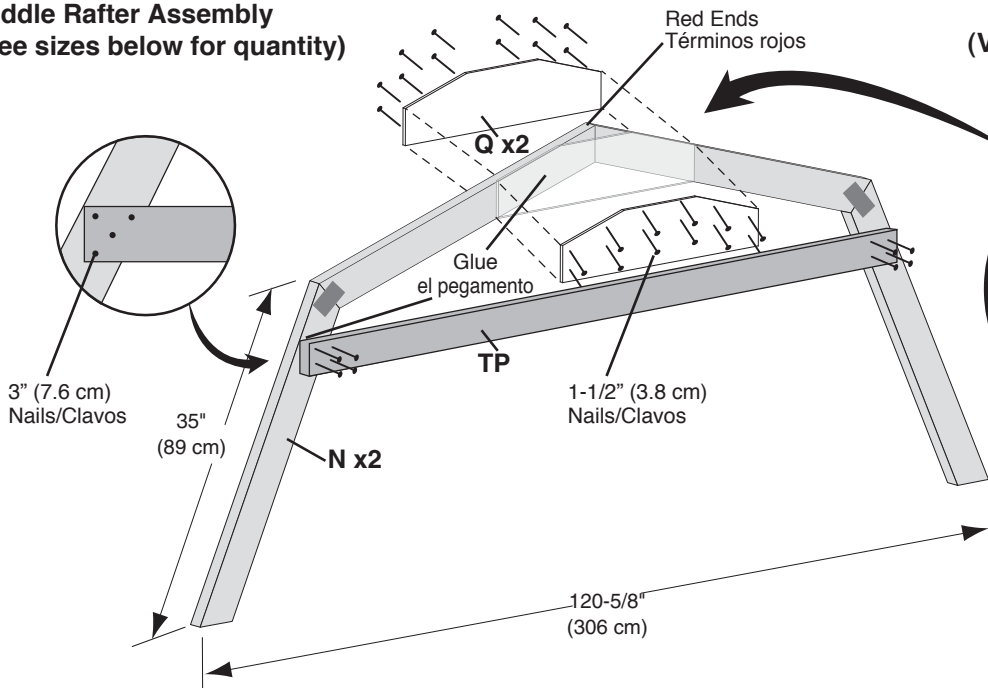

10'x8' (305 x 244 cm)

10'x12' (305 x 366 cm)

10'x16' (305 x 488 cm)

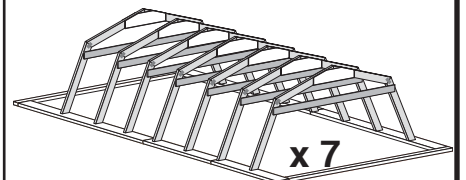
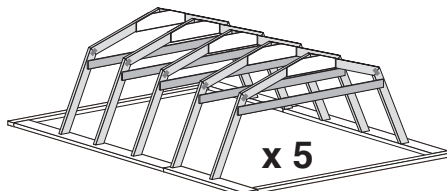
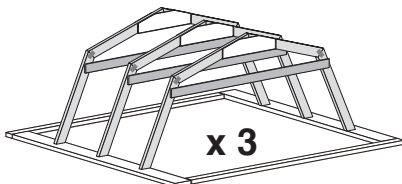

ROOF

TECHO

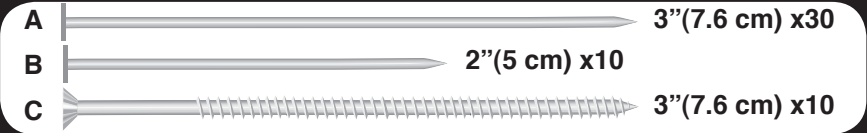

Attaching Rafters and Soffit Blocks
 (See below for dimensions)

Fijando las vigas y los bloques del sofito.
 (Ver abajo para las dimensiones.)

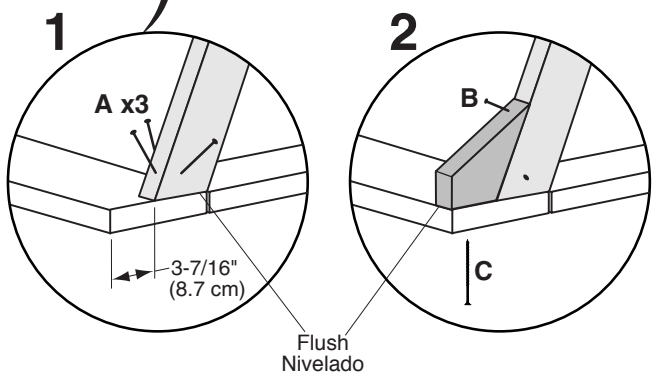
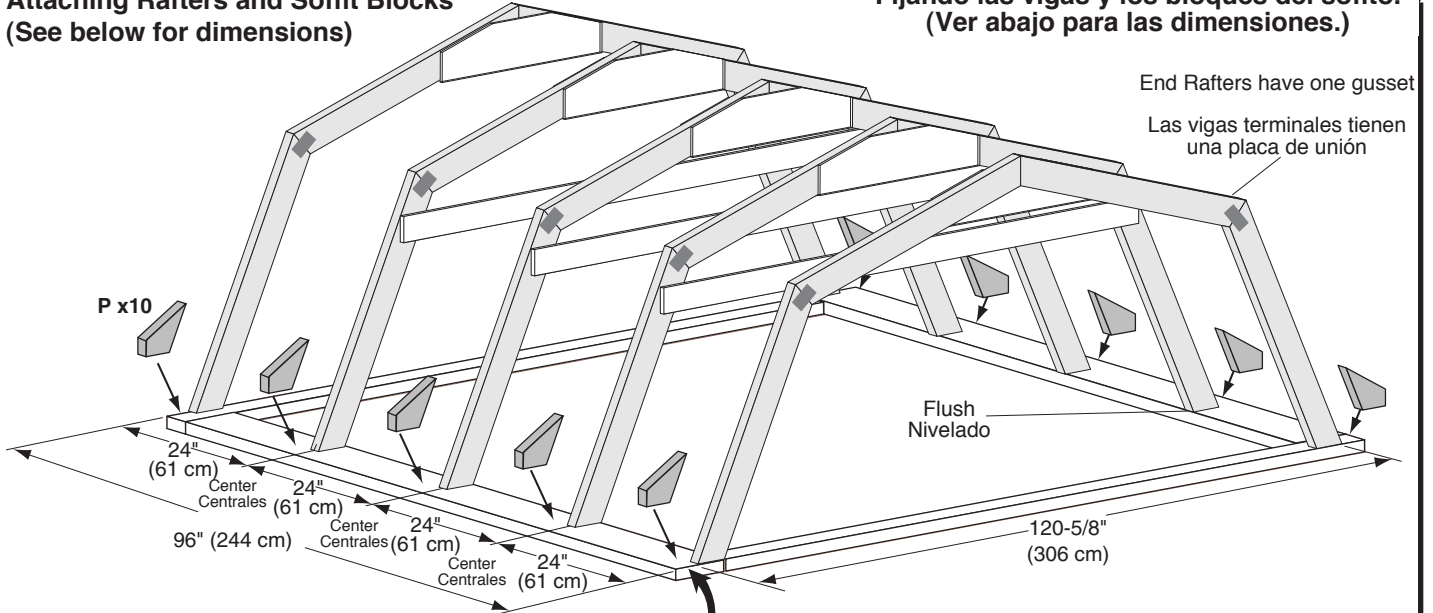

10'x8' (305 x 244 cm) Shown / Indicado

10'x12' (305 x 366 cm)

10'x16' (305 x 488 cm)

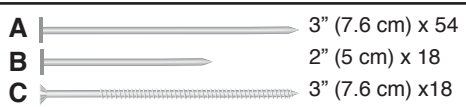
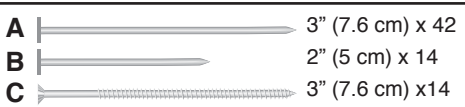
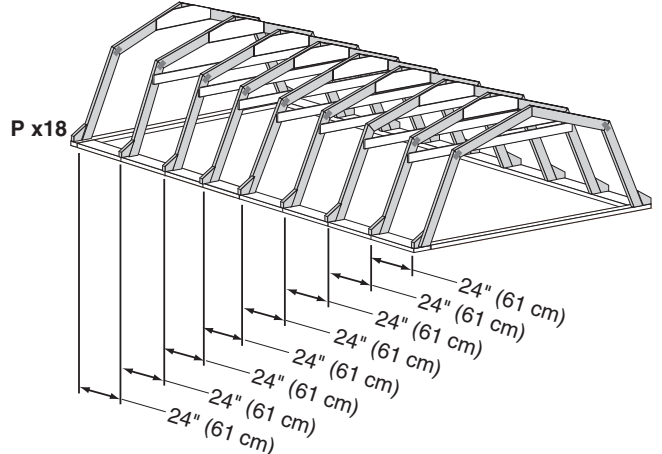
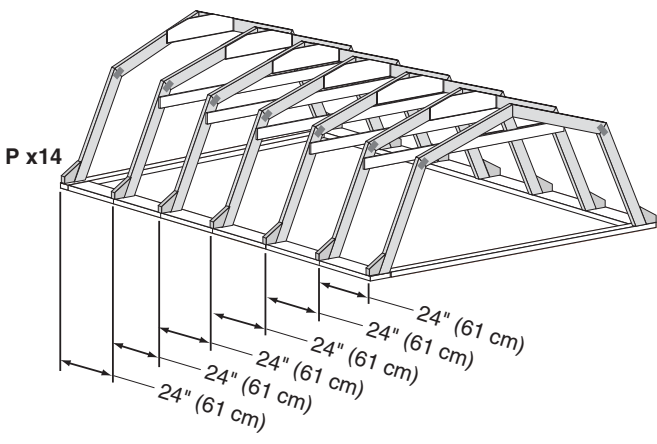

ROOF

2"(5 cm)

x110

TECHO

See Page 8 For Building Tip!!!

¡Ver la página 8 para un consejo!!!

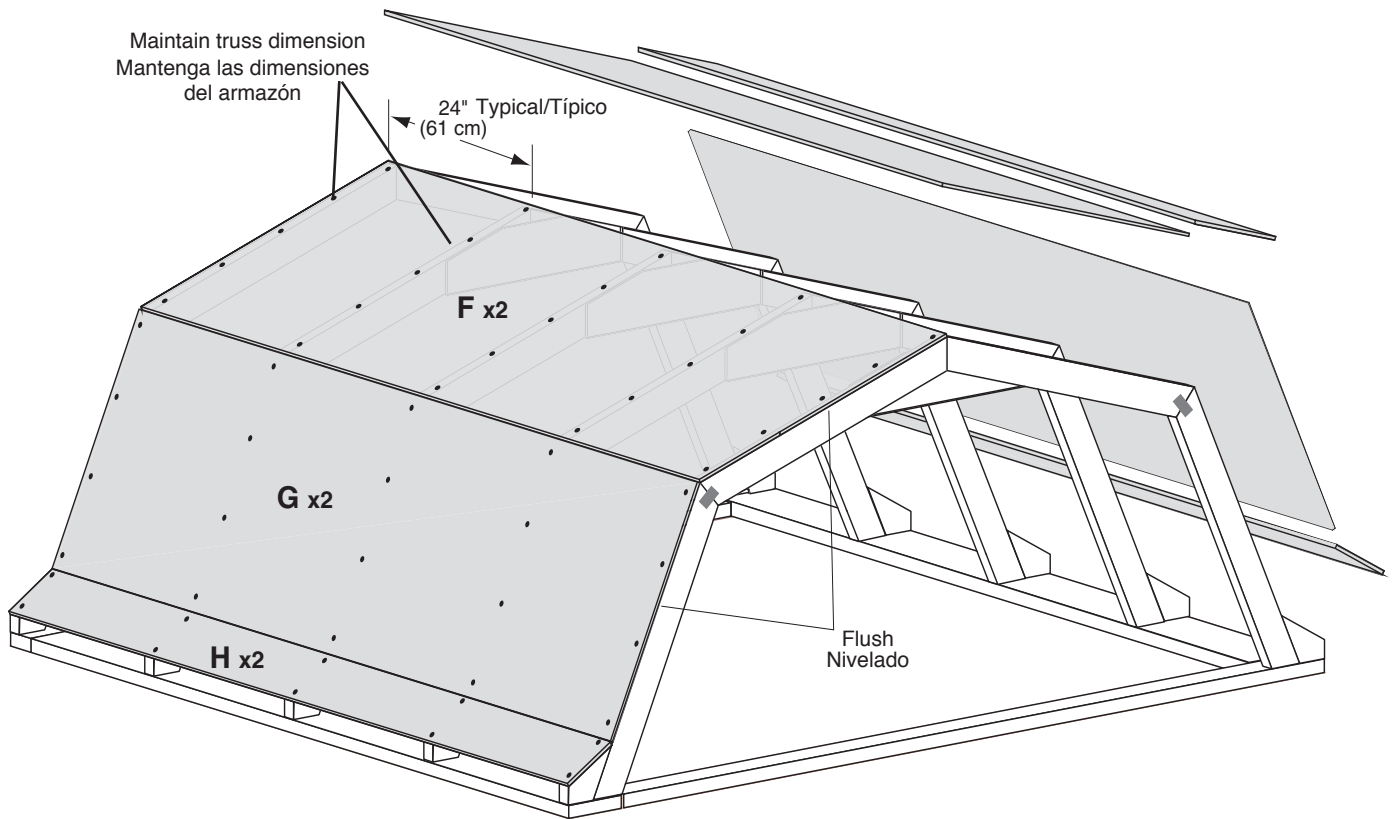

10'x8' (305 x 244 cm) Shown / Indicado

10'x12' (305 x 366 cm)

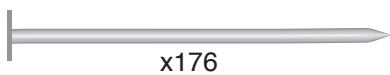
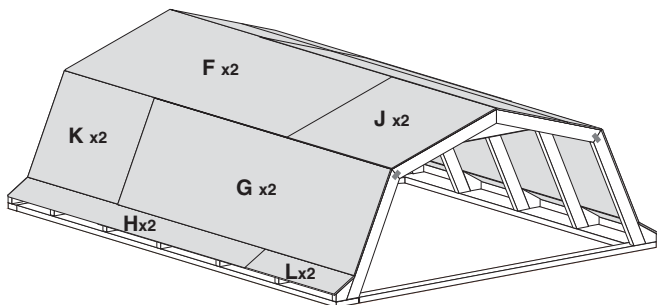

10'x16' (305 x 488cm)

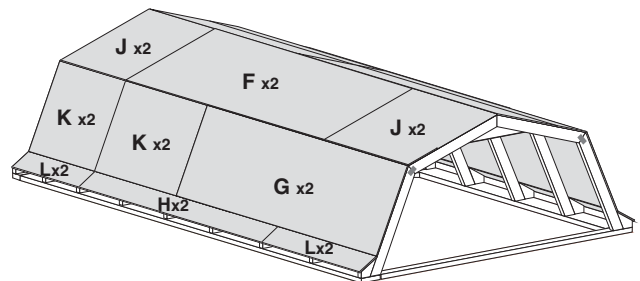

ROOF

1-1/2" (3.8 cm)

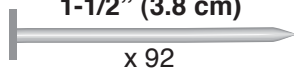

x 92

TECHO

Gable Panels

Paneles del techo a dos aguas

DRY FIT PANELS AS SHOWN HERE BEFORE ASSEMBLING

Los paneles montan según lo visto

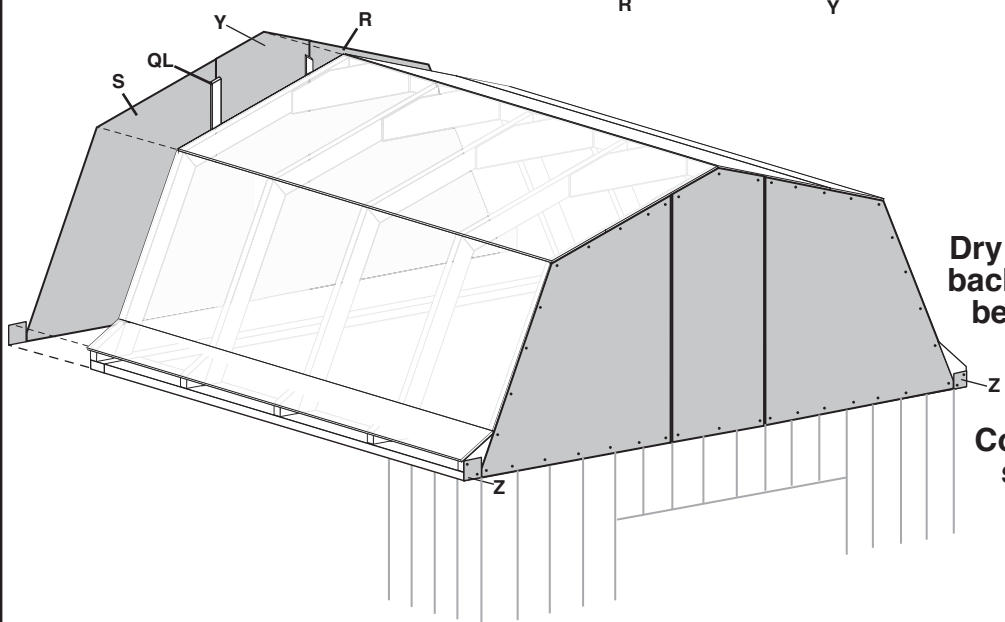
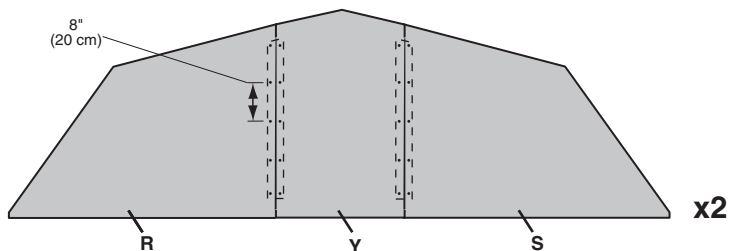
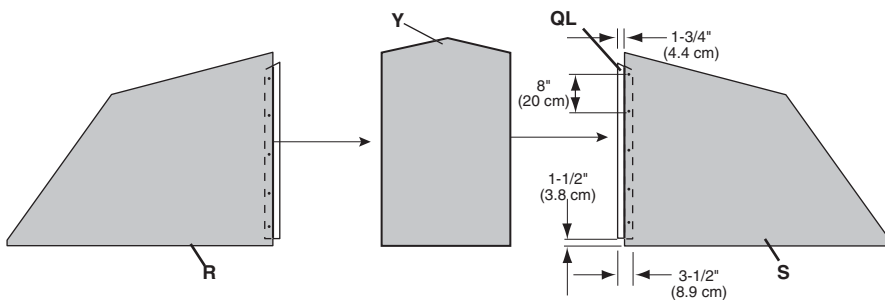
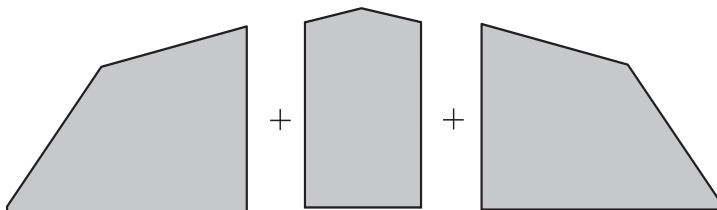

Dry fit assembly on front and back of building to determine best alignment of grooves

Compruebe la alineación del surco en frente y la parte posterior

TRIM

2"(5 cm)

x 150

3/4"(1.9 cm)

x 6

MOLDURA

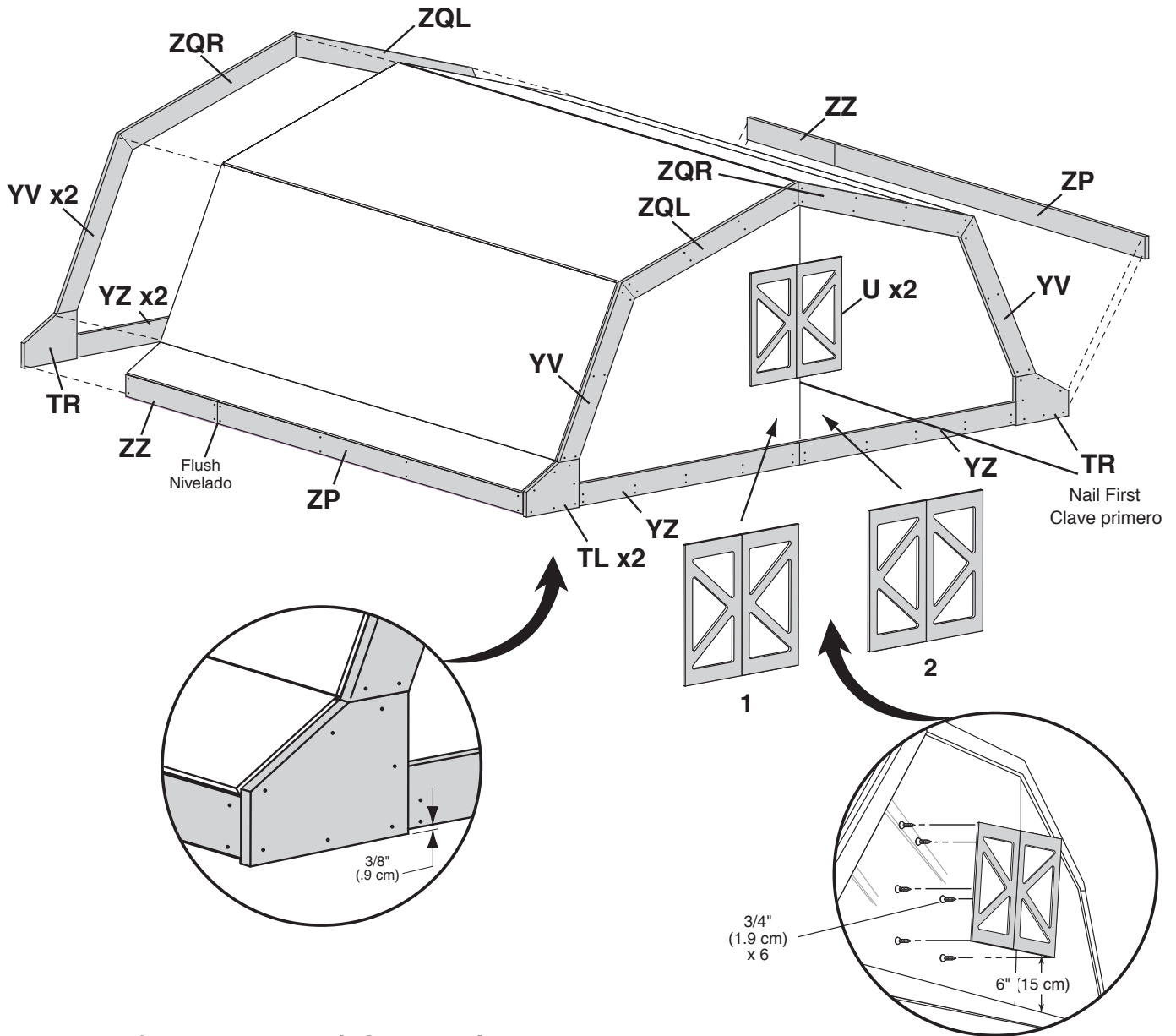

10'x8' (305 x 244 cm) Shown / Indicado

10'x12' (305 x 366cm)

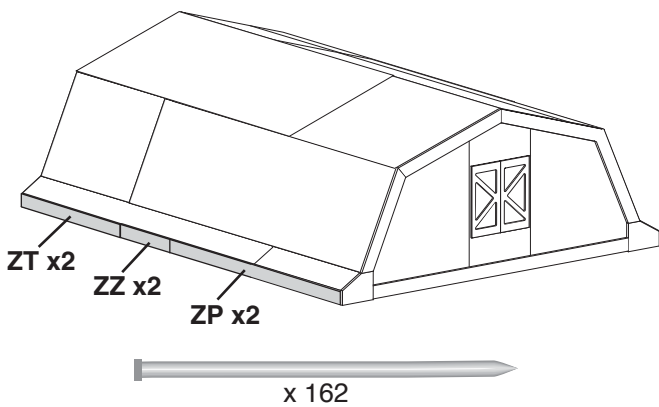

10'x16' (305 x 488 cm)

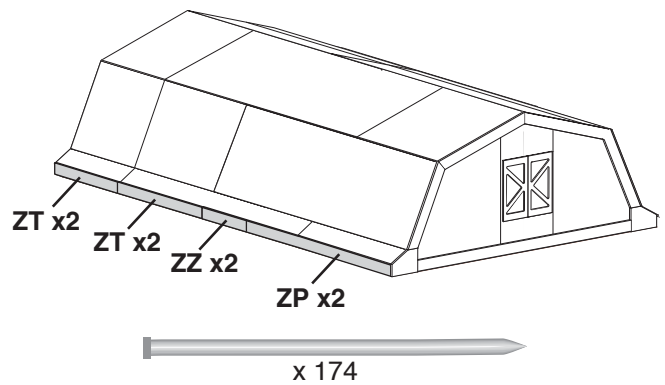

DOOR

1-5/8" (4.1 cm)



PUERTA

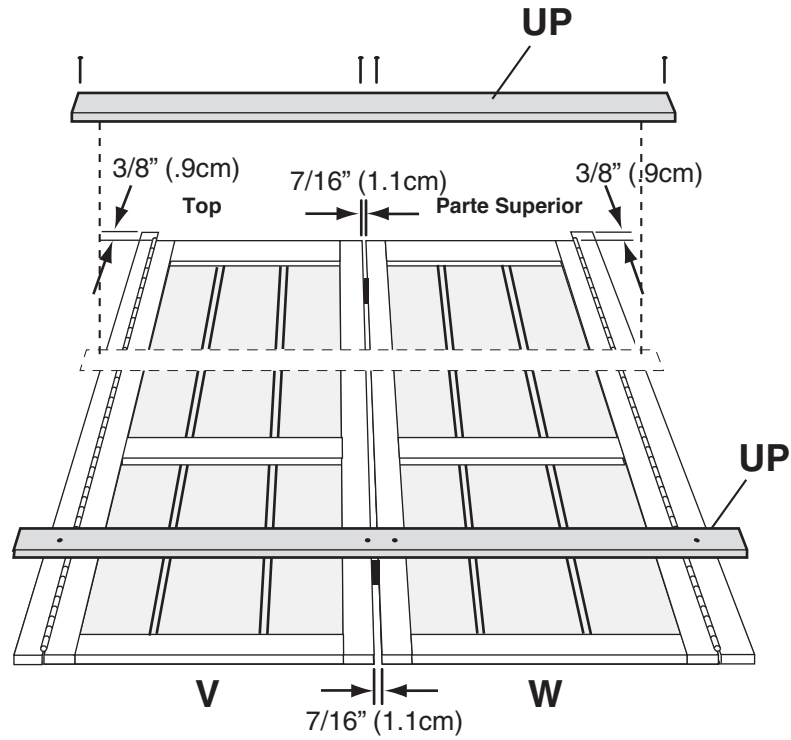

DOOR

PUERTA

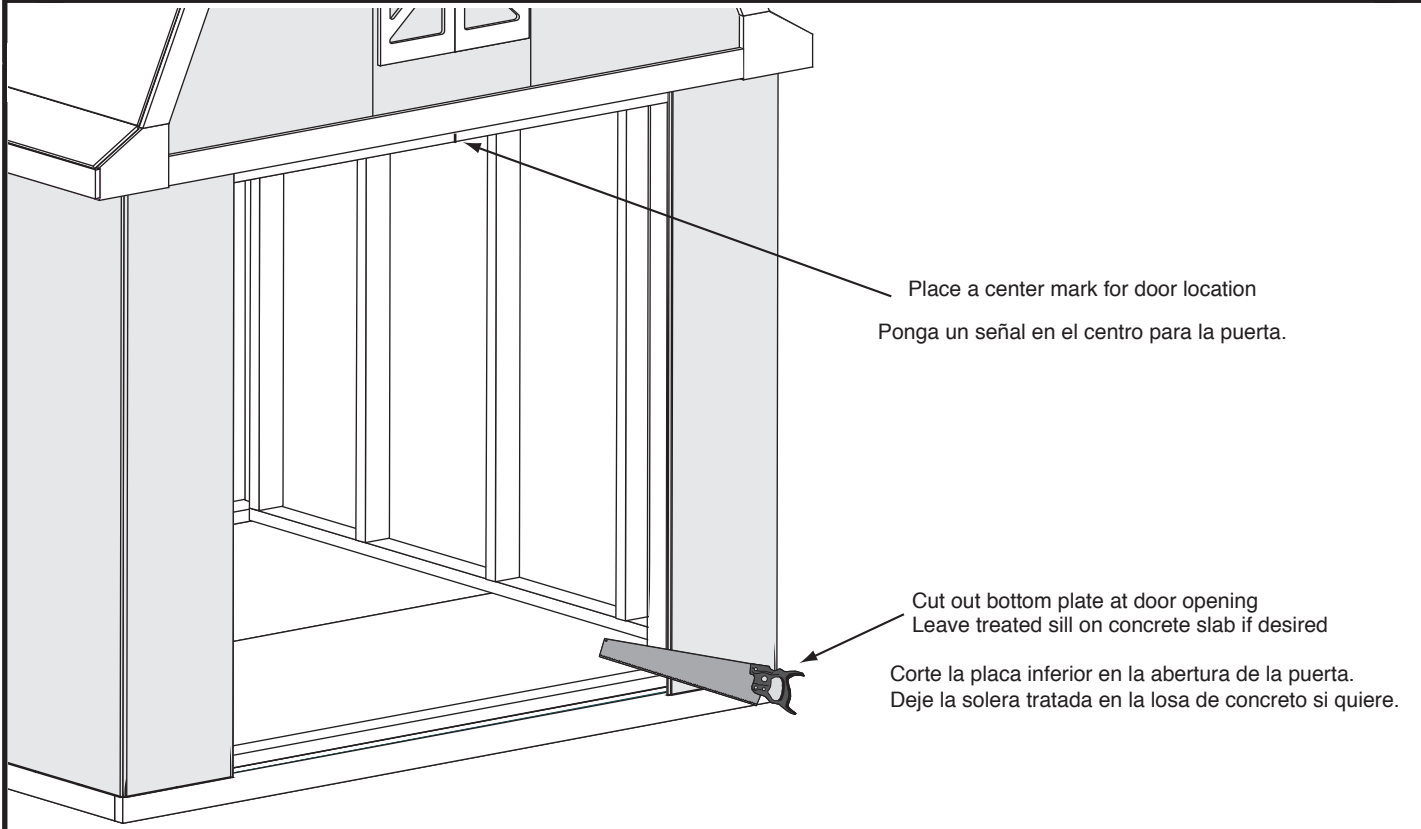

DOOR

A
B

3" (7.6 cm) x 6

2" (5 cm) x 8

C 1" (2.5 cm) x 12

PUERTA

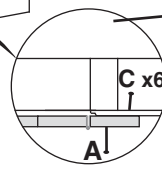
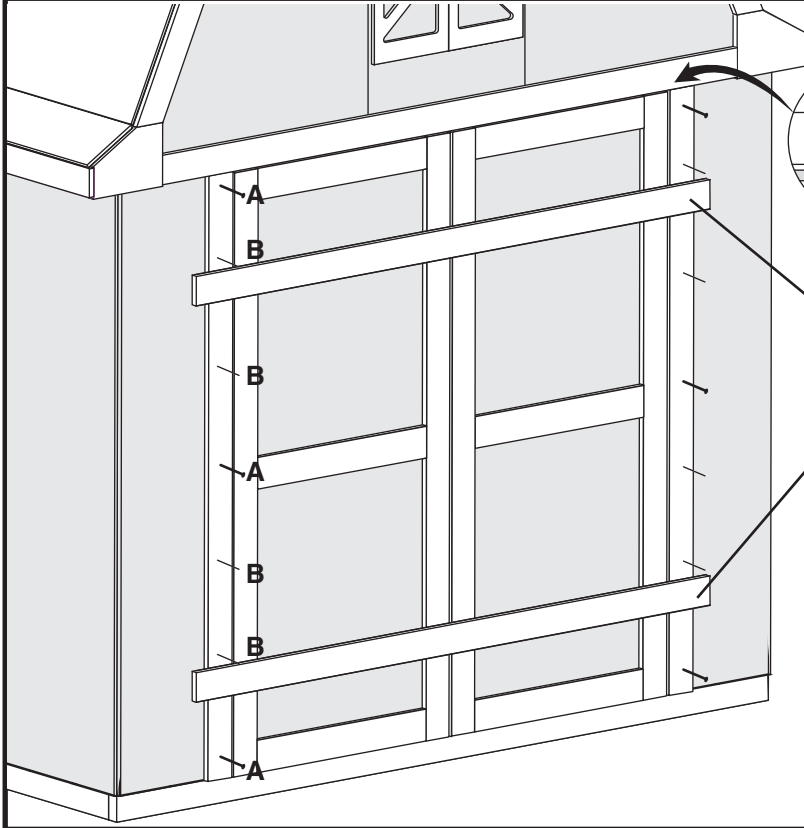

Inside Building
Interior del edificio

Attach with 3" (7.6 cm) Screws first, remove X and Y, check doors to open properly and nail

Fije con tornillos de 3" (7.6 cm) primero, quite X y Y, compruebe que las puertas abren bien y clave.

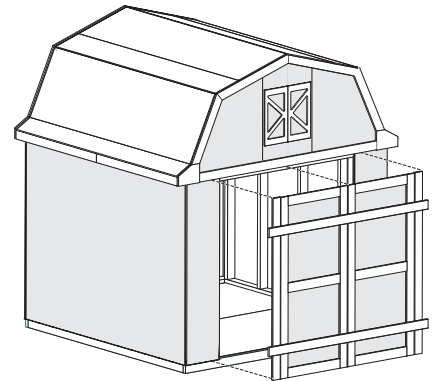

TRIM

2" (5 cm)

x 72

MOLDURA

Do not sink nails completely.
No hínque los clavos completamente.

12" (30 cm)

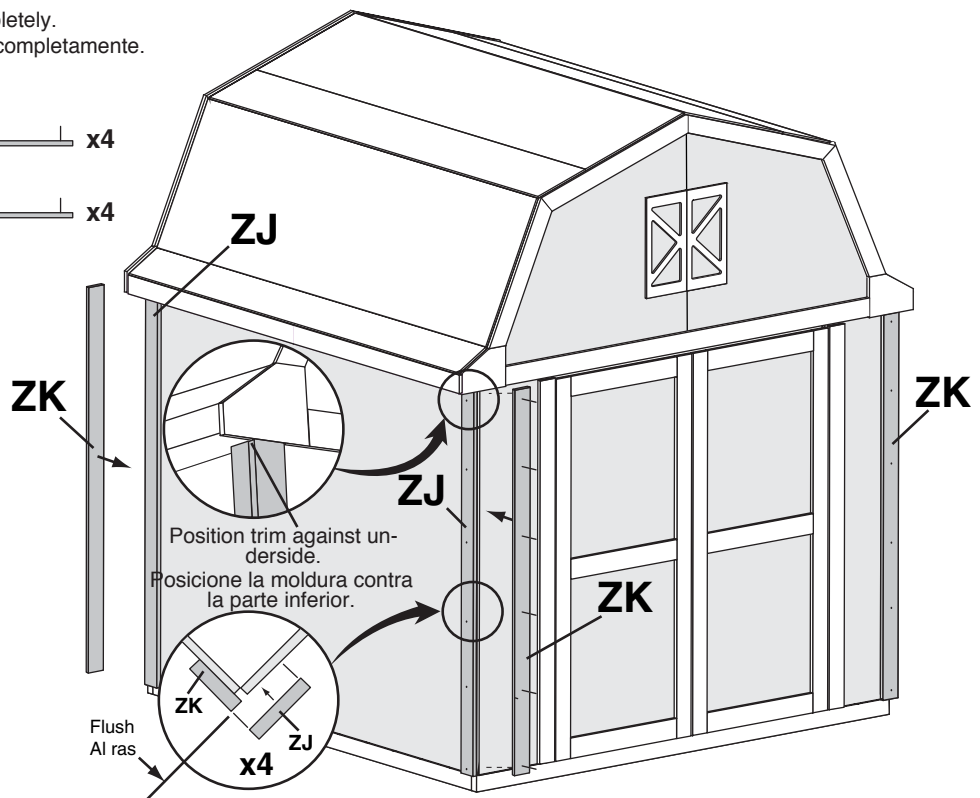
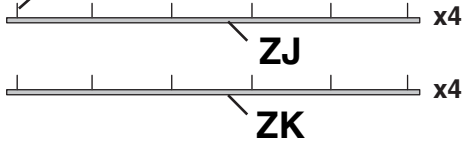

Position trim against underside.
Posicione la moldura contra la parte inferior.

Flush
Al ras

DOOR

PUERTA

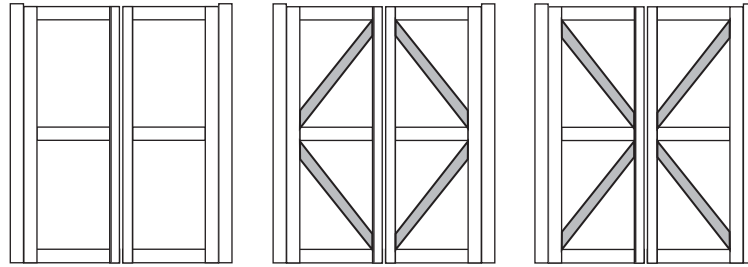
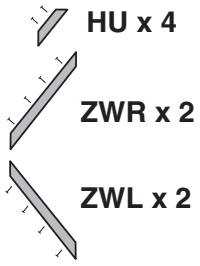

Plain

Diamond

Traditional X

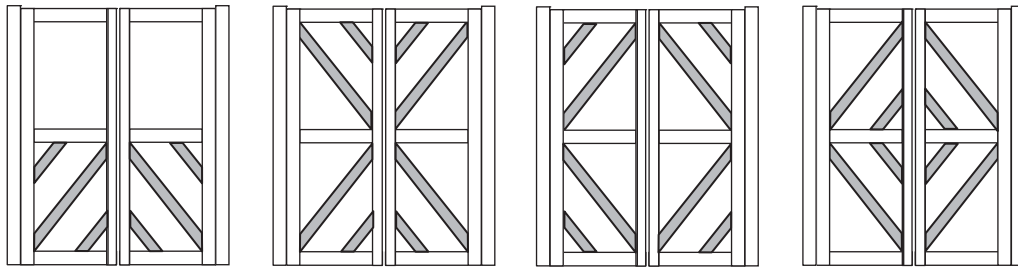

Contemporary

Double X

Outer Diamond

Inner Diamond

DOOR

PUERTA

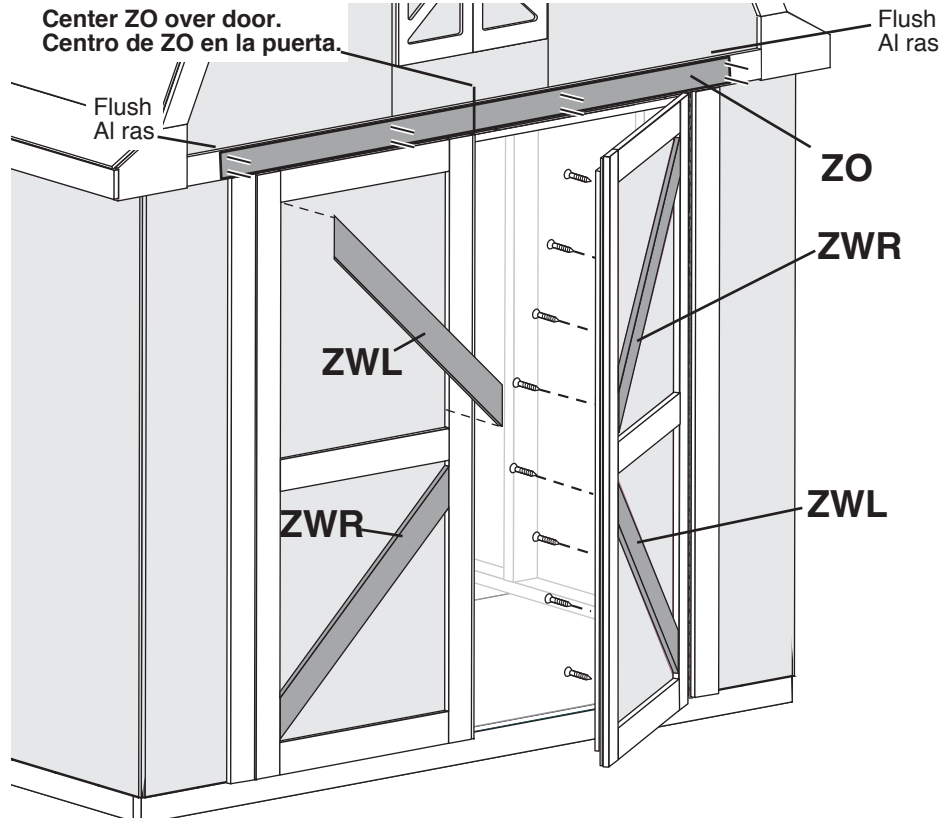
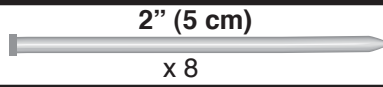
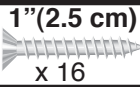

DOOR

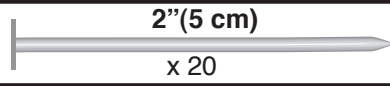
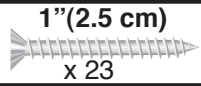

PUERTA

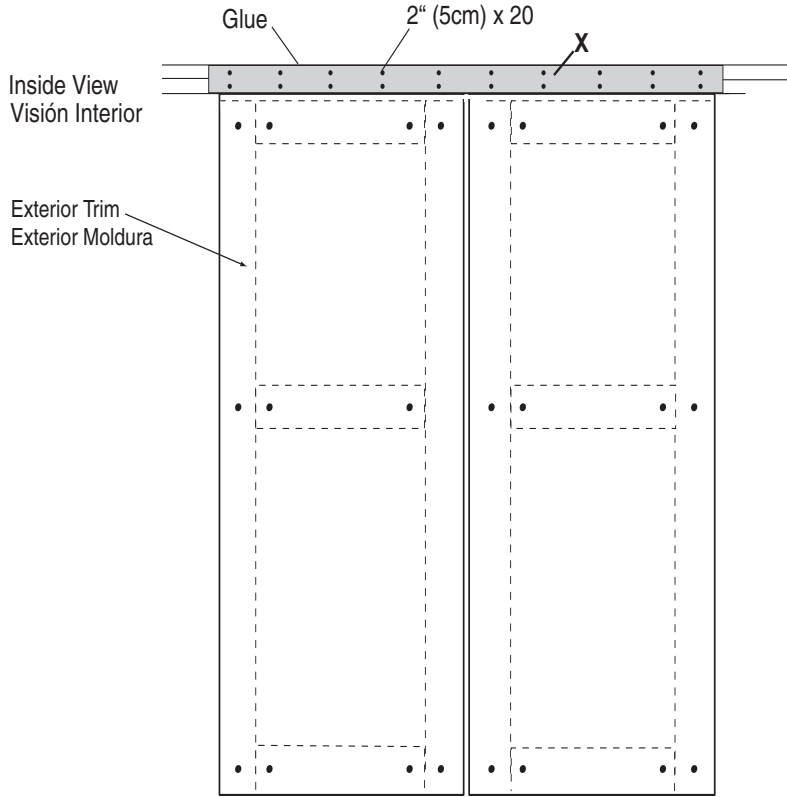

DOOR



PUERTA

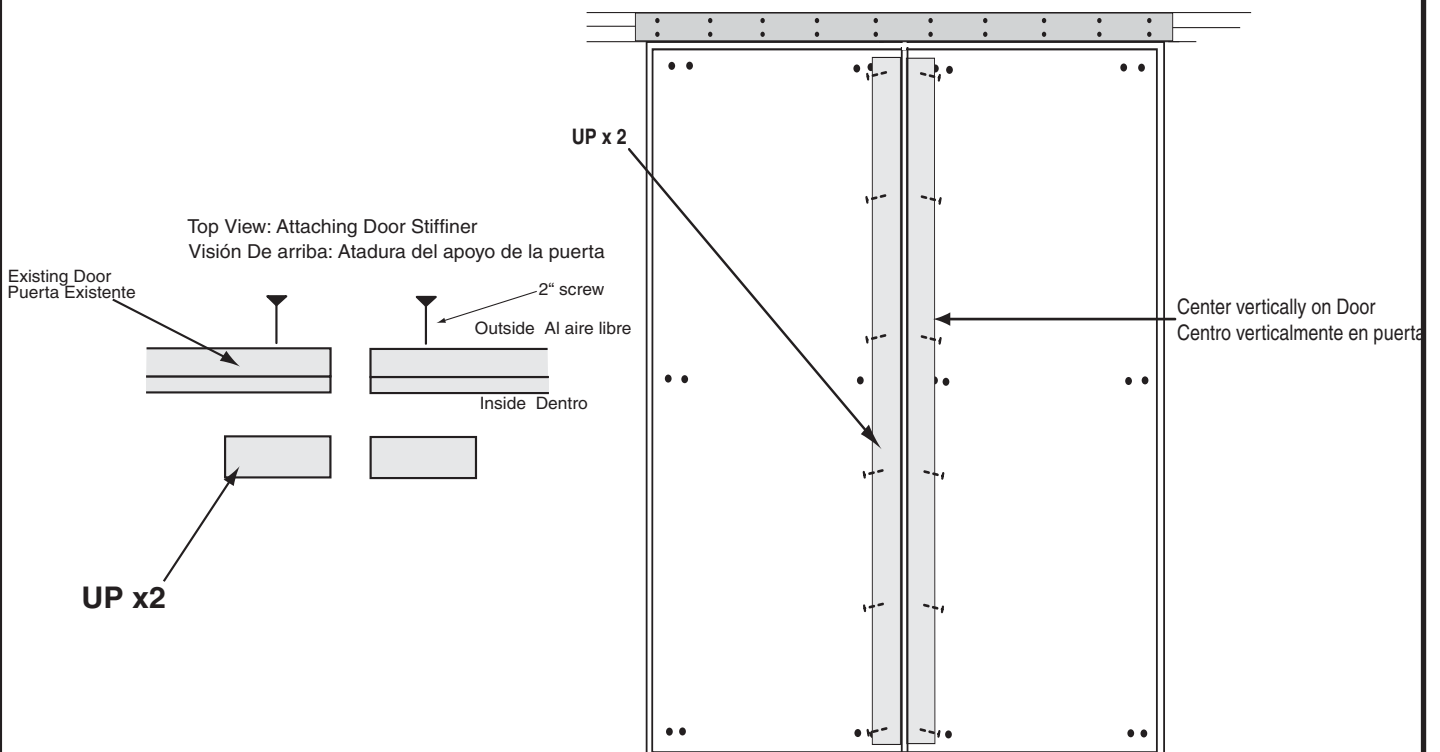

DOOR

1"(2.5 cm)
x 34

PUERTA

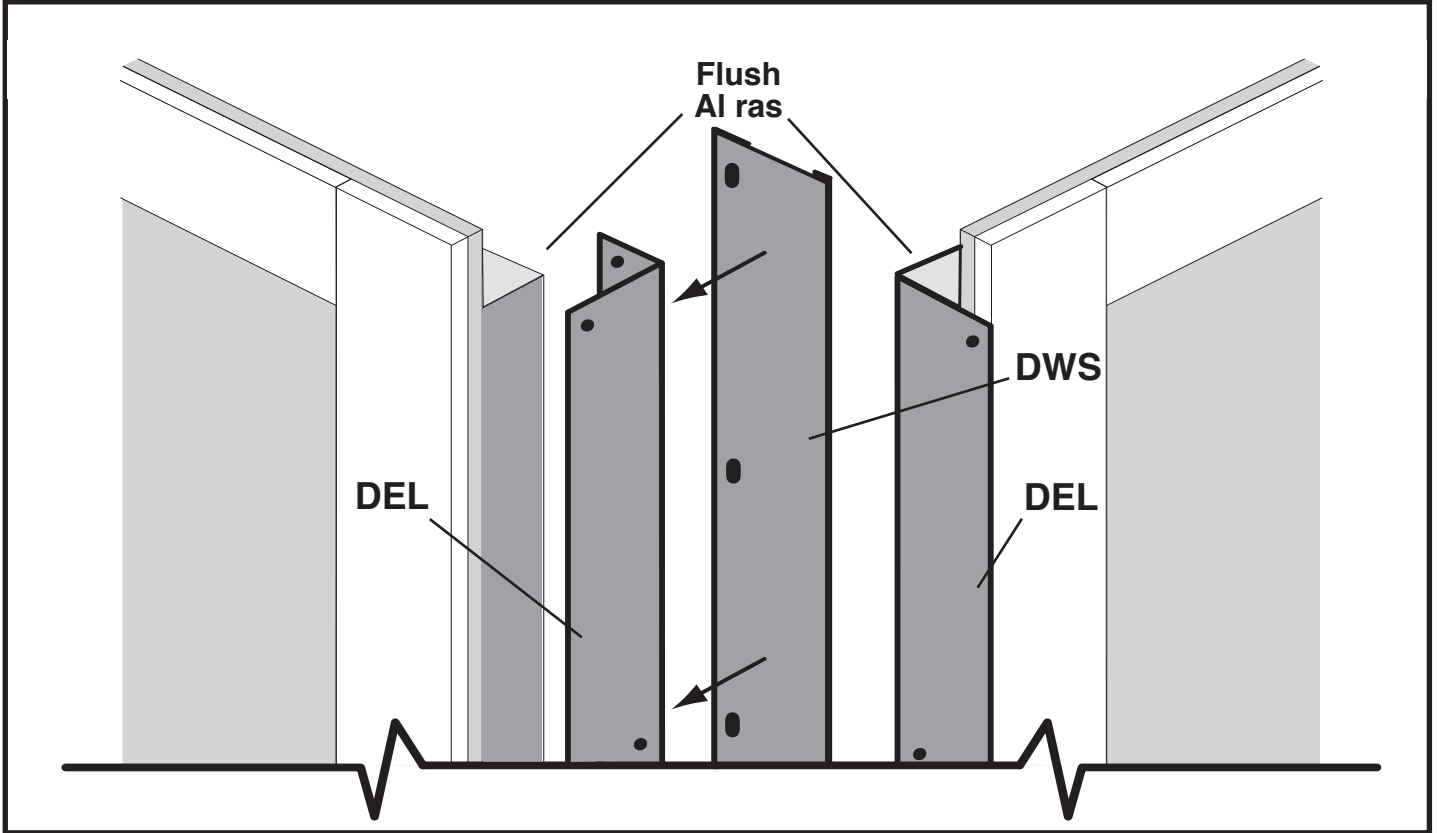

DOOR HANDLE

TIRADOR

1

2

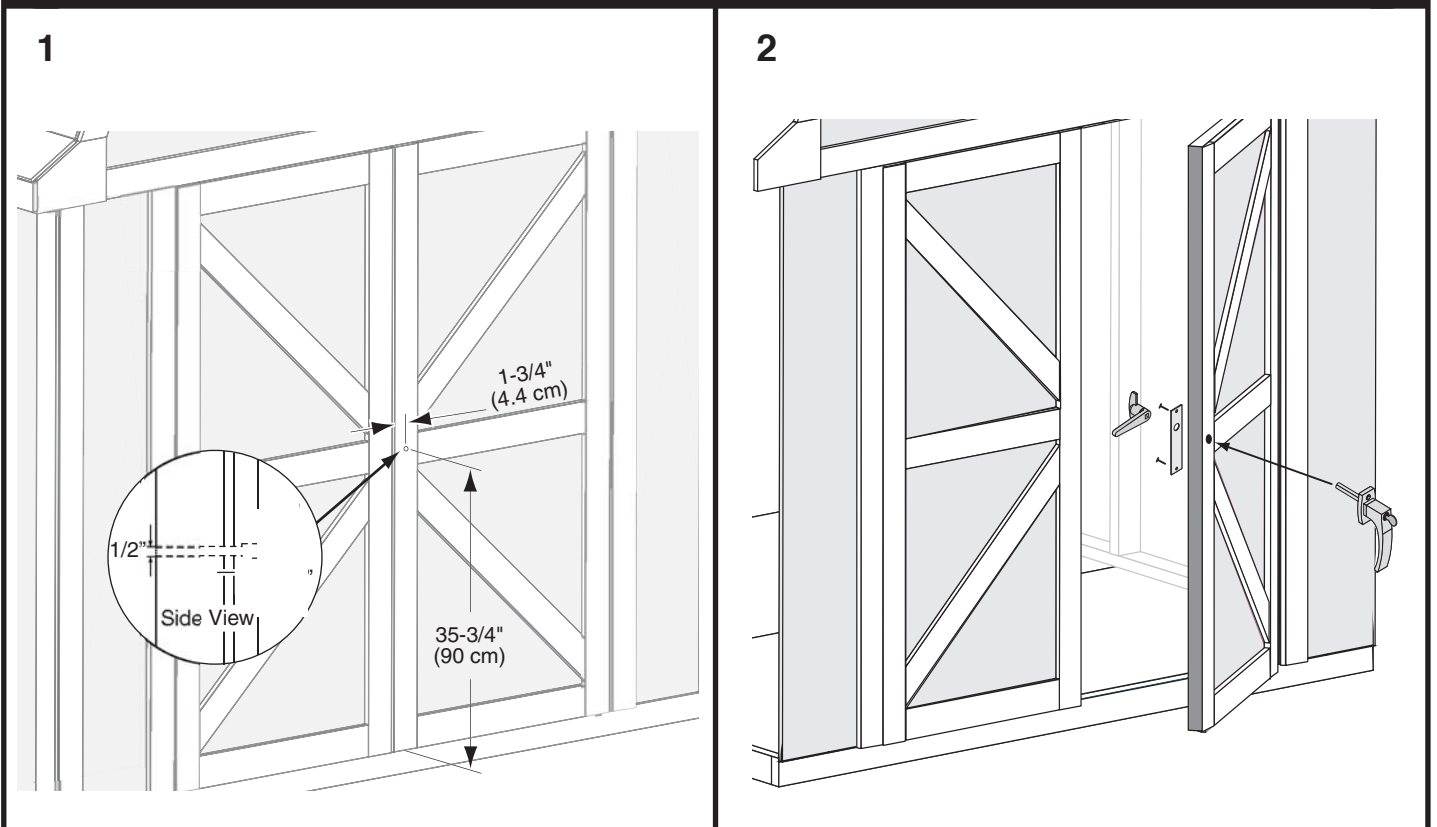

HOOK AND EYE AND BARREL BOLT

ENGANCHE Y el OJO Y el BARRIL CIERRAN

Select Desired location for your Hook and Eye.

Seleccione la posición para el corchete

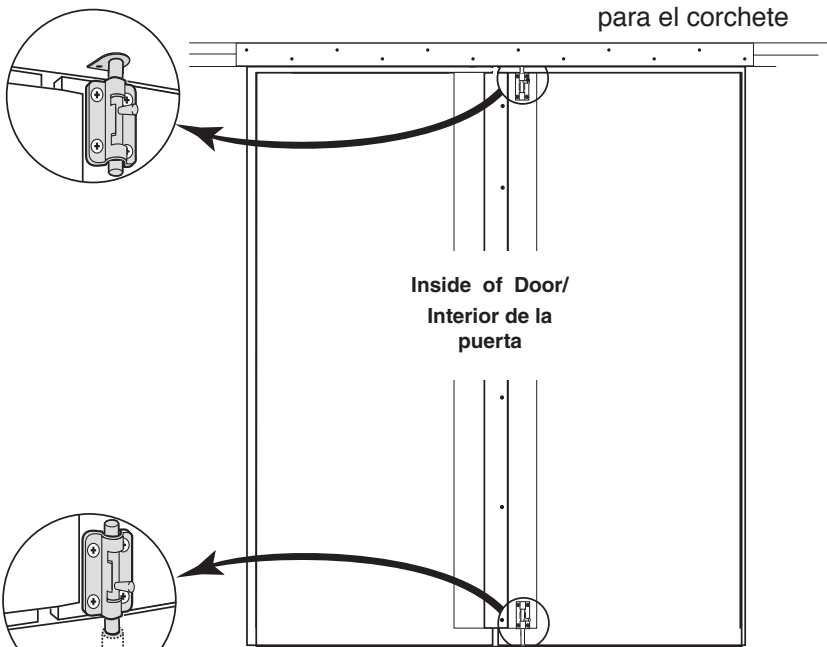

Drill hole 1/2" (1.3 cm) deep using 3/8" (.95 cm) bit

NOTE: Install hook and eye into trim or stud.

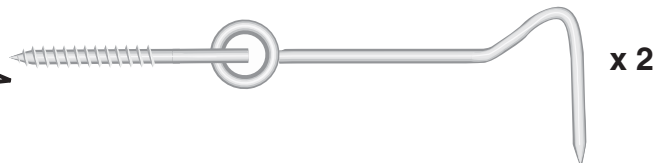
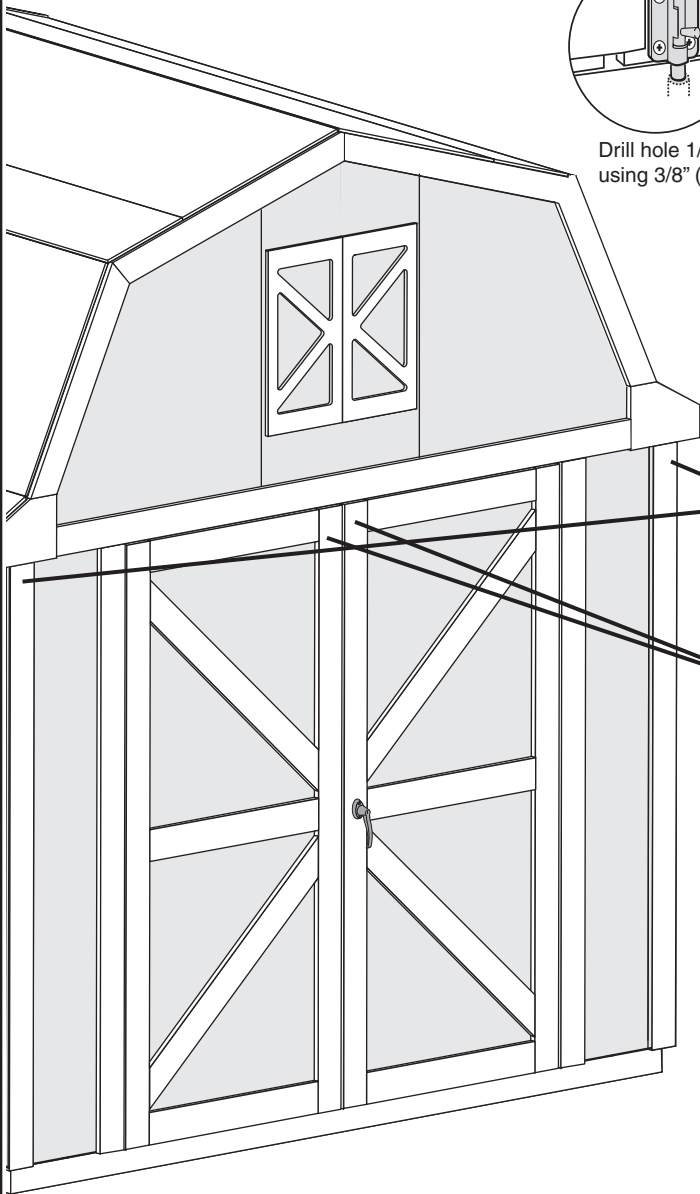

Hooks must go into trim or a stud

Hay que fijar los corchetes a la moldura o un montante

PAINT AND CAULK (Not Included)

Use Acrylic Latex Caulk that is paintable. Caulk at all horizontal and vertical seams, between the Trim and Walls, and all around the Door Trim.

Use a high quality exterior acrylic latex paint. When painting your building, there are a few key areas that can be easily overlooked that **must** be painted:

- Bottom edge of all siding and trim
- Inside of doors and all 4 edges

Note: Prime all un-primed exterior wood before painting

PINTURA Y MASILLADO (No Incluidas)

Use un masillado acrílico de latex que se puede pintar. Masille todas las juntas horizontales y verticales, entre la moldura y los muros, y alrededor de la moldura de la puerta.

Use una pintura acrílica de latex de alta calidad. Al pintar su edificio, hay unas areas claves que hay que pintar:

- El borde inferior de toda la cobertura y la moldura.
 - El interior de la puerta y todos los 4 bordes de ésta.
- Aviso: Ponga un imprimador en la madera exterior que no lo tiene antes de pintar.

Building Size Dimensiones del edificio	Building Paint Pintura del edificio	Trim Paint Pintura de moldura	Caulk Masillado
10' x 8' (305 x 244 cm)	2 Gallons/ galones	1 Quart/cuartas	2 Tubes/Tubos
10' x 12' (305 x 366 cm)	2-1/2 Gallons/ galones	1 Quart/cuartas	2 Tubes/Tubos
10' x 16' (305 x 488 cm)	3 Gallons/ galones	1 Quart/cuartas	2 Tubes/Tubos

DRIP EDGE (Not Included)

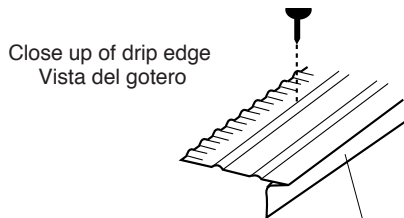

Close up of drip edge
Vista del gotero

Side that hangs over
side No Nails
La parte que está col-
gada sobre un lado.
No clavar.

GOTERO DE BORDE (No Incluidas)

Snip bottom side of drip edge and
Bend over to other side of Roof

Corte la parte inferior del gotero y
dóblela sobre el otro lado del techo

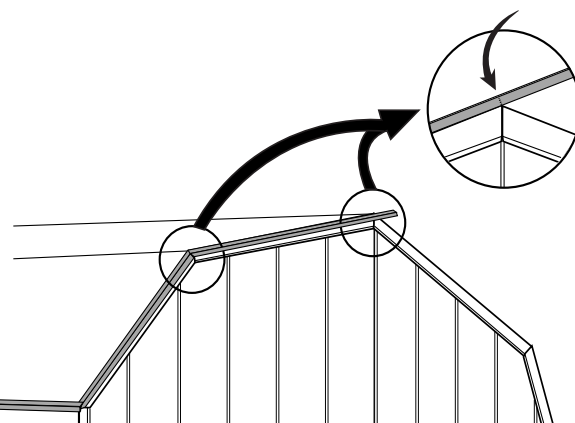

Building Size Dimensiones del edificio	Drip edge Gotero de borde
10' x 8' (305 x 244 cm)	50 feet/pies
10' x 12' (305 x 366 cm)	60 feet/pies
10' x 16' (305 x 488 cm)	70 feet/pies

SHINGLES (Not Included)

Building Size Dimensiones del edificio	Shingles Needed Tejas Necesarias
10' x 8' (305 x 244 cm)	5 Bundles/bultos
10' x 12' (305 x 366 cm)	7 Bundles/bultos
10' x 16' (305 x 488 cm)	9 Bundles/bultos

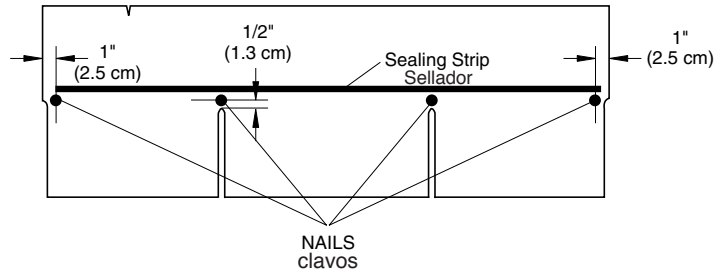

Install first row backwards
Instale la primera fila al revés

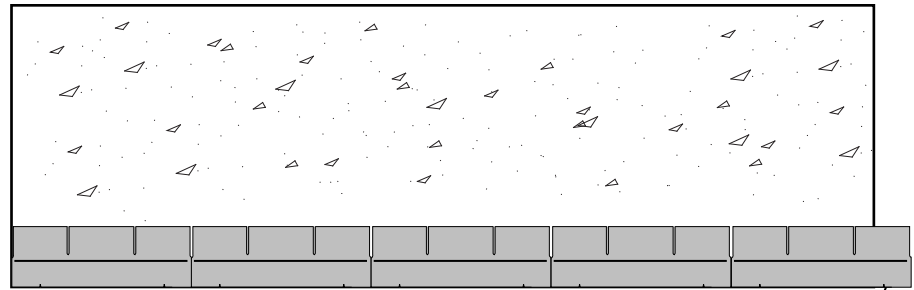

Flush to dripedge
Nivelado al gotero

Okay if Shingle Overlaps

Está bien si la teja sobresale

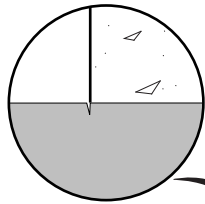

Line up notch on top of Shingle with edge of Roof to stagger the Shingles
Alinee el corte encima de la teja con el borde del techo para escalonar las tejas.

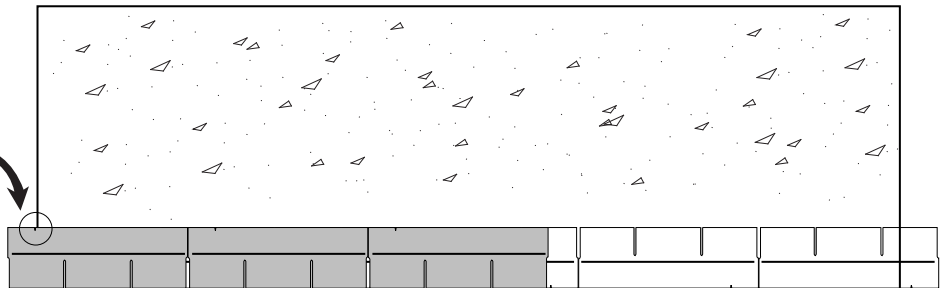

Maintain same dimension across
Mantenga la misma dimensión de un lado al otro

Flush to edge, stagger each row
Nivele al borde, escalone cada fila

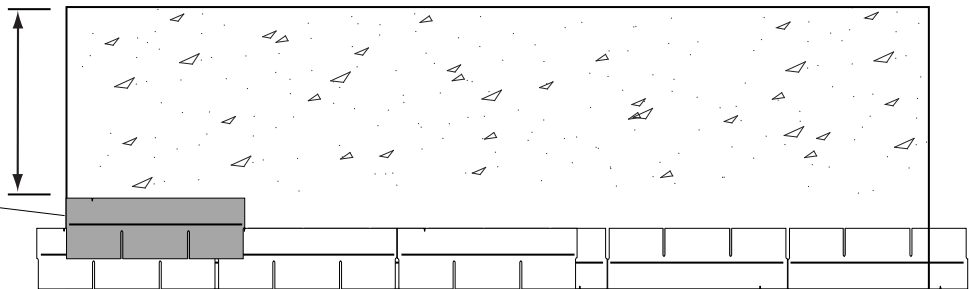

Remove overhanging shingles
Quite tejas sobresalientes

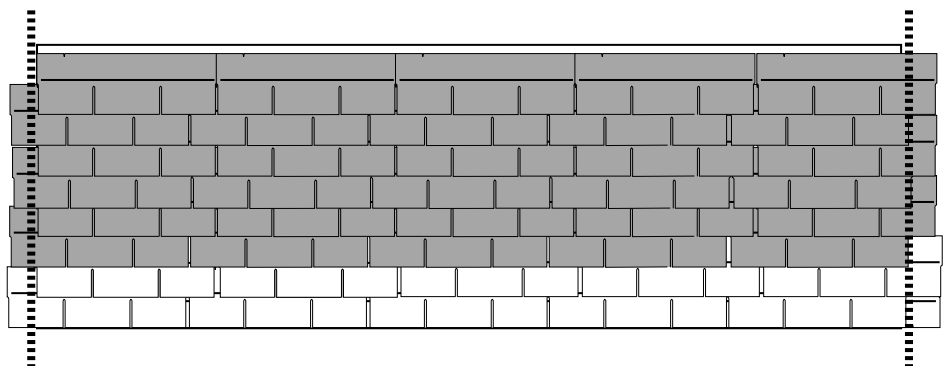

SHINGLES (Not Included)

Ridge Cap

Cut Shingles into 3 pieces
Corte las tejas en tres partes

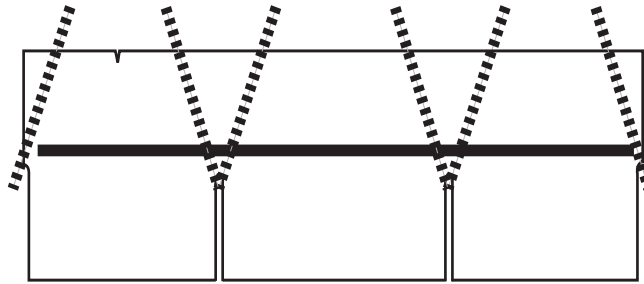

Apply pieces to ridge as shown
Fije las piezas a la cumbrera
como en el dibujo

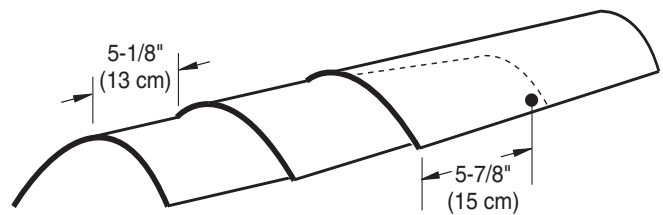

TEJAS (No Incluidas)

Tapa de cumbrera

NAIL INSPECTION INSPECCIÓN DE CLAVOS

Check for protruding nails, pound any protruding nails into the wood or cut them off flush.

Inspeccione para clavos sobresalientes; hínque clavos sobresalientes en la madera o córtelos nivelados con la madera.

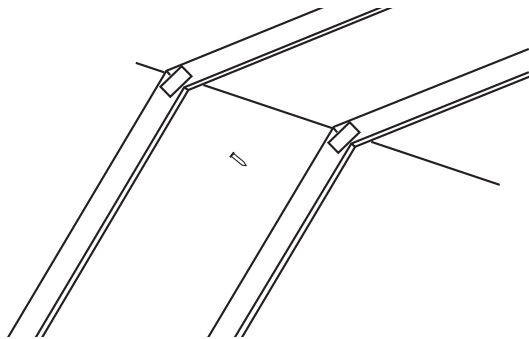

REQUIRED MAINTENANCE MANTENIMIENTO NECESARIO

Keep grass trimmed and away from building
Corte y quite la hierba cerca del edificio.

Keep Sprinklers away from building
No use rociadores cerca del edificio.

Repaint building as needed and in accordance with paint manufacturer requirements
Pinte el edificio de nuevo cada dos años.

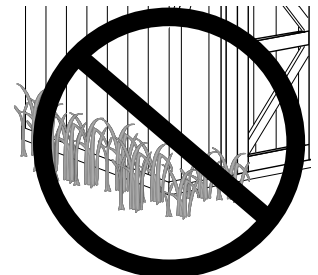

**Limited Conditional
Warranty ***

WARRANTY

Backyard Storage Solutions, LLC warrants the following:

1. Every product is warranted from defects in workmanship and manufacturing for one year.
2. All hardware and metal components are warranted for two years.
3. Trim is warranted for 10 years.
4. Waferboard siding and sheathing is warranted for two years.
5. SmartSide™ siding is warranted for 10 years on all Marco series buildings and 15 years on all Premier Series buildings.
6. Timber series buildings' siding and trim are warranted for 10 years.
7. Solar Shed windows are warranted for 1 year.
8. Cedar lumber is warranted for 15 years.
9. Cedar doors and Cedar Garden Center are warranted for 10 years.
10. Metal roof is warranted for 25 years.

Backyard Storage Solutions, LLC will repair, replace or pay for the affected part. In no event shall Backyard Storage Solutions, LLC pay the cost of labor or installation or any other costs related thereto. All warranties are from date of purchase. If a cash refund is paid on an affected part, it will be prorated from the date of purchase.

CONDITIONS

The warranty is effective only when:

1. The unit has been erected in accordance with the assembly instructions.
2. The unit has been properly shingled and painted or stained and reasonably and regularly maintained thereafter.
3. The failure occurs when the unit is owned by the original purchaser.
4. Backyard Storage Solutions, LLC has received the warranty registration card within thirty (30) days of purchase and notification of the failure in writing within the warranty period specified above.
5. Backyard Storage Solutions, LLC has had reasonable opportunity during the sixty (60) days following receipt of notification to inspect and verify the failure prior to commencement of any repair work.

REQUIREMENTS

Storage Buildings & Playhouses

To validate your warranty, it is necessary to properly maintain your Backyard Storage Solutions, LLC unit; shingle the roof and paint or solid-colored stain the siding using 100% acrylic latex exterior product with a minimum of two (2) coats within sixty (60) days of assembly; caulk above all doors and all horizontal and vertical trim boards; paint and seal all exposed edges, sides and faces of SmartSide™ and waferboard siding to include all exterior walls and all sides and all edges of doors.

Gazebos, Pergolas & Timber Buildings

To validate your warranty, it is necessary to properly maintain your Backyard Storage Solutions, LLC unit. This includes treating all of the exposed cedar and pine surfaces on your gazebo or timber building with an exterior grade wood preservative, an exterior oil-based semi-transparent stain, an acrylic latex exterior paint or an acrylic latex solid color exterior stain within 30 days of assembly and as needed thereafter to maintain your warranty.

Keep vegetation trimmed away from building and make sure siding panels and trim do not come in contact with masonry or cement. The minimum ground clearance for siding must be one half inch (½ inch) from concrete slab or two and one half inches (2 ½") from the ground when building is erected or constructed on a treated wood floor kit. Water from sprinklers must be kept off unit. In no event will Backyard Storage Solutions, LLC be responsible for any indirect, incidental, consequential or special damages nor for failure(s) that are caused by events, acts or omissions beyond our control including, but not limited to, misuse or improper assembly, improper maintenance (which eventually leads to rot or decay) and acts of God. Backyard Storage Solutions, LLC will not be held responsible for any labor costs incurred to construct your unit.

This warranty gives you certain specific rights that vary from state to state.

CLAIM PROCEDURE

To make a claim under this warranty, you can either call 1-888-827-9056 or prepare a letter. Please have ready the information below when you call or include the information when writing:

1. The model and size of the product.
2. A list of the part(s) for which the claim is made.
3. Proof of purchase of the Backyard Storage Solutions, LLC item, as shown on the original invoice.
4. Run code, as listed on the yellow warranty card enclosed in the product package.

Mail the above information to:

Backyard Storage Solutions, LLC
Attn: Customer Service
1000 Ternes
Monroe, MI 48162

***WARRANTY TERMS MAY VARY OUTSIDE THE U.S.A.**

IMPORTANT: This is your warranty certificate.

Please complete and mail your warranty card to properly validate your warranty.

Backyard Storage Solutions, LLC le garantiza a Ud. que:

1. Cada producto no tiene defecto de mano de obra ni de manufactura por un período de un año.
2. La ferretería y los componentes de metal están garantizados por dos años.
3. La moldura está garantizada por 10 años.
4. La cobertura y el entablado están garantizados por dos años.
5. La cobertura SmartSide™ está garantizada por 10 años para los edificios Marco Series, y por 15 años para los edificios Premier Series.
6. La cobertura y la moldura de los edificios Timber Series están garantizadas por 10 años.
7. Las ventanas del Solar Shed están garantizadas por un año.
8. La madera de cedro está garantizada por 15 años.
9. Las puertas del cedro y el Centro de jardín del Cedro son justificados durante 10 años.
10. El techo del metal es justificado durante 25 años.

Backyard Storage Solutions, LLC reparará, cambiará o pagará por la pieza afectada. En ningún caso pagará Backyard Storage Solutions, LLC los gastos de instalación o trabajo manual, o cualesquiera otros gastos relacionados a eso.

Condiciones

Esta garantía es válida solo cuando:

1. La unidad ha sido construida según las instrucciones.
2. La unidad ha sido cubierta de tejas y pintada de manera correcta y mantenida regularmente.
3. El defecto ocurre mientras la unidad está en la posesión del comprador original.
4. Backyard Storage Solutions, LLC ha recibido la tarjeta de garantía del producto en el plazo de 30 (treinta) días después de comprar la unidad y después de la notificación del defecto por escrito, durante el período de vigencia de la garantía especificada arriba.
5. Backyard Storage Solutions, LLC ha tenido una oportunidad razonable, durante los sesenta (60) días después de haber recibido la notificación, para inspeccionar y averiguar la falla o el defecto antes de comenzar cualquier reparación.

Requisitos

Cobertizos de almacenamiento y Casitas de niños

Para dar validez a la garantía, es necesario mantener bien su unidad de Backyard Storage Solutions, LLC: cubrir con tejas el techo, pintar la cobertura con un producto 100% de acrílico y de látex para exteriores, usando dos manos de pintura o tinte, como mínimo, en el plazo de sesenta (60) días después de la construcción; masillar arriba de todas las puertas y todos los paneles de moldura horizontales y verticales; pintar y sellar todos los bordes dispuestos al exterior, los lados y las fachadas de la cobertura SmartSide™ y plano, incluyendo todos los muros exteriores y los lados y bordes de las puertas.

Belvederes, Pergolas y Edificios de Madera

Para dar validez a la garantía, es necesario mantener bien su unidad. Eso incluye tratar con un preservativo todos los superficies de cedro y de pino dispuestos al exterior, usando un preservativo para madera, un tinte de aceite semitransparente para exteriores, pintura acrílica de látex para exteriores, o un tinte acrílico de látex de un solo color, en el plazo de treinta (30) días después de construir el edificio, y luego como sea necesario.

Mantenga corta toda clase de vegetación cerca del edificio y asegúrese que la cobertura y la moldura no toquen ninguna obra de albañería o el cemento. El margen mínimo entre el suelo y la cobertura debe de ser media pulgada (1/2"), con un base de concreto; dos pulgadas y media (2 1/2") cuando se construye el edificio sobre un base de madera (usando un equipo de madera tratada). No se deben usar rociadores cerca de la unidad. En ningún caso será responsable Backyard Storage Solutions, LLC de daños especiales, incidentales, consiguientes o indirectos, ni de fallas causadas por sucesos, hechos u omisiones fuera de nuestro control; eso incluye, pero no está limitado a: el misuso; la construcción incorrecta; cuidado incorrecto (el cual causa, eventualmente, la putrefacción o la descomposición) y acciones de la naturaleza. Backyard Storage Solutions, LLC no será responsable de ningún gasto de instalación incurrido durante la construcción de la unidad. Esta garantía le da a Ud. ciertos derechos específicos que varían de estado a estado.

Para hacer una reclamación:

Para hacer una reclamación bajo esta garantía, llame al 1-888- 827-9056 o escriba una carta. Favor de tener la siguiente información al llamarnos, o incluirla al escribirnos:

1. El modelo y el tamaño del producto.
2. Una lista de las piezas por las cuales hace Ud. la reclamación.
3. Prueba de compra del producto, como se muestra en la factura original.
4. (Run code) escrita en la tarjeta amarilla de garantía incluida con el producto.

Envíe la información a:

Backyard Storage Solutions, LLC
Attn: Customer Service
1000 Ternes
Monroe, MI 48162
USA

***LAS CONDICIONES DE LA GARANTIA PUEDEN VARIAR FUERA DE ESTADOS UNIDOS**

IMPORTANTE: Esta página es su certificado de garantía.

Favor de llenar completamente y enviar la tarjeta de garantía para dar validez a la garantía.

ldr: 01/06/09