

# Installation Instructions / Warranty

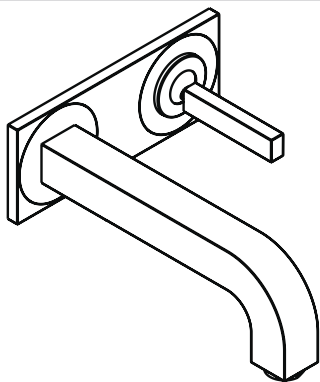

**Citterio**  
39115XX1

# AXOR<sup>®</sup>

hansgrohe

# Citterio Wall-Mount Lavatory Trim 39115XX1

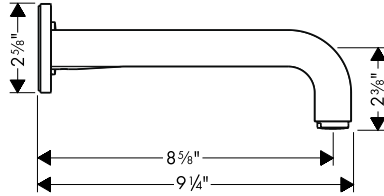
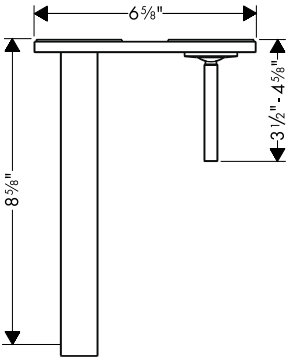

## Technical Data

Maximum incoming water pressure	145 psi
Recommended incoming pressure	14.5 - 72 psi
Recommended hot water temperature	120°F - 140°F*
Flow rate	2.2 gpm

The hot and cold supplies must be of equal pressure for proper operation of the faucet.

\*Know and follow all applicable local codes when setting the temperature of the water heater.

## Installation Considerations

- Rough-in 38111181 (purchased separately) must be installed and the finished wall complete before installation of this trim kit.
- For best results, Hansgrohe recommends installation by a licensed, professional plumber.
- No drain is included with this faucet. Contact the manufacturer of the sink for recommendations regarding suitable drains.
- Turn the water off at the main before beginning installation.

### Recommended tools (not included)

27 mm & 17 mm deep sockets

12 mm allen wrench

Teflon™ thread tape

cutting tools

waterproof bathroom sealant, compatible with the wall surface

# Installation Instructions

TURN OFF THE WATER AT THE SUPPLY BEFORE BEGINNING THE INSTALLATION.

- Remove the caps from the plaster shields. Cut the plaster shields 1 mm (1/16") from the surface of the finished wall. Seal around the plaster shields with a suitable, non-staining, waterproof bathroom sealant.

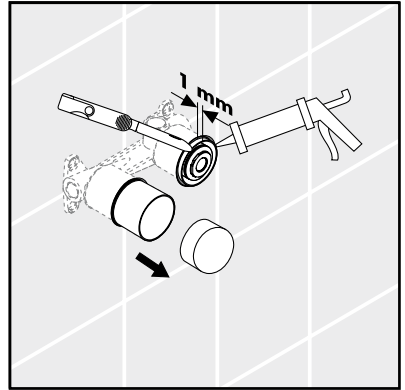

- Use a 27 mm deep socket wrench to remove the flush insert.
- Use a 17 mm deep socket wrench to remove the plug from the spout port.

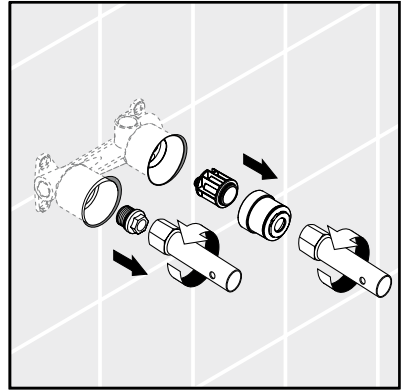

- Install the cartridge and anti twist device to the cartridge housing. Make sure that the cartridge is oriented as shown in the diagram.

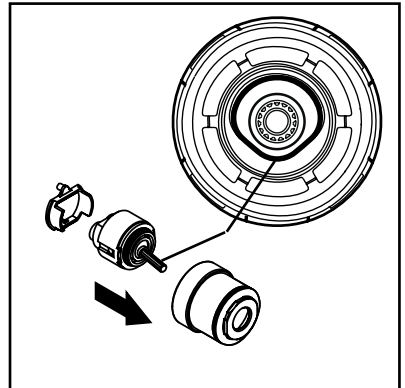

- Install the springs and cup washers in the valve body. Install the cartridge assembly.

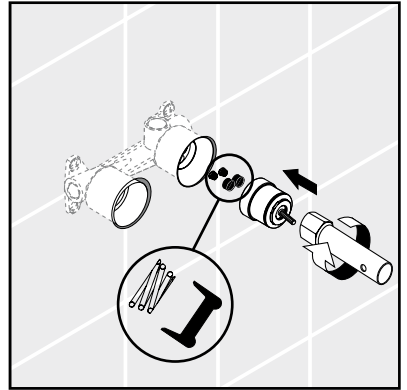

- Install the handle. Tighten the set screw using the enclosed 2 mm allen wrench.

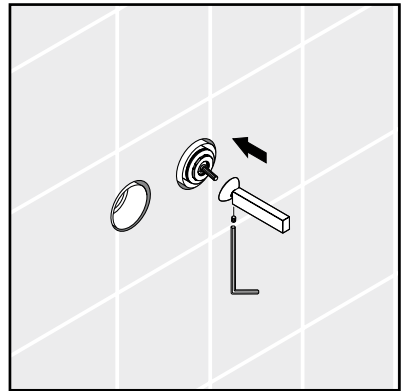

- Measure the distance from the surface of the finished wall to the end of the handle.

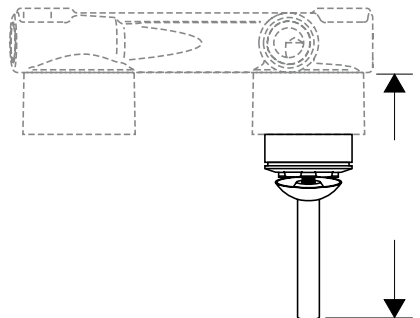

If the distance is  $3 \frac{1}{4}'' - 3 \frac{7}{8}''$ , select the two "A" sleeves ( $1\text{-}1\frac{1}{4}''$  long).



If the distance is  $3 \frac{7}{8}'' - 4 \frac{3}{8}''$ , select the two "B" sleeves ( $\frac{7}{8}''$  long)

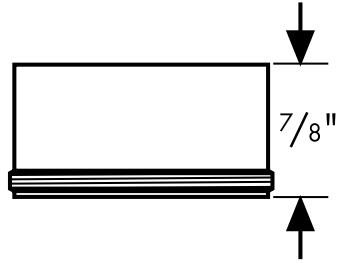

If the distance is  $4 \frac{3}{8}''$ , select the two "C" sleeves ( $\frac{1}{2}''$  long)

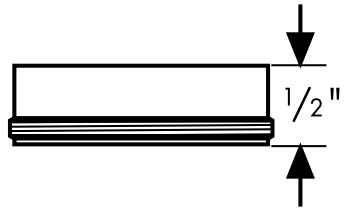

Screw the escutcheon retainers to the ends of the two sleeves.

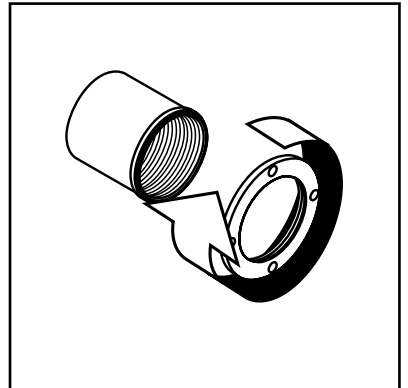

- Measure the distance from the outside surface of the finished wall to the spout port ("X"). Add 2" to X

- Measure the threaded end of the spout. Using proper tools and safety practices, cut the spout so that the threaded portion is  $X + 2''$  long.

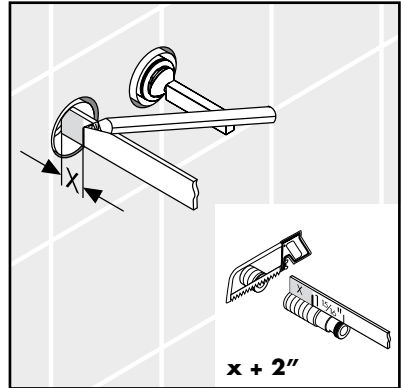

- Wrap the threads on the spout connector with several layers of a good quality Teflon™ tape. Screw the spout connector into the rough.

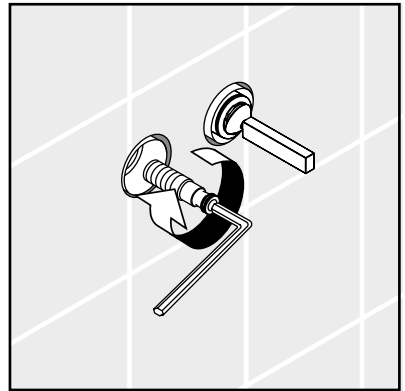

- Place the face plate against the wall. Screw the sleeve/escutcheon retainer assemblies through the plate and into the rough.

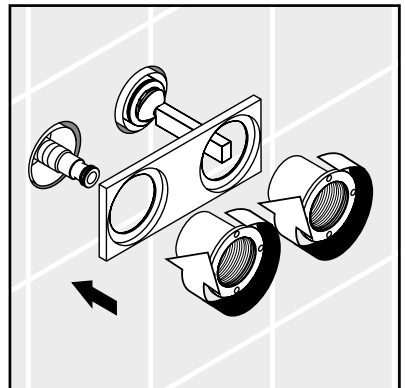

- Use the service key to tighten the escutcheon retainers against the plate.

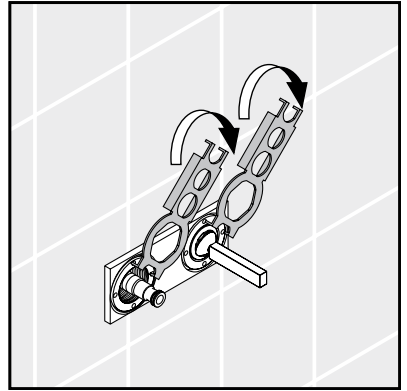

- Lightly coat the threads on the flanges with the included lubricant. Screw the flanges onto the retainers.

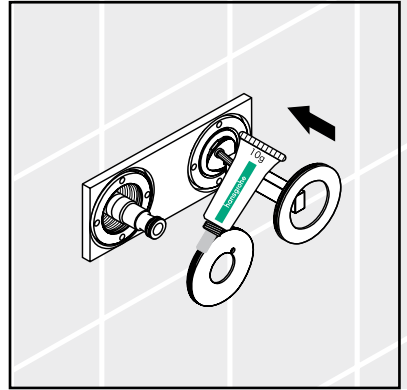

- Push the cap over the handle assembly. Push the spout over the connector and tighten the set screw.

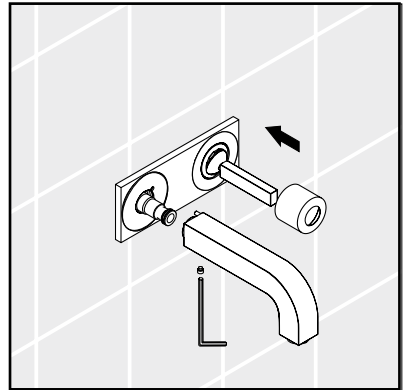

# User Instructions

Lift the handle to turn the faucet on. Pivot the handle to the left for warmer water, to the right for cooler water. Push the handle down to turn the water off.

## Replacement Parts

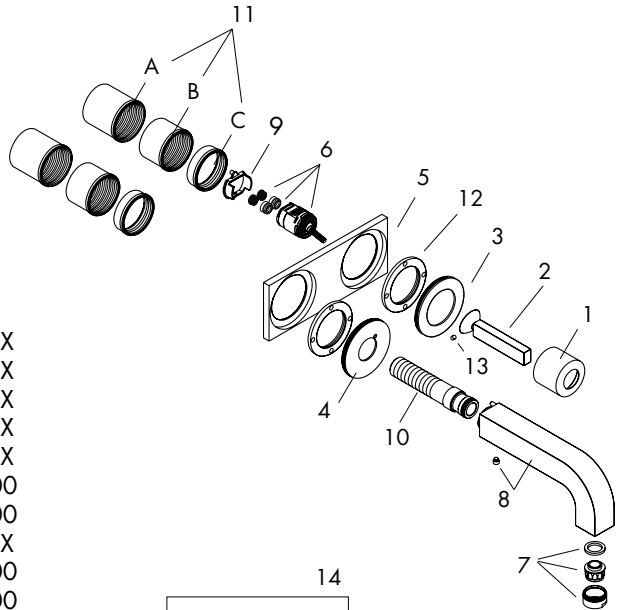

1	flange	96908XXX
2	handle	39092XXX
3	flange for handle	96912XXX
4	flange for spout	97695XXX
5	face plate	96914XXX
6	cartridge	96339000
7	aerator	13085000
8	spout	97239XXX
9	anti-twist device	97280000
10	spout connector	97228000
11	fixing set	97971000
12	nut	97601000
13	hollow set screw M4x6	97767000
14	extension kit	38982000 (optional)

XXX = color  
 000 = chrome  
 820 = brushed nickel



# Cleaning Recommendation for Hansgrohe Products

Modern faucetry and shower products utilize a combination of materials to comply with the needs of the market with regard to design and functionality.

To avoid damage, it is necessary to use some caution when cleaning. Damage caused by improper treatment is not covered under the Hansgrohe warranty.

## Cleaning Materials for Faucets and Showers

- To remove lime scale, use only products made specifically for that purpose. Always follow the manufacturer's instructions when using.
- Do not use cleaners that contain hydrochloric, formic, acetic, or phosphoric acids, as these will cause considerable damage to finishes and to plastic components.
- Never mix cleaning materials.
- Never use cleaners containing abrasives. Do not use abrasive cleaning cloths, pads, or sponges.

## Cleaning Procedures

- Clean your faucets and shower products as and when required. Regular cleaning will prevent scale buildup and water spotting.
- Follow the label instructions. Do not allow any cleaner to remain on the product for longer than necessary.
- When using spray cleaners, spray first onto a sponge or cloth – do not spray directly onto the product.
- After cleaning, rinse thoroughly with clear water to remove any cleaner residue.

## Important

- Soap and shampoo residue can also cause damage to the product. Rinse well with clean water after use.
- If the surface is already damaged, harsh cleaning materials will cause further damage.

## Limited Lifetime Consumer Warranty

This product has been manufactured and tested to the highest quality standards by Hansgrohe, Inc. ("Hansgrohe"). This warranty is limited to Hansgrohe products which are purchased by a consumer in the United States after March 1, 1996, and installed in either the United States or Canada.

### WHO IS COVERED BY THE WARRANTY

This warranty extends to the original consumer purchaser only. This warranty is non-transferable.

### WHAT IS COVERED BY THE WARRANTY

This warranty covers only your Hansgrohe manufactured product. Hansgrohe warrants this product against defects in material or workmanship as follows: Hansgrohe will repair at no charge for parts only or, at its option, replace any product or part of the product that proves defective because of improper workmanship and/or material, under normal installation, use, service and maintenance. If Hansgrohe is unable to provide a replacement and repair is not practical or cannot be timely made, Hansgrohe may elect to refund the purchase price in exchange for the return of the product.

### LENGTH OF WARRANTY

Replacement or repaired parts of products will be covered for the term of this warranty as stated in the following two sentences. If you are a consumer who purchased the product for use primarily for personal, family, or household purposes, this warranty extends for as long as you own the product and the home in which the product is originally installed. If you purchased the product for use primarily for any other purpose, including, without limitation, a commercial purpose, this warranty extends only (i) for 1 year, with respect to Hansgrohe and Commercial products, and (ii) for 5 years, with respect to AXOR products.

### THIS WARRANTY DOES NOT COVER, AND HANSGROHE WILL NOT PAY FOR:

- A. Conditions, malfunctions or damage not resulting from defects in material or workmanship.
- B. Conditions, malfunctions or damage resulting from (1) normal wear and tear, improper installation, improper maintenance, misuse, abuse, negligence, accident or alteration, or (2) the use of abrasive or caustic cleaning agents or "no-rinse" cleaning products, or the use of the product in any manner contrary to the product instructions. (3) Conditions in the home such as excessive water pressure or corrosion.
- C. Labor or other expenses for the disconnection, deinstallation, or return of the product for warranty service, or for installation or reinstallation of the product (including but not limited to proper packaging and shipping costs), or for installation or reinstallation of the product.
- D. Accessories, connected materials and products, or related products not manufactured by Hansgrohe.

## **TO OBTAIN WARRANTY PARTS OR INFORMATION**

Contact your Hansgrohe retailer, or contact Technical Service at:

Hansgrohe Inc.  
1492 Bluegrass Lakes Parkway  
Alpharetta GA 30004  
Toll-free (800) 334-0455.

In requesting warranty service, you will need to provide

1. The sales receipt or other evidence of the date and place of purchase.
2. A description of the problem.
3. Delivery of the product or the defective part, postage prepaid and carefully packed and insured, to Hansgrohe Inc. 1492 Bluegrass Lakes Parkway, Alpharetta, Georgia 30004, Attention: Technical Service, if required by Hansgrohe.

When warranty service is completed, any repaired or replacement product or part will be returned to you postage prepaid.

## **EXCLUSIONS AND LIMITATIONS**

**REPAIR OR REPLACEMENT (OR, IN LIMITED CIRCUMSTANCES, REFUND OF THE PURCHASE PRICE) AS PROVIDED UNDER THIS WARRANTY IS THE EXCLUSIVE REMEDY OF THE PURCHASER. HANSGROHE NEITHER ASSUMES NOR AUTHORIZES ANY PERSON TO CREATE FOR IT ANY OBLIGATION OR LIABILITY IN CONNECTION WITH THIS PRODUCT.**

**HANSGROHE SHALL NOT BE LIABLE TO PURCHASER OR ANY PERSON FOR ANY INCIDENTAL, SPECIAL, OR CONSEQUENTIAL DAMAGES, ARISING OUT OF BREACH OF THIS WARRANTY OR ANY IMPLIED WARRANTY (INCLUDING MERCHANTABILITY).**

Some States do not allow the exclusion or limitation of incidental or consequential damages, so the above limitation or exclusion may not apply to you. This warranty gives you specific legal rights, and you may have other rights which vary from State to State. You may be required by law to give us a reasonable opportunity to correct or cure any failure to comply before you can bring any action in court against us under the Magnuson-Moss Warranty Act.

## **PRODUCT INSTRUCTIONS AND QUESTIONS**

Upon purchase or prior to installation, please carefully inspect your Hansgrohe product for any damage or visible defect. Prior to installing, always carefully study the enclosed instructions on the proper installation and the care and maintenance of the product. If you have questions at any time about the use, installation, or performance of your Hansgrohe product, or this warranty, please call or write to us or call us toll-free at 800 334 0455.

**hansgrohe**

Hansgrohe, Inc. • 1490 Bluegrass Lakes Parkway • Alpharetta, GA 30004  
Tel. 770 360-9880 • Fax 770 360 9887

**[www.hansgrohe-USA.com](http://www.hansgrohe-USA.com)**