

**Showerheaven**  
10625XX1

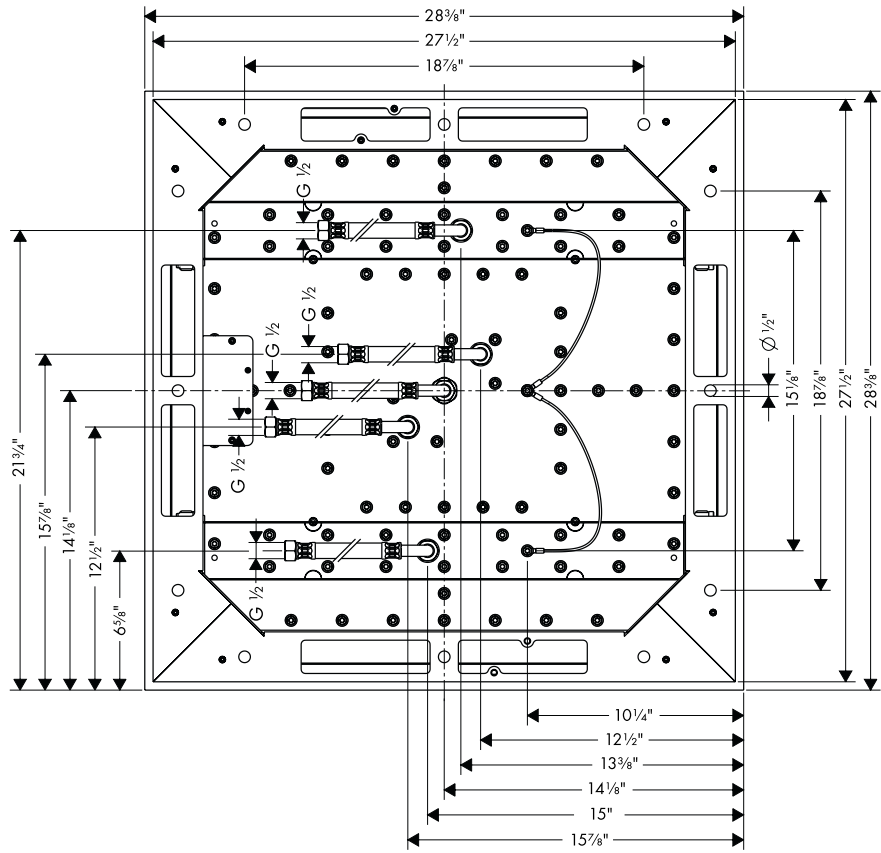

# Spray Functions / Fonctions de jet / Funciones de rociado

**Rain**

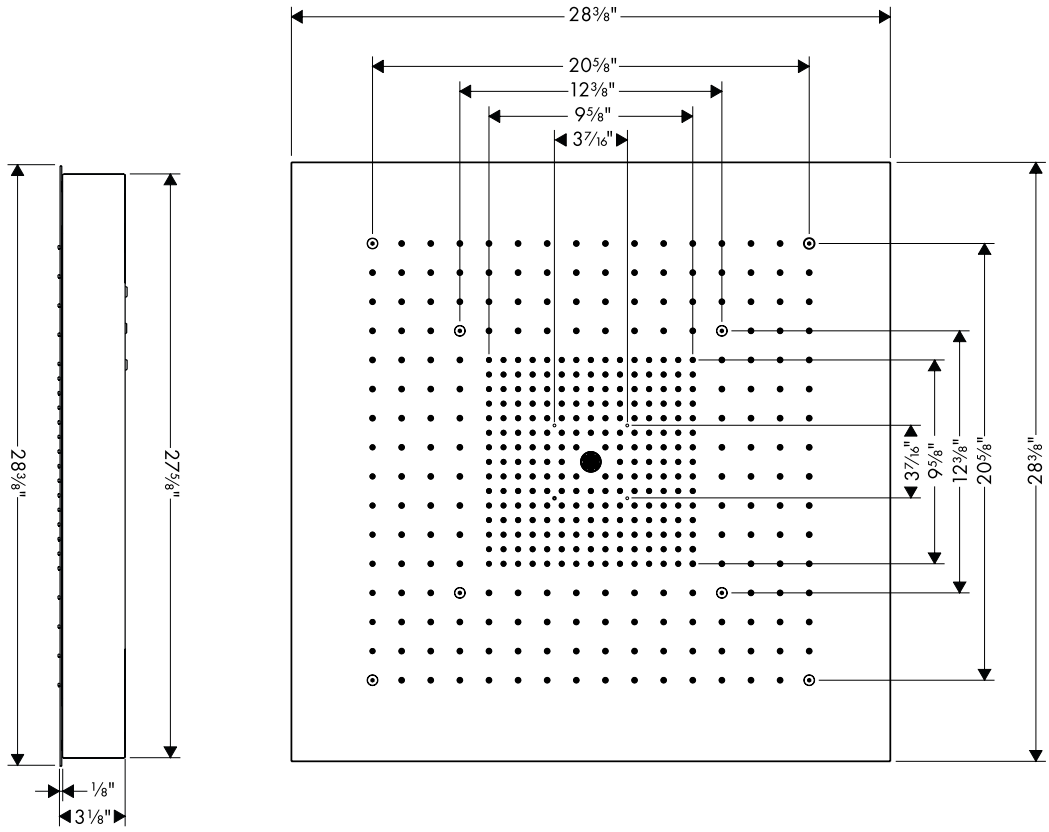
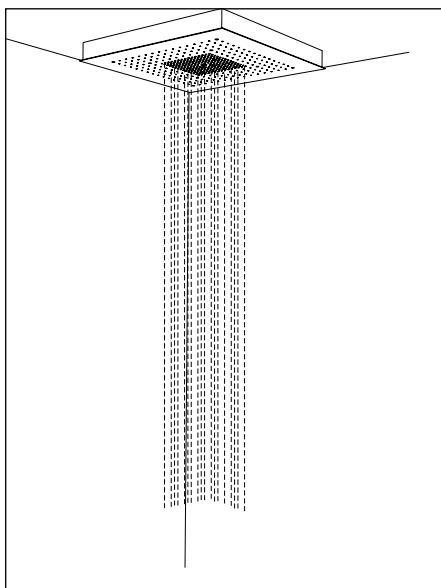

**Laminar**

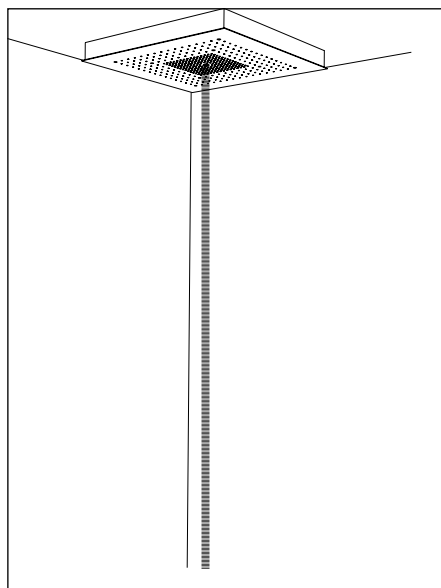

**Body**

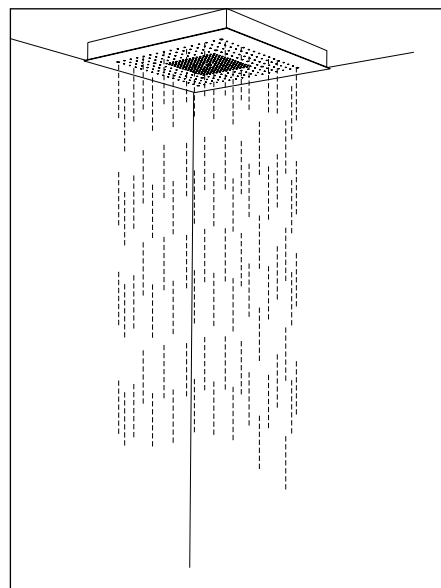

## Flow rate / Capacité nominale / Caudal máximo

2.5 gpm per spray mode

## Package Contents / Contenu de l'emballage / Contenido del paquete

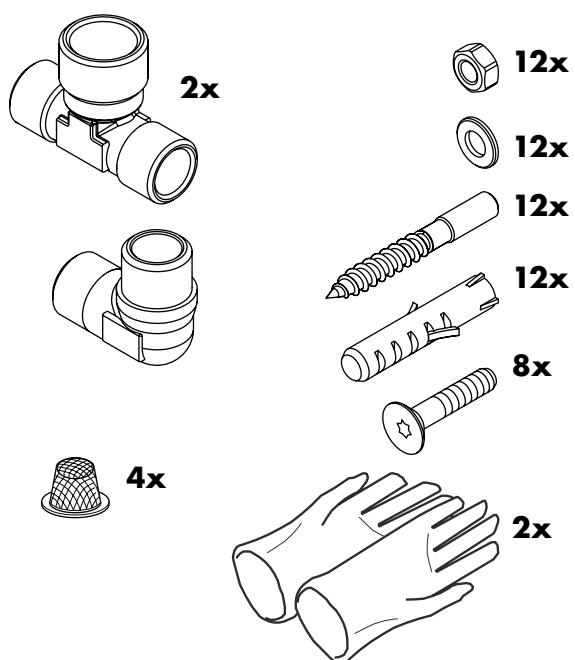

## Required Tools (not included) / Outils requis (pas inclus) / Herramientas necesarias (no incluidos)

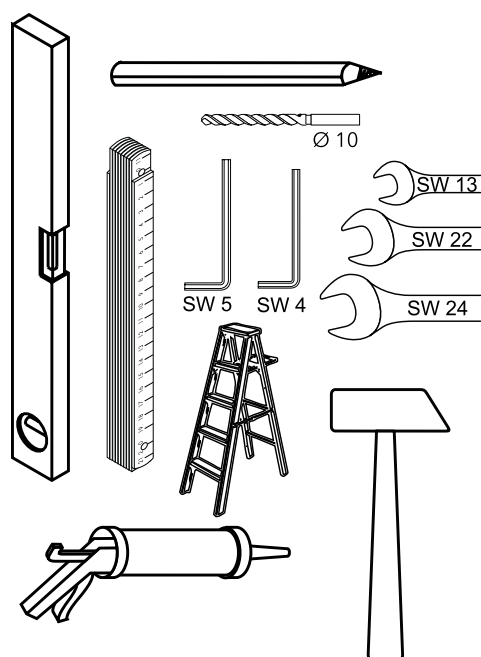

Installation Suggestions / Suggestions d'installation / Sugerencias para la instalación

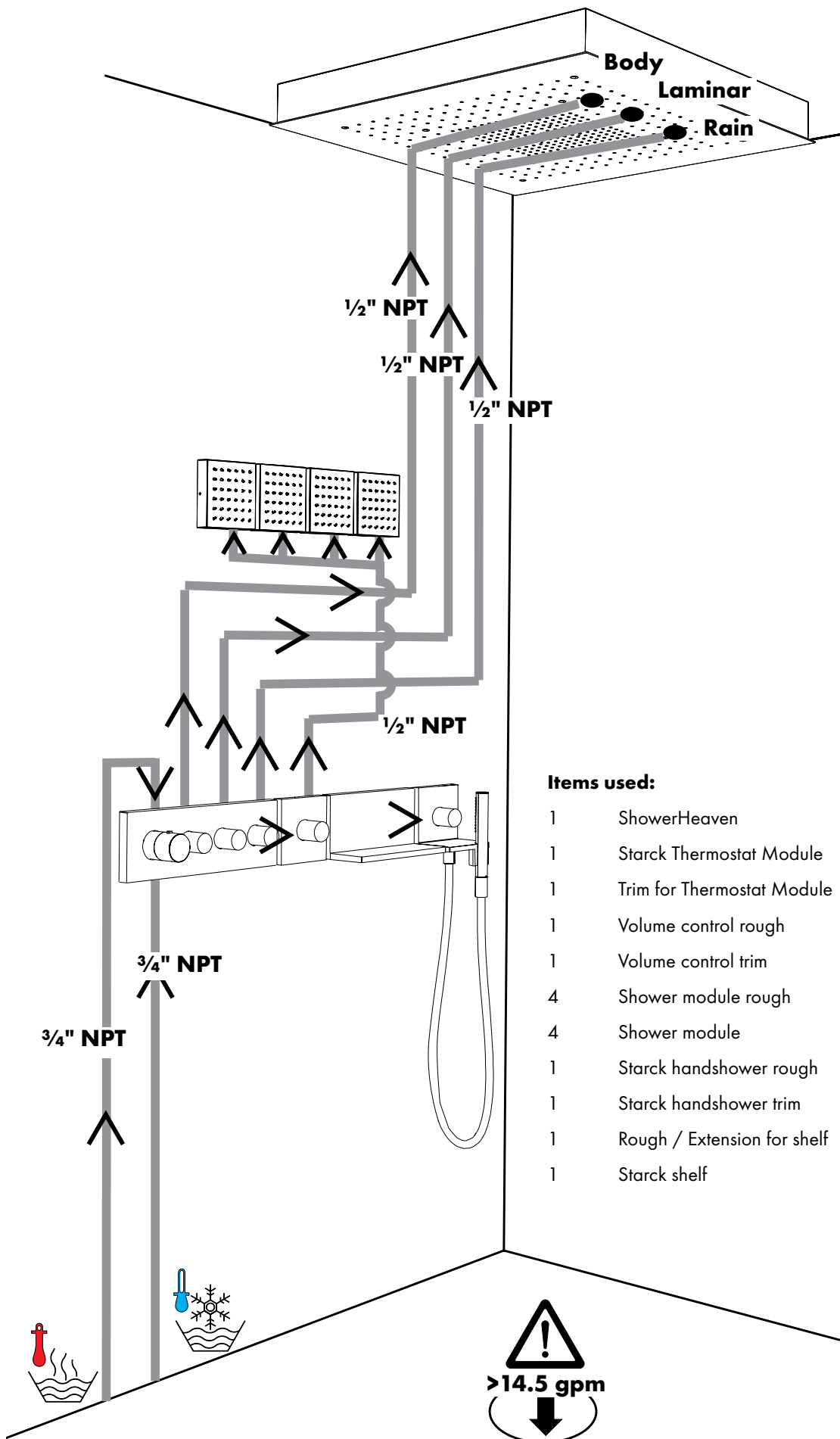

Items used:

- |   |                             |          |
|---|-----------------------------|----------|
| 1 | ShowerHeaven                | 10625XX1 |
| 1 | Starck Thermostat Module    | 10750181 |
| 1 | Trim for Thermostat Module  | 10751XX1 |
| 1 | Volume control rough        | 10971181 |
| 1 | Volume control trim         | 10972XX1 |
| 4 | Shower module rough         | 28486181 |
| 4 | Shower module               | 28491XX1 |
| 1 | Starck handshower rough     | 10650181 |
| 1 | Starck handshower trim      | 10651XX1 |
| 1 | Rough / Extension for shelf | 40878180 |
| 1 | Starck shelf                | 40873XX0 |



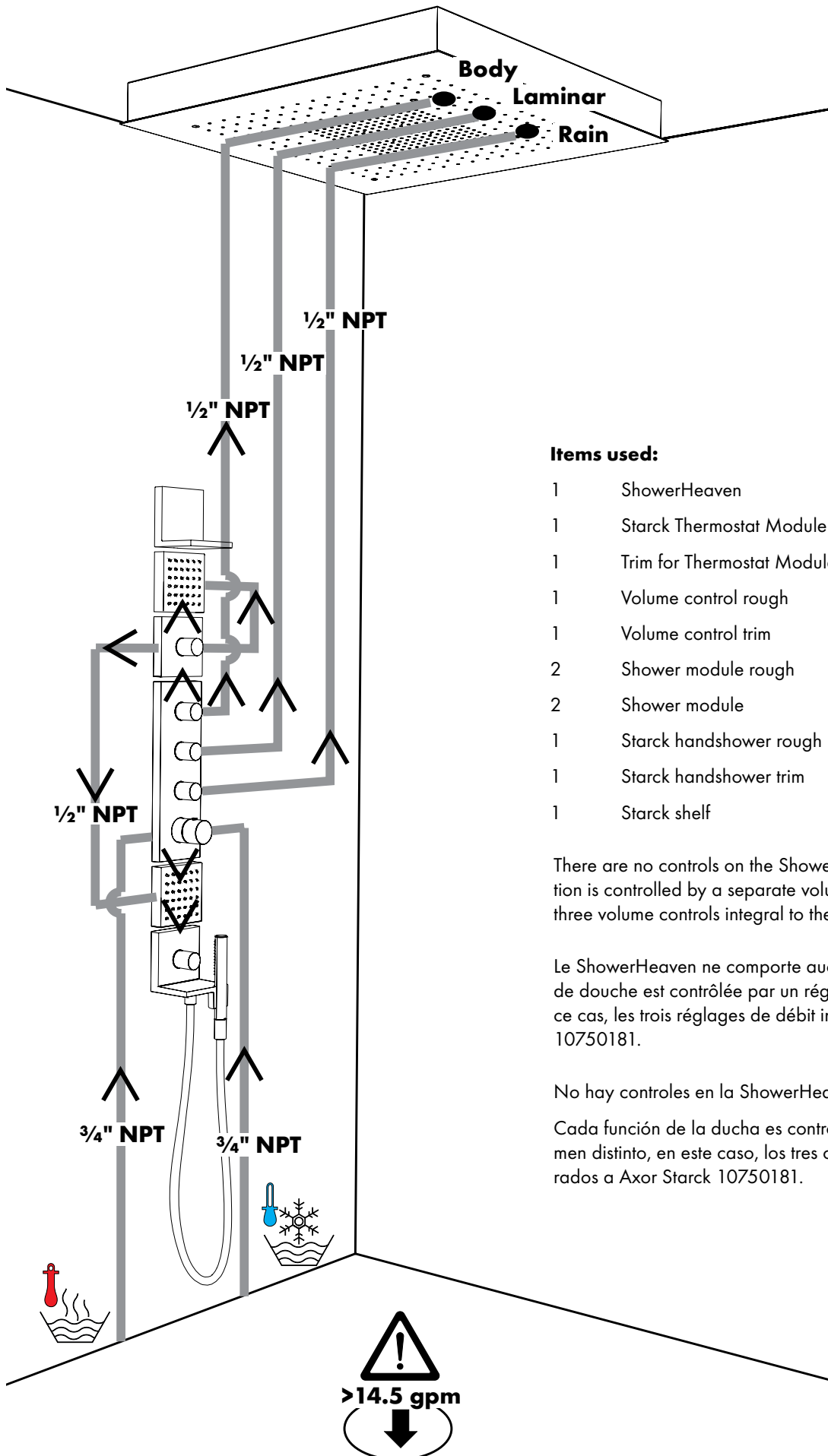

**Items used:**

1	ShowerHeaven	10625XX1
1	Starck Thermostat Module	10750181
1	Trim for Thermostat Module	10751XX1
1	Volume control rough	10971181
1	Volume control trim	10972XX1
2	Shower module rough	28486181
2	Shower module	28491XX1
1	Starck handshower rough	10650181
1	Starck handshower trim	10651XX1
1	Starck shelf	40872XX0

There are no controls on the ShowerHeaven. Each shower function is controlled by a separate volume control – in this case, the three volume controls integral to the Axor Starck 10750181.

Le ShowerHeaven ne comporte aucun réglage. Chaque fonction de douche est contrôlée par un réglage de débit séparé – dans ce cas, les trois réglages de débit intégrés du Axor Starck 10750181.

No hay controles en la ShowerHeaven.

Cada función de la ducha es controlada por un control de volumen distinto, en este caso, los tres controles de volumen incorporados a Axor Starck 10750181.

Decide where the hinges are to be positioned.

Décidez de l'endroit où vous souhaitez positionner les charnières.

Decida dónde se ubicarán las bisagras.

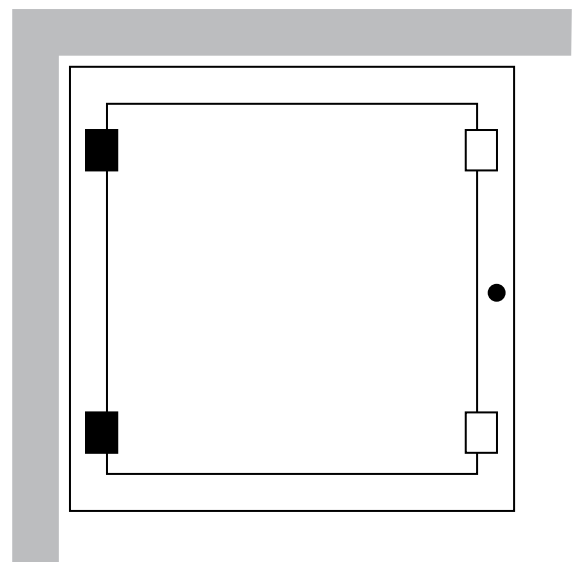
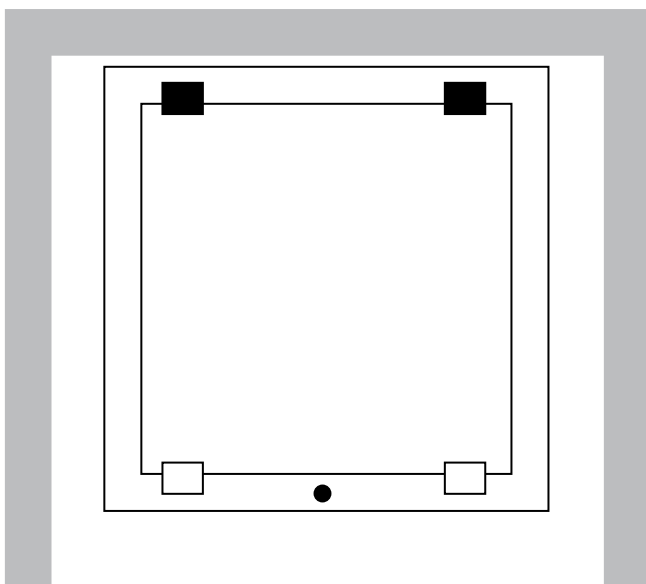
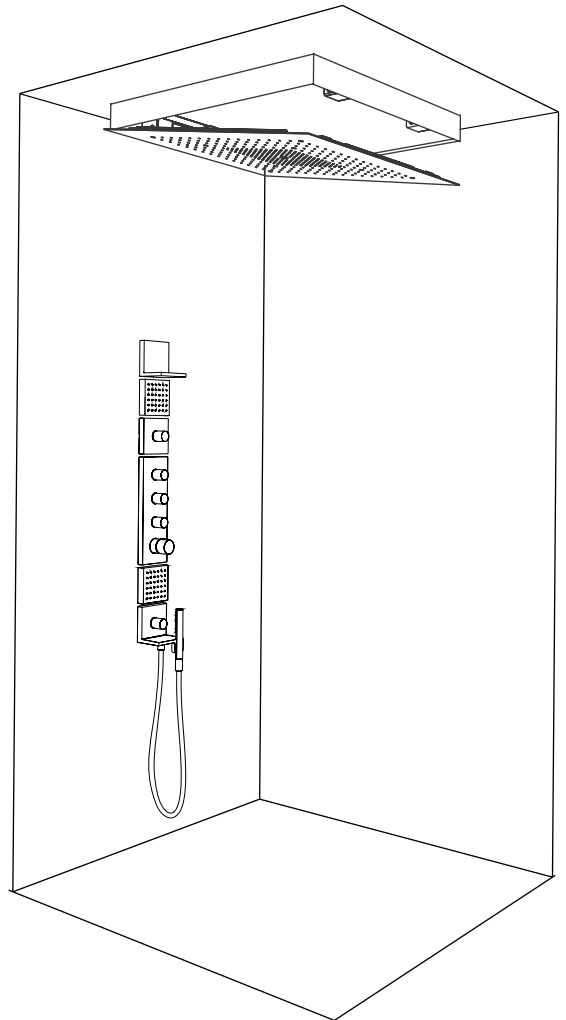
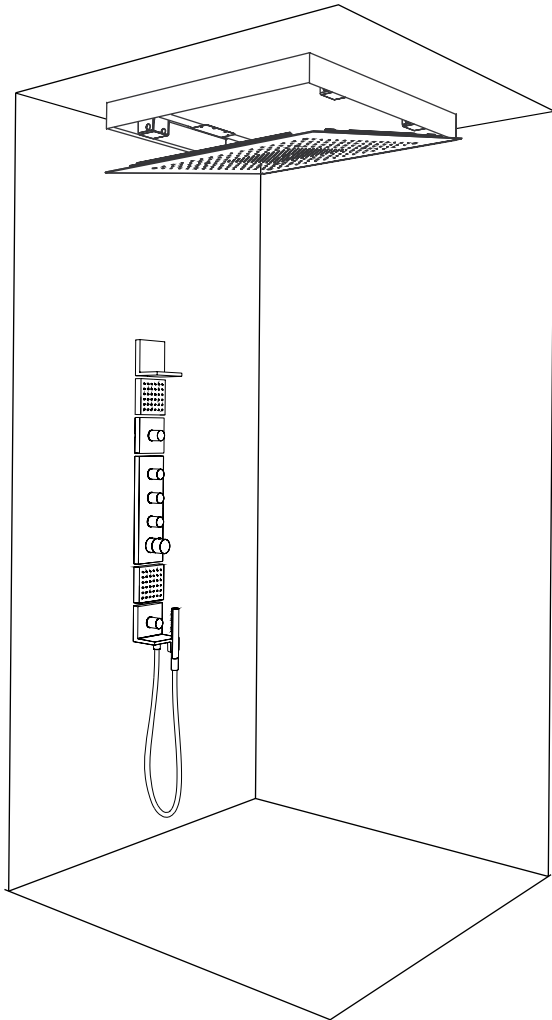

## Installation Considerations

- For best results, Hansgrohe recommends that this unit be installed by a licensed, professional plumber.
- Please read over these instructions thoroughly before beginning installation. Make sure that you have all tools and supplies needed to complete the installation.
- To prevent scald injury, the maximum output temperature of the shower valve should be no higher than 120°F. In Massachusetts, the maximum output temperature of the shower valve can be no higher than 112°F.
- Keep this booklet and the receipt (or other proof of date and place of purchase) for this product in a safe place. The receipt is required should it be necessary to request warranty parts.

## À prendre en considération pour l'installation

- Pour de meilleurs résultats, Hansgrohe recommande que ce produit soit installé par un plombier professionnel licencié.
- Veuillez lire attentivement ces instructions avant de procéder à l'installation. Assurez-vous de disposer de tous les outils et du matériel nécessaires pour l'installation.
- Pour empêcher des blessures par ébullition, la température de sortie maximale du robinet de douche ne doit pas excéder 120°F. Au Massachusetts, la température de sortie maximale du robinet de douche ne doit pas excéder 112°F.
- Conservez ce livret et le reçu (ou une autre preuve sur laquelle figurent la date et l'endroit de l'achat) pour ce produit dans un endroit sûr. Le reçu est requis si vous commandez des pièces sous garantie.

## Consideraciones para la instalación

- Para obtener mejores resultados, la instalación debe estar a cargo de un plomero profesional matriculado.
- Antes de comenzar la instalación, lea estas instrucciones detenidamente. Asegúrese de tener las herramientas y los insumos necesarios para completar la instalación.
- Para evitar escaldaduras, la máxima temperatura de salida de la válvula de la ducha no debe exceder los 120°F. En Massachusetts, la máxima temperatura de salida de la válvula de la ducha no debe exceder los 112°F.
- Mantenga este folleto y el recibo (u otro comprobante del lugar y fecha de compra) de este producto en lugar seguro. El recibo se requiere en caso de ser necesario solicitar piezas bajo garantía.

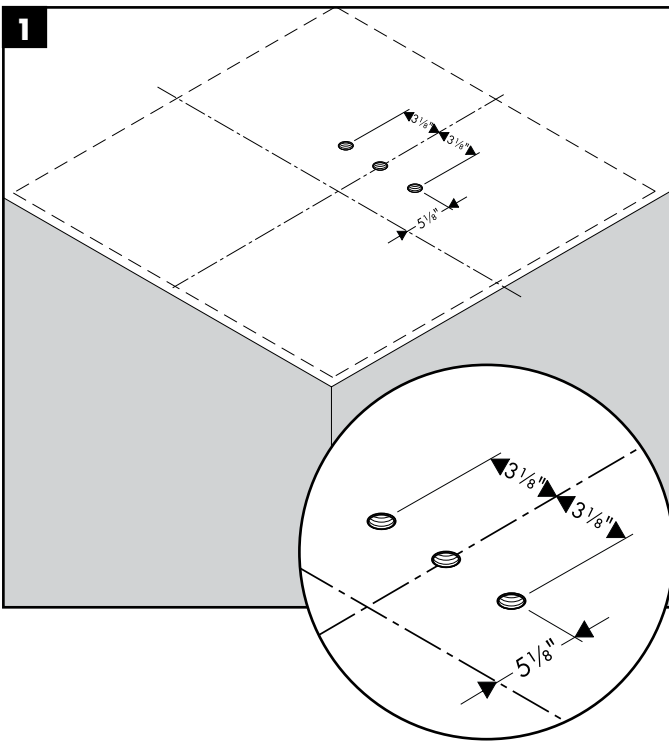

### Roughing-In

The ShowerHeaven requires three 1/2" NPT female fittings, positioned as shown in the diagram, flush with the surface of the ceiling.

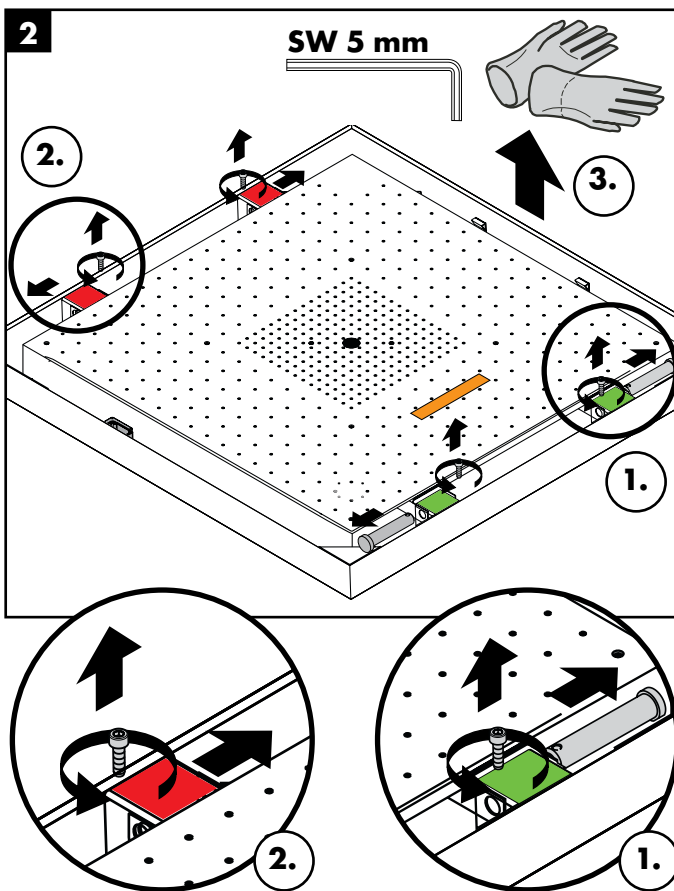

### Installation

Wear gloves while installing the ShowerHeaven.

Remove the screws using a 5 mm Allen wrench. Remove the hinge pins. (1), (2).

Remove the spray body from the frame (3).



**Pièce intérieure**

Le ShowerHeaven nécessite l'utilisation de trois raccords femelles filetés NPT de ½ po, positionnés de la façon indiquée sur le schéma.

**Piezas interiores**

La ShowerHeaven requiere conexiones hembra NPT de ½", ubicadas como se muestra en el dibujo.

**Installation**

Retirez les vis à l'aide d'une clé hexagonale de 4 mm. Retirez les broches de charnière. (1), (2).

Retirez la plaque de jet du cadre (3).

**Instalación**

Retire los tornillos con una llave Allen de 4 mm. Retire los pasadores de bisagra. (1), (2).

Retire el cuerpo de rociado del marco (3).

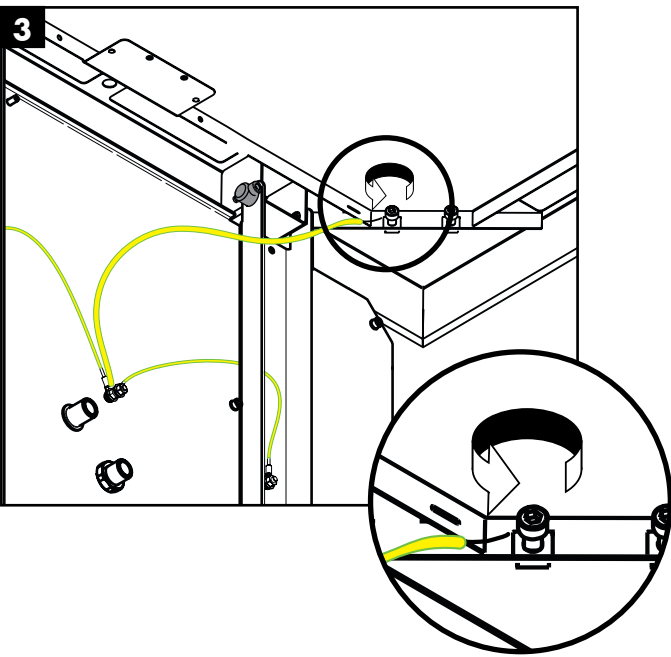

Disconnect the grounding wire from the frame.

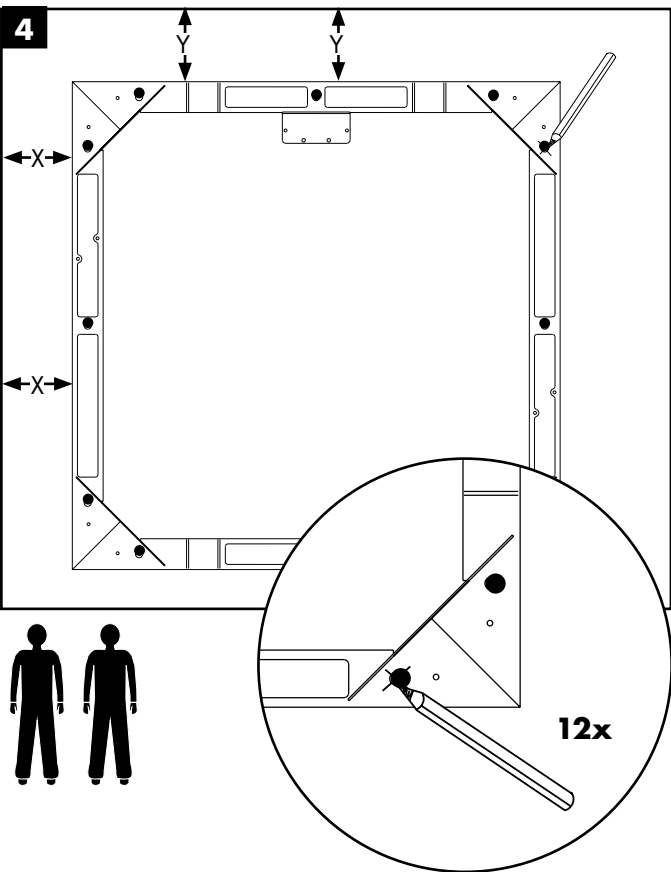

Have a helper hold the frame against the ceiling.

Mark the positions of the 12 screw holes.

Débranchez le PE fil du cadre.

Desconecte el alambre PE del marco.

Demandez à quelqu'un de maintenir le cadre contre le plafond.  
Marquez les positions des 12 trous de vissage.

Haga que un ayudante sostenga el marco contra el cielo raso.  
Marque las posiciones de los 12 orificios para tornillos.

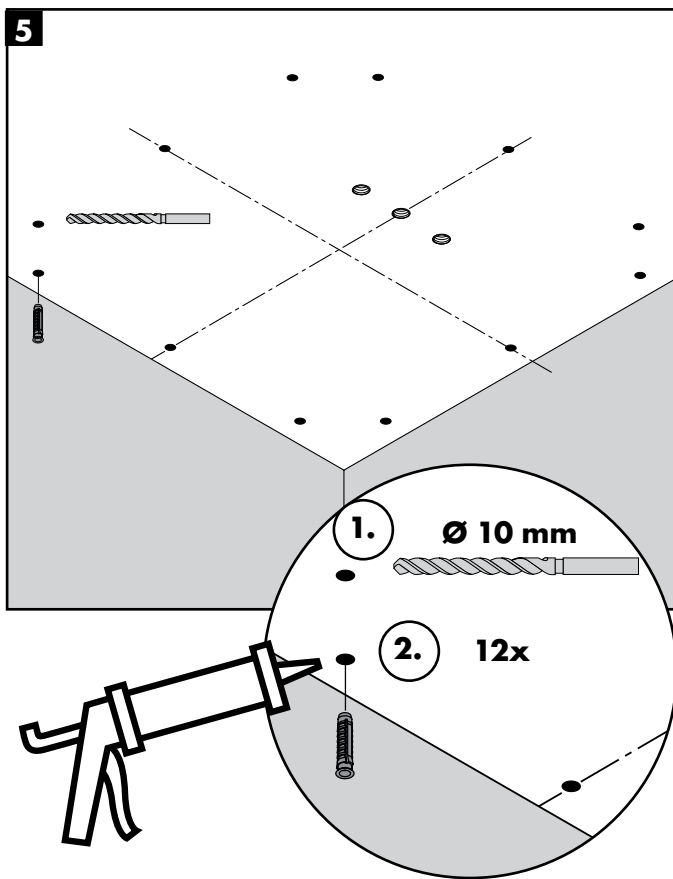

Drill the screw holes using a 10mm bit (1).

Install the anchors (2). Seal the ceiling around the anchors using waterproof sealant.

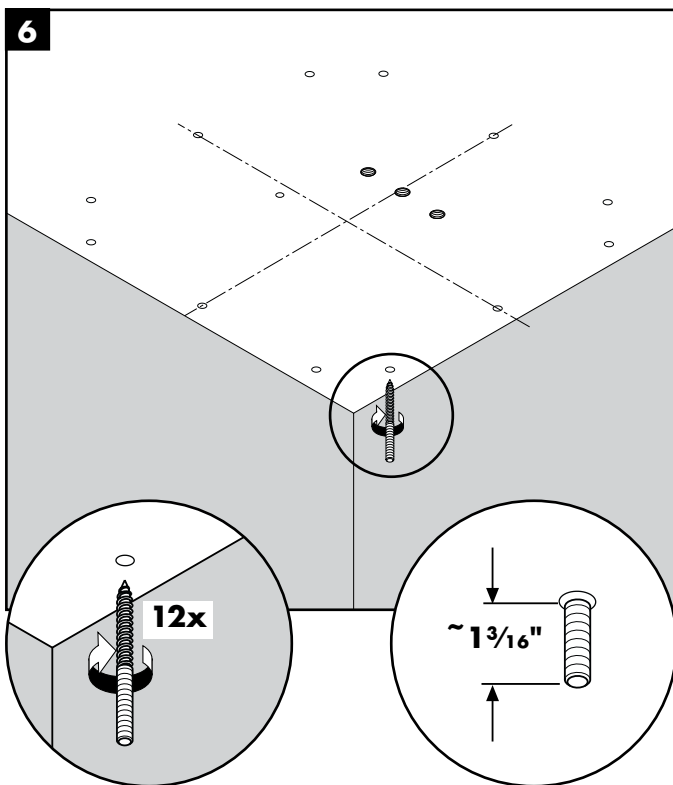

Install the screws.

The end of the screw should extend  $1 \frac{3}{16}$ " outside the finished surface of the ceiling.

Percez les trous de vissage à l'aide d'une mèche de 10 mm (1).  
Installez les chevilles (2). Scellez le plafond autour des chevilles  
à l'aide d'un agent d'étanchéité.

Perfore los orificios para los tornillos con una broca de 10mm.  
(1)

Instale los pernos de anclaje (2). Selle el cielo raso alrededor de  
los pernos de anclaje con un sellador impermeable.

Installez les vis.

Une partie de  $1\frac{3}{16}$  po de l'extrémité de la vis doit se trouver à  
l'extérieur de la surface finie du plafond.

Instale los tornillos.

El extremo del tornillo debe sobresalir  $1\frac{3}{16}$ " de la superficie  
terminada del cielo raso.

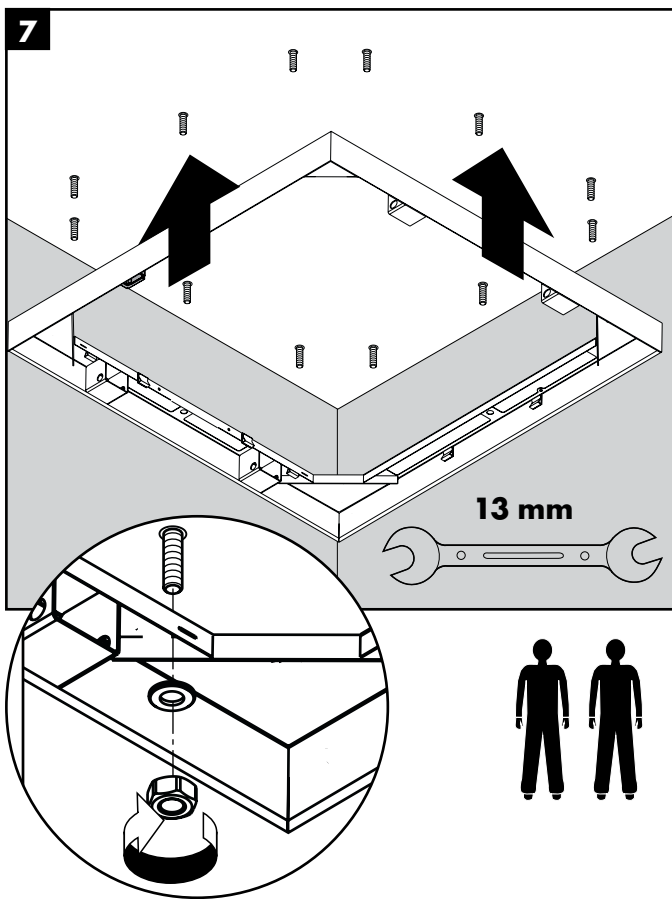

Position the frame over the screws.

Fasten the frame to the ceiling using the nuts and washers.

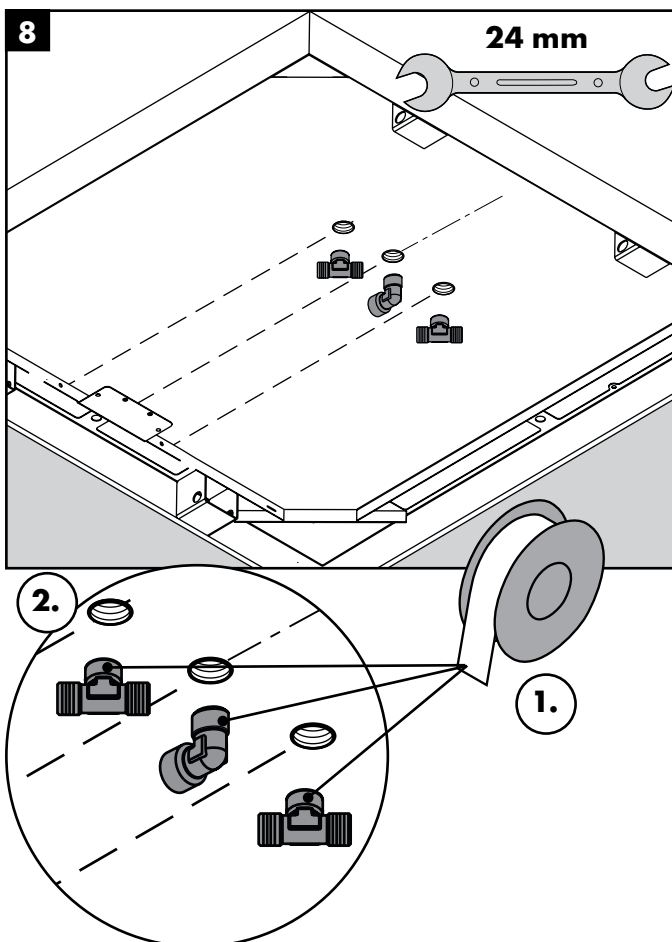

Wrap the threads on the supply elbow and tees using Teflon tape (1).

Install the supply elbow and tees (2).

Placez le cadre sur les vis.

Fixez le cadre au plafond en utilisant les écrous et rondelles.

Coloque el marco sobre los tornillos.

Fije el marco al cielo raso con las tuercas y las arandelas.

Enveloppez les filetages du coude d'alimentation et des raccords en T à l'aide de ruban de Téflon (1).

Installez le coude d'alimentation et les raccords en T (2).

Envuelva las roscas en el codo incluido y los tubos en "T" con cinta de Teflon (1).

Instale el codo incluido y los tubos en "T" (2).

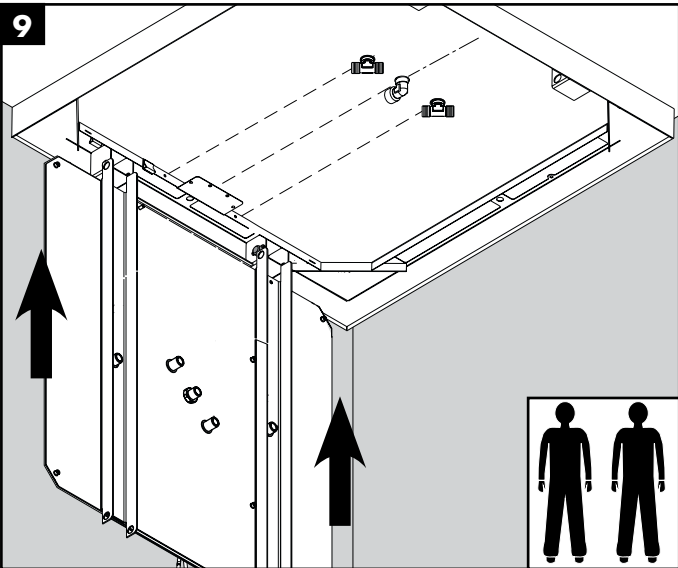

Position the body on the frame.

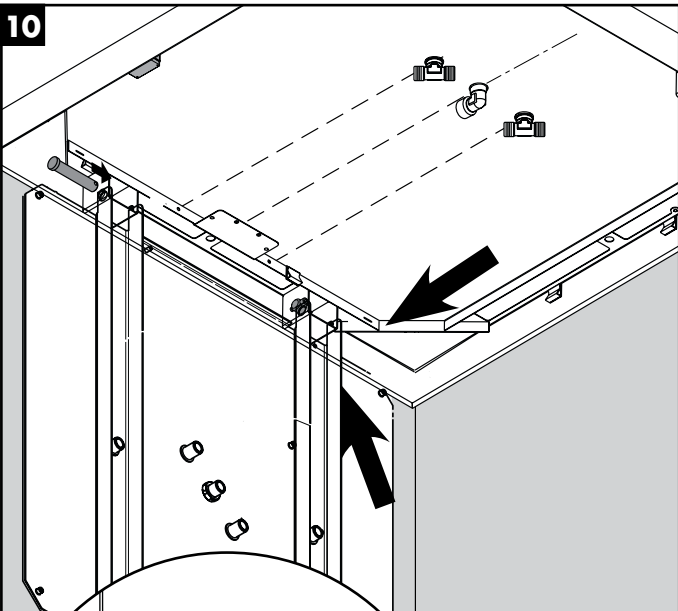

Install the hinge pins (1).

Install the screws (2).

5 mm



Placez la plaque sur le cadre.

Coloque el cuerpo en el marco.

Installez les broches de charnière (1).

Installez les vis (2).

Instale los pasadores de bisagra (1).

Coloque los tornillos (2).

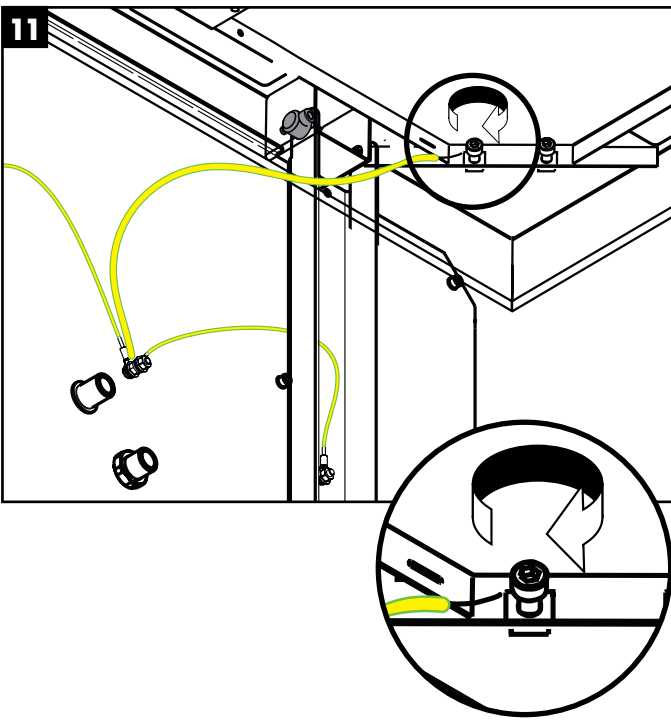

Reconnect the grounding wire.

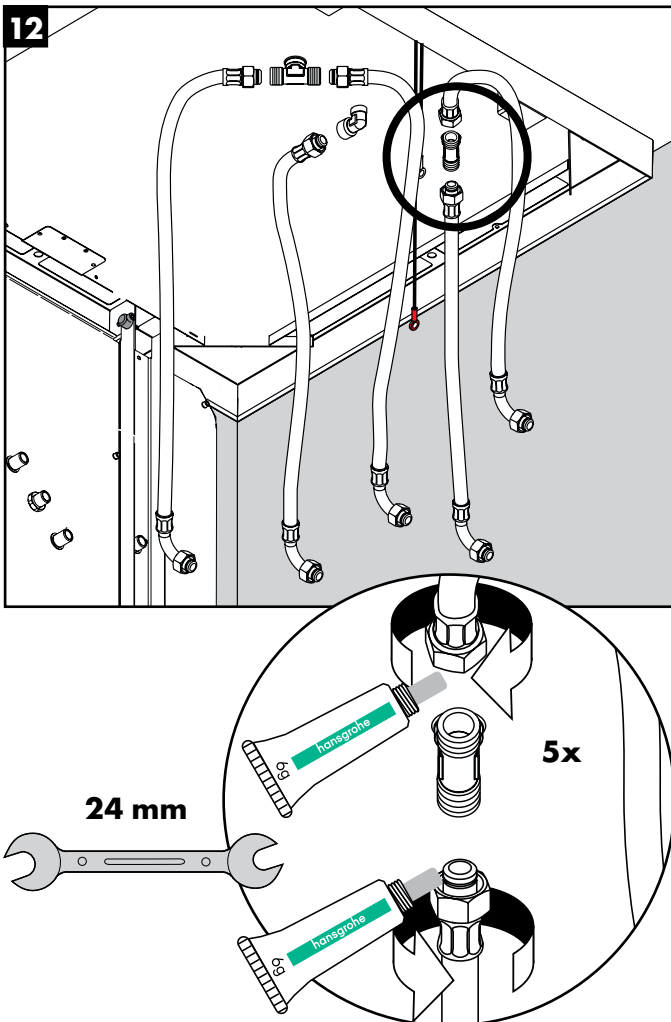

Lightly lubricate the hose connectors using the enclosed grease.  
Connect the hoses to the tees and elbow.

Installez le PE fil du cadre.

Conecte el alambre PE del marco.

Lubrifiez légèrement les raccords de tuyau à l'aide de la graisse fournie.

Raccordez les tuyaux aux raccords en T et au coude.

Lubrique ligeramente los conectores de la manguera con la grasa incluida.

Conecte las mangueras a los tubos en "T" y el codo.

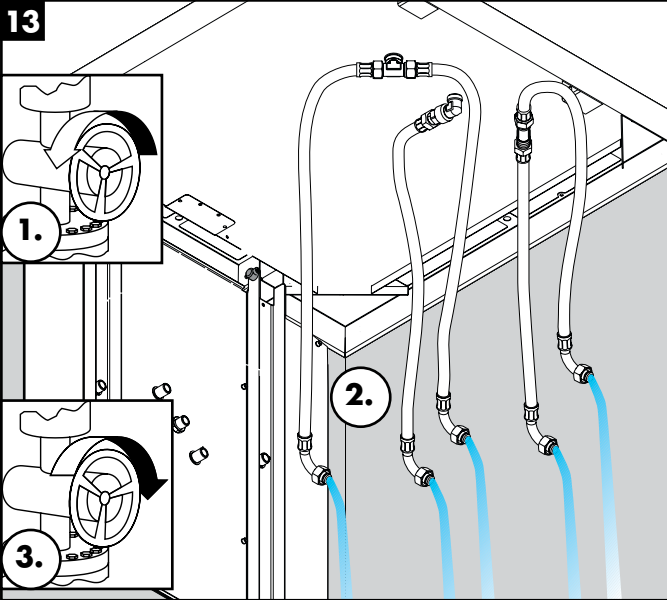

Turn on the water at the main (1).  
Flush the supplies and hoses (2).  
Turn the water off at the main (3).

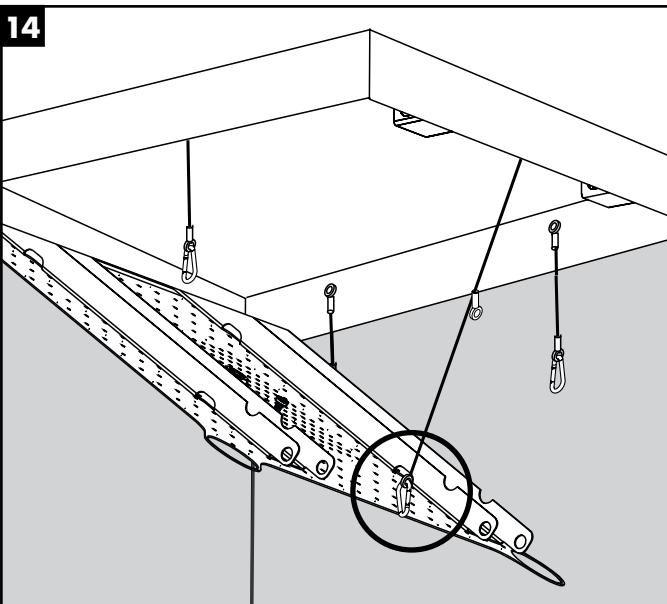

Install the longer safety strap onto the snap hook on the body.

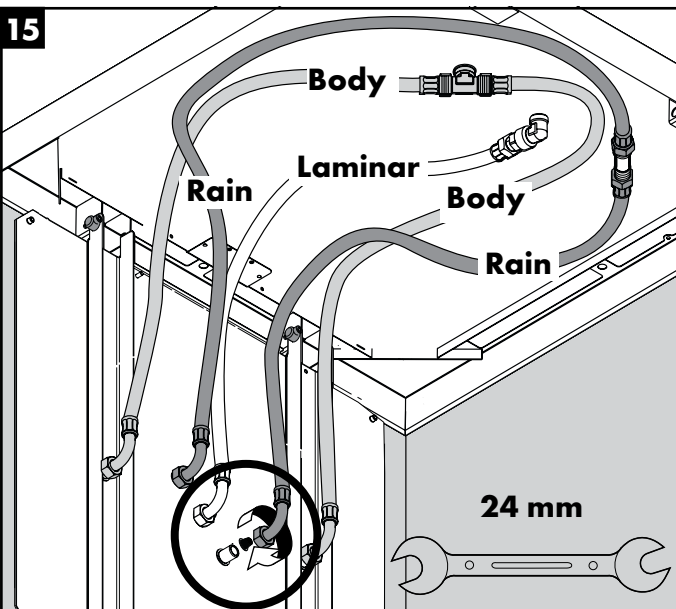
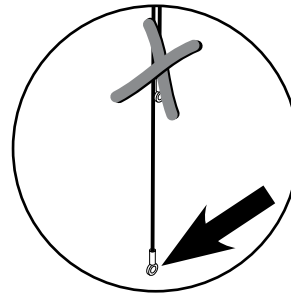

Install the filters in the body and rain spray hoses.. There is no filter in the laminar spray hose.  
Install the hoses on the spray body according to the illustrations.

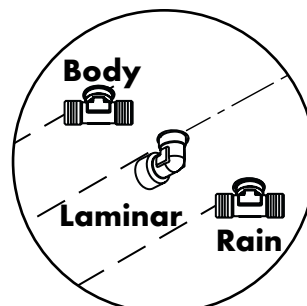

Ouvrez l'eau à la valve principale (1).  
Rincez les conduites et les tuyaux (2).  
Fermez l'eau à la valve principale (3).

Abra el paso del agua en la entrada del suministro (1).  
Lave las tuberías de suministro y las mangueras (2).  
Cierre el paso del agua en la entrada del suministro (3).

Installez la courroie de sûreté la plus longue sur le crochet de la plaque.

Instale el fleje de seguridad más largo en el gancho de presión en el cuerpo.

Installez les filtres dans la plaque et les tuyaux de jet de pluie. Le tuyau de jet laminaire ne contient aucun filtre.

Installez les tuyaux sur la plaque de jet en vous reportant aux illustrations.

Instale los filtros en el cuerpo y las mangueras de rociado de lluvia. No hay un filtro en la manguera de rociado en forma laminar.

Instale las mangueras en el cuerpo de rociado según las figuras.

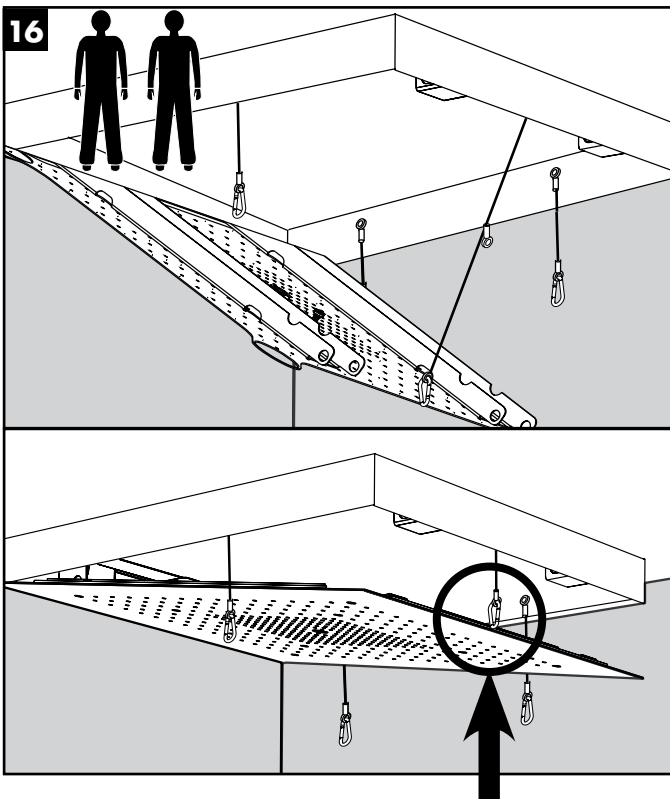

Connect the shorter safety strap to the snap hook.

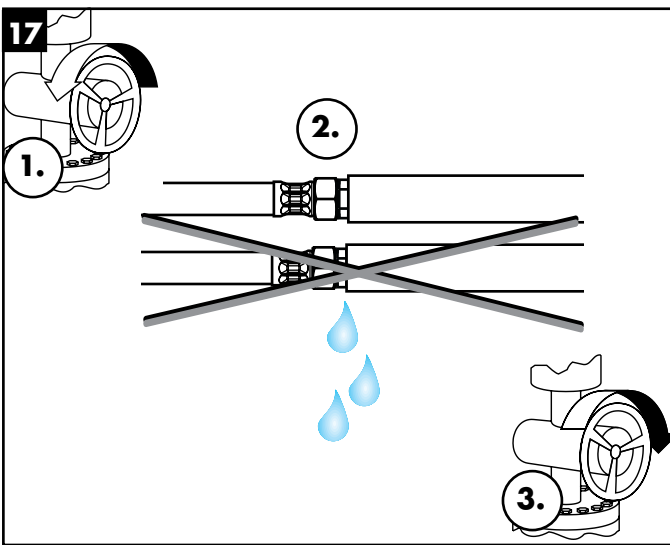
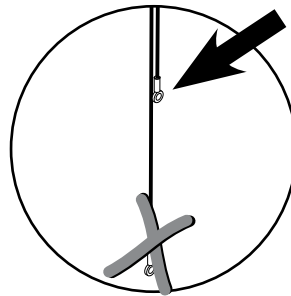

Turn on the water at the supply (1).  
Check the hose connections for leaks (2).  
Turn the water off at the main (3).

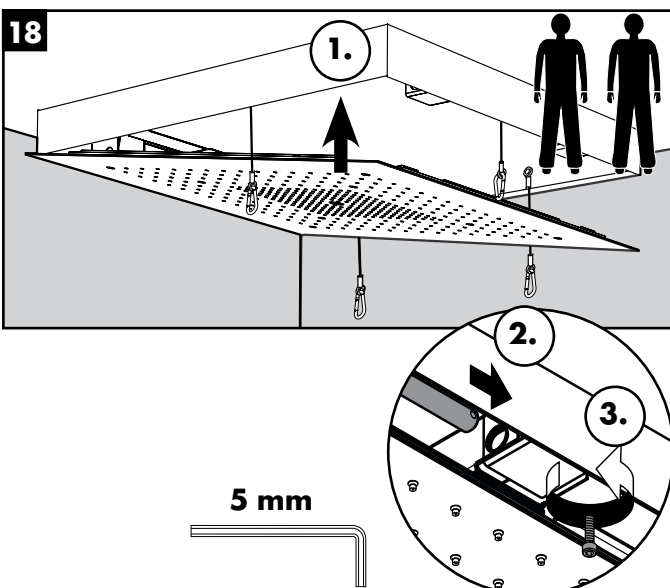

Position the body against the frame (1).  
Install the hinge pins (2).  
Install the screws (3).

Connectez la courroie de sûreté la plus courte au crochet.

Conecte el fleje de seguridad más corto al gancho de presión.

Ouvrez l'eau à la valve principale (1).

Vérifiez les raccords de tuyau pour vous assurer qu'il n'y a aucune fuite (2).

Fermez l'eau à la valve principale (3).

Abra el paso del agua en el suministro (1).

Verifique las conexiones de la manguera para asegurarse de que no haya pérdidas (2).

Cierre el paso del agua en la entrada del suministro (3).

Placez la plaque contre le cadre (1).

Installez les broches de charnière (2).

Installez les vis (3).

Coloque el cuerpo contra el marco (1).

Instale los pasadores de bisagra (2).

Coloque los tornillos (3).

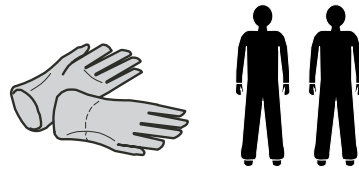
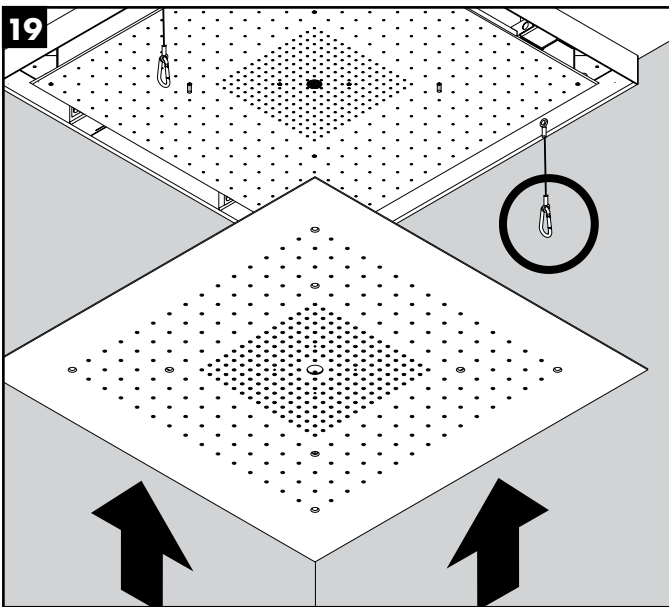

Connect the remaining three safety snap hooks to the face plate.

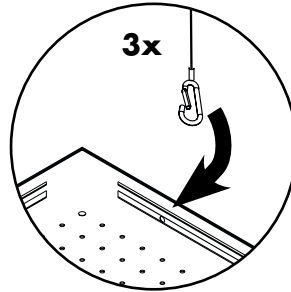

Install the four indicated screws using a 4 mm Allen wrench

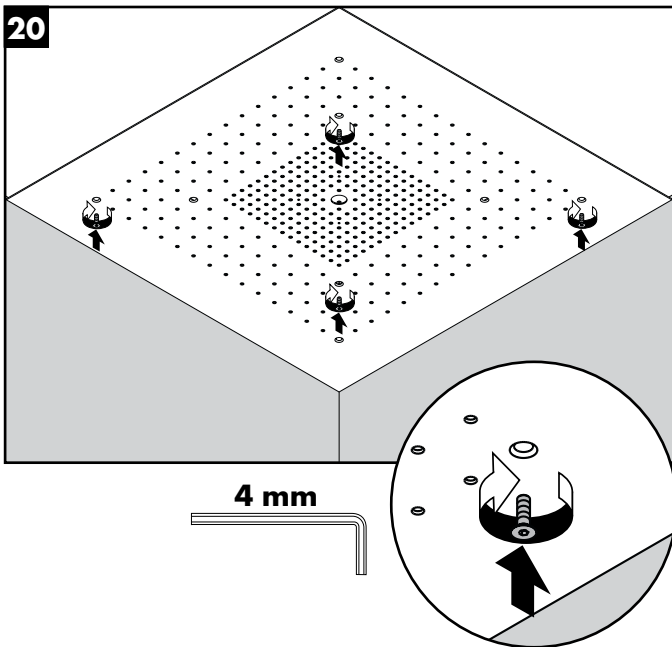

Remove the four studs (1).

Install the screws and tighten using a 4 mm Allen wrench (2).

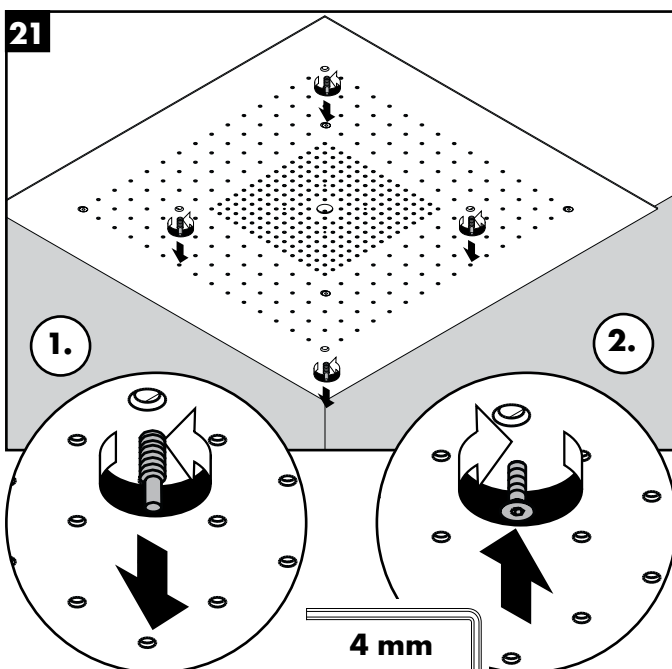



Connectez les trois crochets de sûreté restants à la plaque frontale.

Conecte los tres ganchos de presión de seguridad restantes en la placa frontal.

Installez les quatre vis indiquées à l'aide d'une clé hexagonale de 4 mm.

Instale los cuatro tornillos indicados con una llave Allen de 4 mm.

Retirez les quatre goujons (1).

Installez les vis et serrez-les à l'aide d'une clé hexagonale de 4 mm (2).

Retire los cuatro espárragos (1).

Instale los tornillos y apriételos con una llave Allen de 4 mm (2).

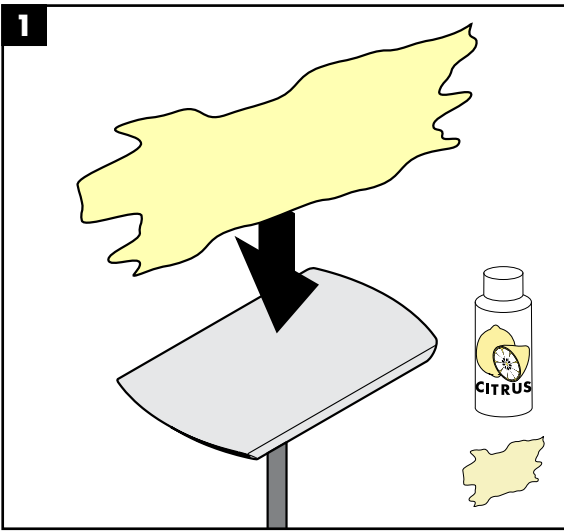

### Cleaning

Moisten a soft cotton cloth with a commercial scale remover such as CLR or LimeAway.

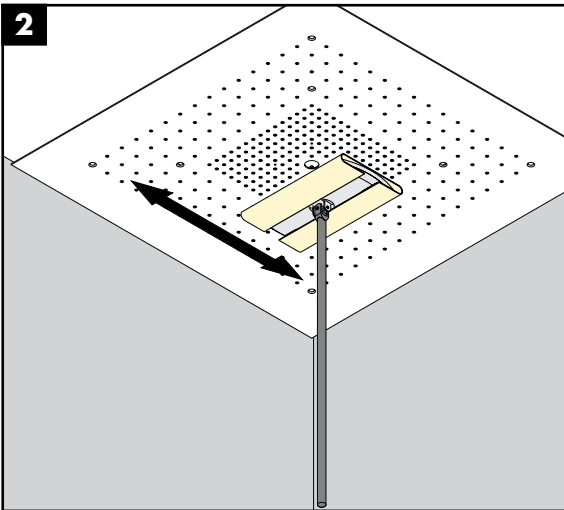

Wipe the faceplate using the cloth.

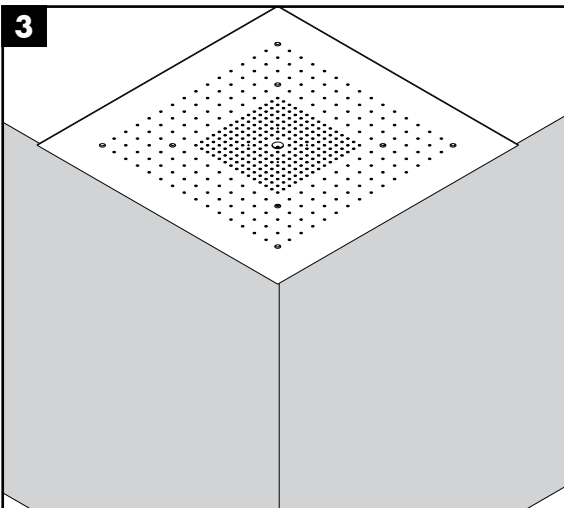

Allow the remover to remain on the face plate for the amount of time shown in the label instructions.

**Nettoyage**

Imbibez un chiffon en coton doux d'un produit détartrant commercial tel que CLR ou LimeAway.

Essuyez la plaque frontale avec le chiffon.

Laissez le détartrant sur la plaque frontale pour la durée indiquée dans les instructions de l'étiquette.

**Limpieza**

Humedezca un paño de algodón suave con un desincrustante comercial, como CLR o LimeAway.

Limpie la placa frontal con el paño.

Deje actuar al desincrustante sobre la placa frontal durante el tiempo indicado en las instrucciones de la etiqueta.

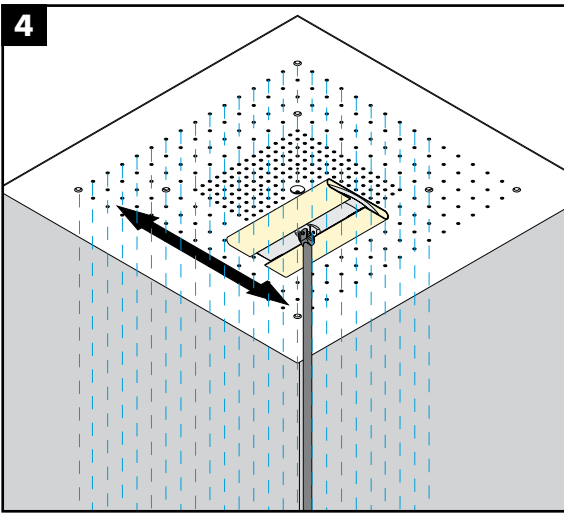

Turn the water on.

Wipe across the face plate using the cotton cloth.

Allow the ShowerHeaven to flush for at least 1 minute.

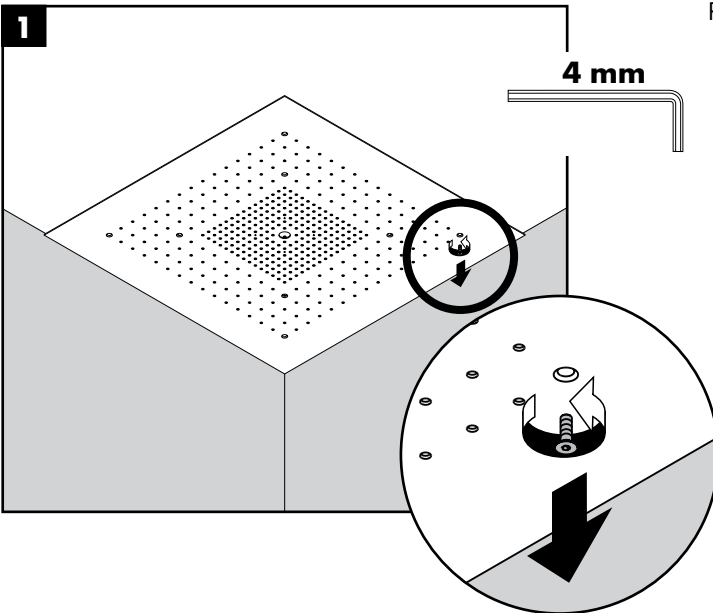

Remove the face plate screws.

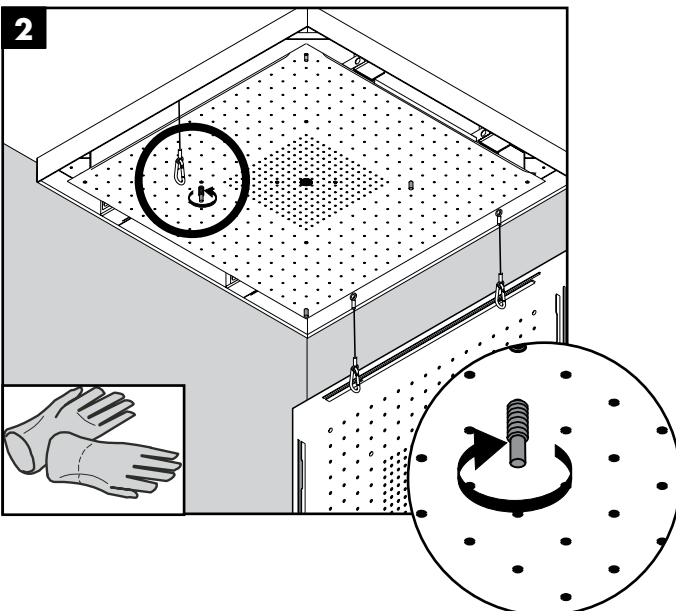

Install the studs as shown in the diagram.

Ouvrez l'eau.

Essuyez la plaque frontale d'un côté à l'autre avec le chiffon en coton.

Rincez le ShowerHeaven pendant au moins 1 minute.

Abra el suministro de agua.

Limpie toda la placa frontal con el paño de algodón.

Deje que la ShowerHeaven se lave durante 1 minuto como mínimo.

Retirez les vis de la plaque frontale.

Retire los tornillos de la placa frontal.

Installez les goujons de la façon indiquée dans le schéma.

Instale los espárragos como se muestra en el dibujo.

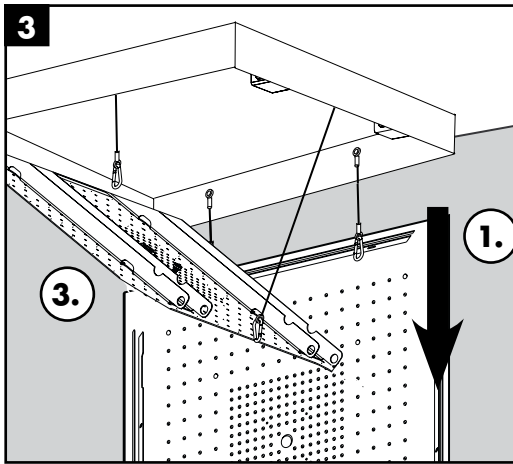

5 mm



Lower the face plate.

Remove two of the hinge screws and two of the hinge pins.

Lower the spray body.

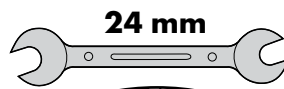
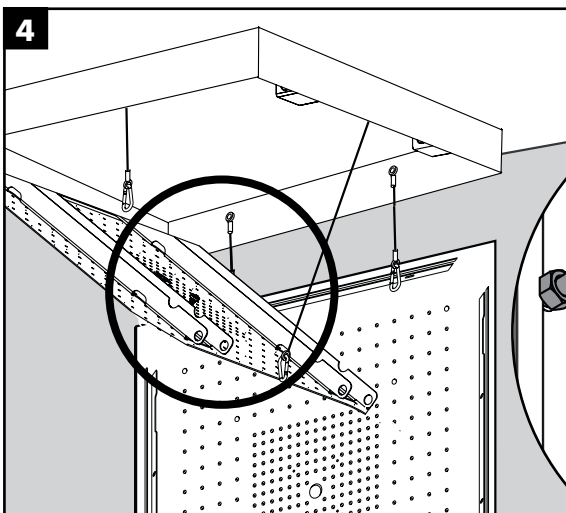
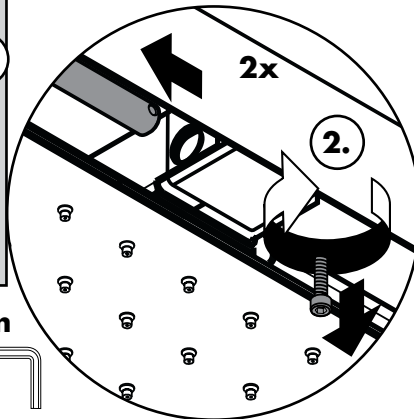

24 mm

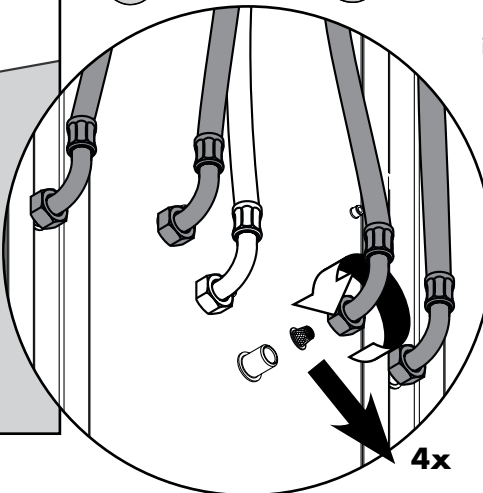

Disconnect the hoses from the spray body.

Remove the four filters (there is no filter in the laminar spray hose).

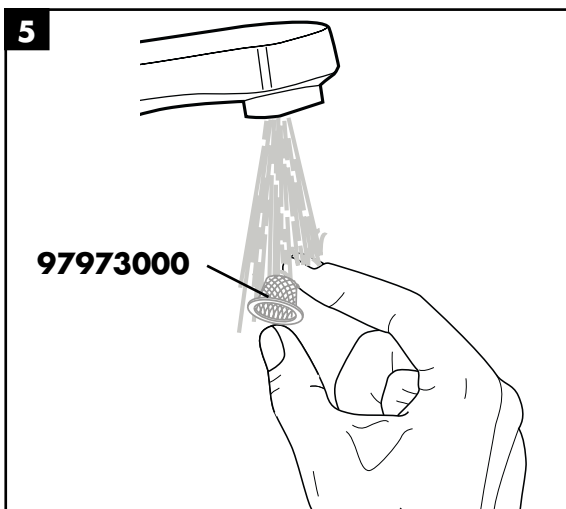

97973000

Flush the filters using clear water. Replace the filters if they are in poor condition.

Reassemble the ShowerHeaven in reverse order.

Abaissez la plaque frontale.

Retirez deux des vis de charnière et deux des broches de charnière.

Abaissez la plaque de jet.

Baje la placa frontal.

Retire dos de los tornillos de bisagra y dos de los pasadores de bisagra.

Baje el cuerpo de rociado.

Déconnectez les tuyaux de la plaque de jet.

Retirez les quatre filtres (le tuyau du jet laminaire ne contient aucun filtre).

Desconecte las mangueras del cuerpo de rociado.

Retire los cuatro filtros (no hay un filtro en la manguera de rociado en forma laminar).

Rincez les filtres à l'eau claire.

Réassemblez le ShowerHeaven dans l'ordre inverse.

Lave los filtros con agua limpia.

Vuelva a colocar la ShowerHeaven en orden inverso.

# Replacement Parts / Pièces détachées / Repuestos

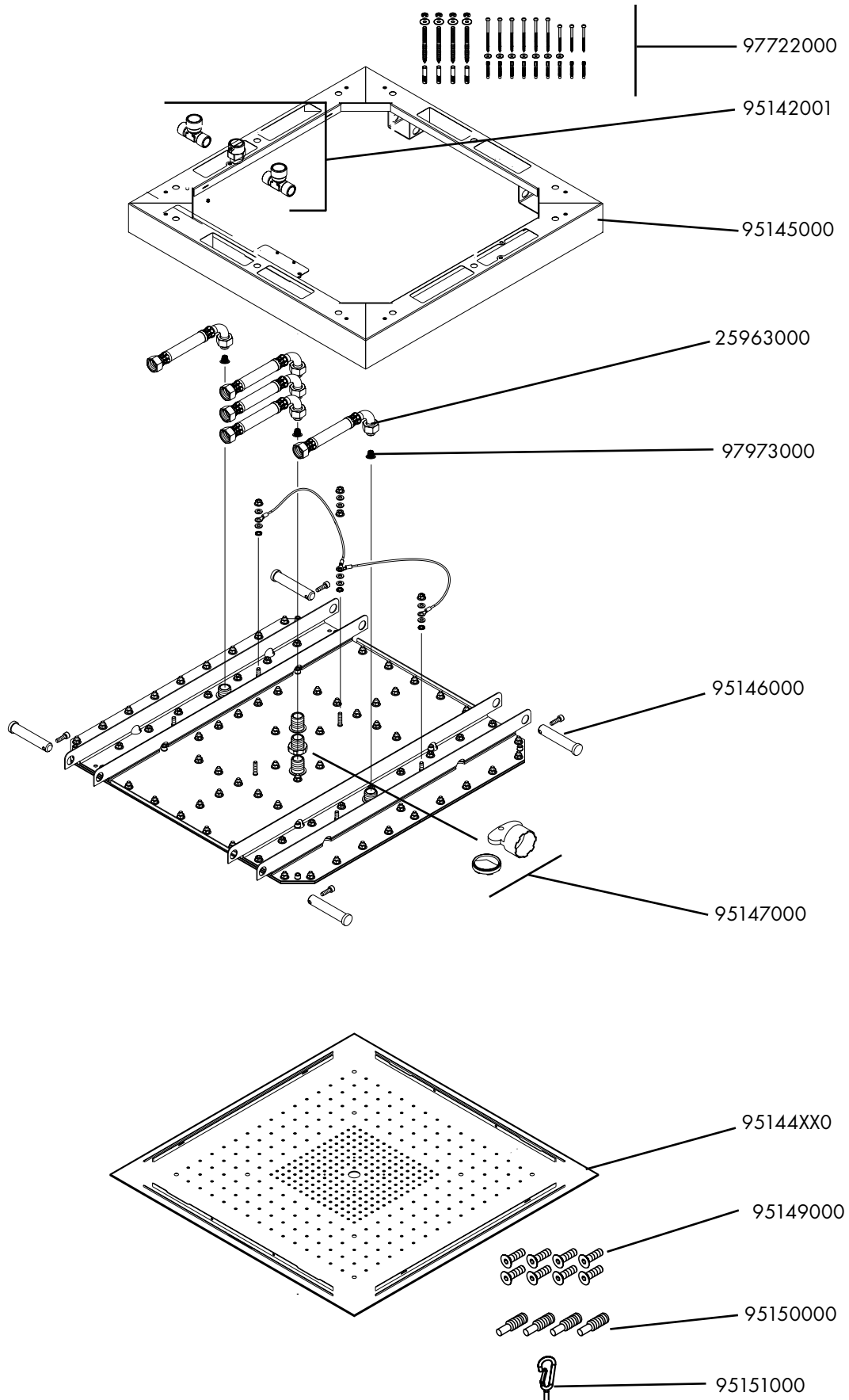

XX = colors / couleurs / acabados  
 80 = polished stainless steel  
 82 = brushed nickel



---

## Cleaning Recommendation for Hansgrohe Products

Modern lavatory faucets, kitchen faucets, and showers consist of very different materials to comply with the needs of the market with regard to design and functionality. To avoid damage and returns, it is necessary to consider certain criteria when cleaning.

### Cleaning Materials for Faucets and Showers

Acids are a necessary ingredient of cleaning materials for removing lime, however please pay attention to the following points when cleaning faucets and showers:

- Only use cleaning materials which are explicitly intended for this type of application.
- Never use cleaning materials which contain hydrochloric, formic, phosphoric, or acetic acid, as they cause considerable damage.
- Never mix one cleaning material with another.
- Never use cleaning materials or appliances with an abrasive effect, such as unsuitable cleaning powders, sponge pads, or micro fiber cloths.

### Cleaning Instructions for Faucets and Showers

Please follow the cleaning material manufacturer's instructions. In addition, pay attention to the following points:

- Clean the faucets and showers as and when required
- Use the amount of cleaning product and the amount of time recommended by the manufacturer. Do not leave the cleaner on the fixture longer than necessary.
- Regular cleaning can prevent calcification.
- When using spray cleaners, spray first onto a soft cloth or sponge. Never spray directly onto the faucet as droplets can enter openings and gaps and cause damage.
- After cleaning, rinse thoroughly with clean water to remove any cleaner residue.

### Important

Residues of liquid soaps, shampoos, and shower foams can also cause damage, so rinse with clean water after using.

**Please note:** if the surface is already damaged, the effect of cleaning materials will cause further damage.

**Components with damaged surfaces must be replaced or injury could result.**

**Damage caused by improper treatment is not covered under the warranty.**

## Recommandations pour le nettoyage des produits Hansgrohe

Les robinetteries modernes de lavabo, de cuisine et de douche utilisent des matériaux très différents pour répondre aux besoins du marché en termes de conception et de fonctionnalité. Certaines règles de base doivent être respectées lors du nettoyage de ces produits afin d'éviter de les endommager ou d'avoir à les retourner.

### Produits de nettoyage pour robinetteries et douches

Les acides sont une partie intégrante nécessaire de tous les produits de détartrage; il faut cependant prendre les précautions suivantes lors du nettoyage des robinets et des douches :

- N'utilisez que des produits/articles de nettoyage conçus spécifiquement pour les articles de robinetterie et de douche.
- N'utilisez jamais de produits/articles de nettoyage contenant de l'acide chlorhydrique, formique, phosphorique ou acétique car ils pourraient causer des dommages considérables.
- Ne mélangez jamais deux produits de nettoyage.
- N'utilisez jamais de produits/articles de nettoyage de nature abrasive tels que poudres de nettoyage, tampons-éponge ou chiffons microfibre non appropriés.

### Instructions de nettoyage pour robinetteries et douches

Veillez suivre les instructions du fabricant de produits/articles de nettoyage. De plus, tenez compte des conseils suivants :

Nettoyez vos produits de robinetterie et de douche aussi souvent que nécessaire.

- Utilisez la quantité de produit nettoyant et respectez la durée recommandée par le fabricant. Ne laissez pas le produit sur les articles de robinetterie plus longtemps que nécessaire.
- Un nettoyage régulier peut prévenir la formation de dépôts calcaires.
- Si vous utilisez des nettoyeurs en vaporisateur, vaporisez d'abord sur une éponge ou un chiffon. Ne vaporisez jamais directement sur un robinet : des gouttelettes pourraient s'infiltrer dans les ouvertures et les interstices et endommager celui-ci.
- Après le nettoyage, rincez abondamment avec de l'eau propre pour éliminer tout résidu de produit nettoyant.

### Important

Les résidus de savon liquide, de shampooing et de mousse pour la douche peuvent également endommager la robinetterie; rincez donc avec de l'eau propre après utilisation de ces produits.

**Veillez noter :** si la surface est déjà endommagée, les produits de nettoyage l'endommageront encore plus.

**Les composants dont la surface est endommagée devraient être remplacés sous peine d'entraîner des blessures.**

**Les dommages dus à un mauvais traitement ne sont pas couverts par la garantie.**

---

## Recomendación de limpieza para los productos de Hansgrohe

Hoy en día, las griferías de baño y de cocina así como duchas modernas se componen de materiales muy distintos para satisfacer las exigencias del mercado respecto al diseño y la funcionalidad. Para evitar daños reclamaciones hay que tener en cuenta ciertos aspectos tanto en el uso como en su limpieza posterior.

### Para el cuidado de las griferías y las duchas en principio hay que seguir lo siguiente:

- Usar sólo detergentes previstos específicamente para este campo de aplicación.
- No aplicar detergentes que contengan hipoclorito sódico, ácido clorhídrico, fórmico o acético porque pueden causar daños importantes.
- Detergentes que contienen ácido fosfórico tampoco pueden ser aplicados ilimitadamente.
- Por regla general no se deben mezclar detergentes.
- Tampoco se deben utilizar utensilios abrasivos, como son polvos abrasivos, esponjas o paños de microfibra.
- Si tienen que seguir siempre las instrucciones de uso de los fabricantes de los detergentes.
- La limpieza tiene que ser realizada según la dosificación y el tiempo de actuación, en función del objeto y ajustada a las necesidades específicas del mismo.
- Gracias a una limpieza periódica se pueden evitar las incrustaciones de cal.
- No conviene rociar el detergente en ningún caso sobre la grifería sino sobre los textiles y ejecutar la limpieza así porque el líquido puede entrar en aperturas o hendiduras de la grifería y causar daños.
- Después de la limpieza hay que aclarar con suficiente agua para eliminar completamente el resto de detergente.
- La utilización de limpiadores a vapor no está permitida, las altas temperaturas pueden dañar los productos.

### Indicaciones importantes

Los residuos de productos de aseo como jabón líquido, champús y gel de ducha pueden dañar también los materiales.

Por lo que también se deberá prestar atención a lo siguiente: aclarar con abundante agua después del uso.

Con materiales ya dañados la acción de detergentes incrementará el desgaste de estos.

**Los componentes con superficies dañadas deberán cambiarse, en otro caso se corre el peligro de lesionarse.**

**Los daños que resulten de un uso inadecuado no están incluidos en nuestra garantía.**

---

## Limited Lifetime Consumer Warranty

This product has been manufactured and tested to the highest quality standards by Hansgrohe, Inc. ("Hansgrohe"). This warranty is limited to Hansgrohe products which are purchased by a consumer in the United States after March 1, 1996, and installed in either the United States or Canada.

### WHO IS COVERED BY THE WARRANTY

This warranty extends to the original consumer purchaser only. This warranty is non-transferable.

### WHAT IS COVERED BY THE WARRANTY

This warranty covers only your Hansgrohe manufactured product. Hansgrohe warrants this product against defects in material or workmanship as follows: Hansgrohe will repair at no charge for parts only or, at its option, replace any product or part of the product that proves defective because of improper workmanship and/or material, under normal installation, use, service and maintenance. If Hansgrohe is unable to provide a replacement and repair is not practical or cannot be timely made, Hansgrohe may elect to refund the purchase price in exchange for the return of the product.

### LENGTH OF WARRANTY

Replacement or repaired parts of products will be covered for the term of this warranty as stated in the following two sentences. If you are a consumer who purchased the product for use primarily for personal, family, or household purposes, this warranty extends for as long as you own the product and the home in which the product is originally installed. If you purchased the product for use primarily for any other purpose, including, without limitation, a commercial purpose, this warranty extends only (i) for 1 year, with respect to Hansgrohe and Commercial products, and (ii) for 5 years, with respect to AXOR products.

### THIS WARRANTY DOES NOT COVER, AND HANSGROHE WILL NOT PAY FOR:

- A. Conditions, malfunctions or damage not resulting from defects in material or workmanship.
- B. Conditions, malfunctions or damage resulting from (1) normal wear and tear, improper installation, improper maintenance, misuse, abuse, negligence, accident or alteration, or (2) the use of abrasive or caustic cleaning agents or "no-rinse" cleaning products, or the use of the product in a manner contrary to the product instructions. (3) Conditions in the home such as excessive water pressure or corrosion.
- C. Labor or other expenses for the disconnection, deinstallation, or return of the product for warranty service, or for installation or reinstallation of the product (including but not limited to proper packaging and shipping costs), or for installation or reinstallation of the product.
- D. Accessories, connected materials and products, or related products not manufactured by Hansgrohe.

### TO OBTAIN WARRANTY PARTS OR INFORMATION

Contact your Hansgrohe retailer, or contact Technical Service at:

Hansgrohe Inc.  
1492 Bluegrass Lakes Parkway  
Alpharetta GA 30004  
Toll-free (800) 334-0455.

In requesting warranty service, you will need to provide

1. The sales receipt or other evidence of the date and place of purchase.
2. A description of the problem.
3. Delivery of the product or the defective part, postage prepaid and carefully packed and insured, to Hansgrohe Inc. 1492 Bluegrass Lakes Parkway, Alpharetta, Georgia 30004, Attention: Technical Service, if required by Hansgrohe.

When warranty service is completed, any repaired or replacement product or part will be returned to you postage prepaid.

### EXCLUSIONS AND LIMITATIONS

REPAIR OR REPLACEMENT (OR, IN LIMITED CIRCUMSTANCES, REFUND OF THE PURCHASE PRICE) AS PROVIDED UNDER THIS WARRANTY IS THE EXCLUSIVE REMEDY OF THE PURCHASER. HANSGROHE NEITHER ASSUMES NOR AUTHORIZES ANY PERSON TO CREATE FOR IT ANY OBLIGATION OR LIABILITY IN CONNECTION WITH THIS PRODUCT.

HANSGROHE SHALL NOT BE LIABLE TO PURCHASER OR ANY PERSON FOR ANY INCIDENTAL, SPECIAL, OR CONSEQUENTIAL DAMAGES, ARISING OUT OF BREACH OF THIS WARRANTY OR ANY IMPLIED WARRANTY (INCLUDING MERCHANTABILITY).

Some States do not allow the exclusion or limitation of incidental or consequential damages, so the above limitation or exclusion may not apply to you. This warranty gives you specific legal rights, and you may have other rights which vary from State to State. You may be required by law to give us a reasonable opportunity to correct or cure any failure to comply before you can bring any action in court against us under the Magnuson-Moss Warranty Act.

### PRODUCT INSTRUCTIONS AND QUESTIONS

Upon purchase or prior to installation, please carefully inspect your Hansgrohe product for any damage or visible defect. Prior to installing, always carefully study the enclosed instructions on the proper installation and the care and maintenance of the product. If you have questions at any time about the use, installation, or performance of your Hansgrohe product, or this warranty, please call or write to us or call us toll-free at 800 334 0455.



Hansgrohe, Inc. • 1490 Bluegrass Lakes Parkway • Alpharetta, GA 30004  
Tel. 770-360-9880 • Fax 770-360-9887

[www.hansgrohe-usa.com](http://www.hansgrohe-usa.com)