



10-3305
MOBIUS CHANDELIER

As shown: 10-3305-07

All designs and images ©1989-2012 Hubbardton Forge®. All rights reserved.

HUBBARDTON FORGE®

HUBBARDTONFORGE.COM

IO-3305
MOBIUS

Chandelier with six arms.

Chain-hung

Dimensions

Height	31"
Diameter	24.6"
Canopy Can	5.0" OD
Wire/Chain Included	17' / 3'

Max Hanging Weight

9.4 lbs

Incandescent Lamping

Socket: (6) G-9 halogen
Bulb (Included): G-9 Shielded, 25 watt max

UL Listing

Suitable for damp locations



Updated 12.11

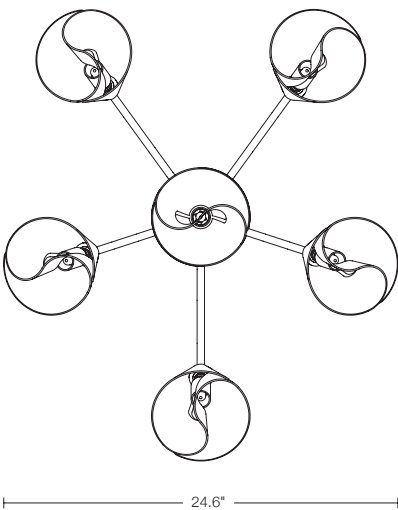
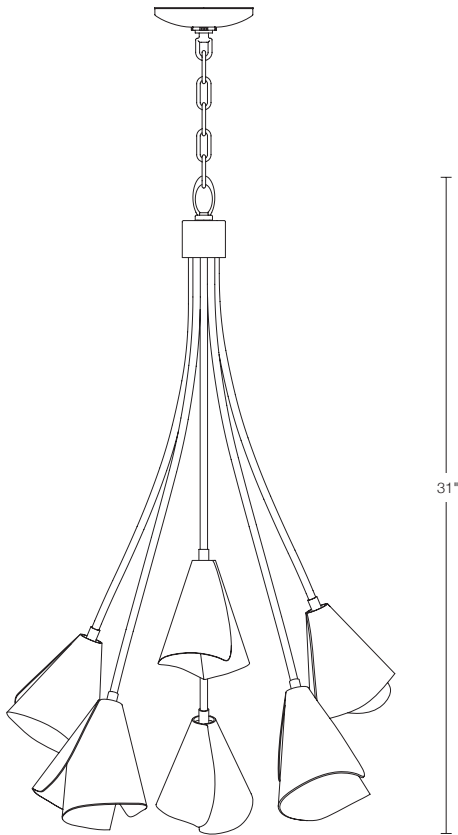

HUBBARDTON FORGE®



HUBBARDTONFORGE.COM

FOR MORE INFORMATION CALL CUSTOMER SERVICE AT 800-826-4766
OR EMAIL CUSTOMERSERVICE@VTFORGE.COM FOR RESIDENTIAL;
CONTRACT@VTFORGE.COM FOR COMMERCIAL.

154 RT. 30 SOUTH · CASTLETON, VERMONT 05735 · T 800-826-4766 · F 877-910-3700

All designs and images ©1989-2012 Hubbardton Forge®. All rights reserved.