

Assembly & Installation Instructions

A311

Brindille Adjustable Pendant 13-7665

Page 1 of 4

CAUTION: FAILURE TO INSTALL THIS FIXTURE PROPERLY MAY RESULT IN SERIOUS PERSONAL INJURY OR DEATH AND PROPERTY DAMAGE. We recommend installation by a licensed electrician.

This product must be installed in accordance with applicable installation code(s), by a person familiar with the construction and operation of the product and the hazards involved.*

Caution: Do not exceed maximum wattage noted on fixture. Use only recommended bulbs with fixture.

Prepare the Canopy (Figure 1)

Component Parts

- A Crossbar
- B Jam Nut (2)
- C Threaded Nipple
- D Canopy
- E Canopy Ring

Caution: Be sure power is off at the main breaker box prior to installation.

1. Thread jam nuts (B) and crossbar (A) onto threaded nipple (C); leave parts loose.
2. Using two machine screws (not provided), temporarily fasten the crossbar (A) to the electric box. **Note: A new electric box comes with screws. When replacing a fixture, retain the existing screws for use with the new fixture.**
3. Adjust the length of threaded nipple (C) in crossbar (A) so that canopy ring (E) will hold canopy (D) against the ceiling with no threads showing for best appearance. When the correct adjustment is established, tighten jam nuts (B) against crossbar (A) to hold the adjustment.
4. Remove the crossbar and stem from the electrical box and proceed with the assembly instructions.

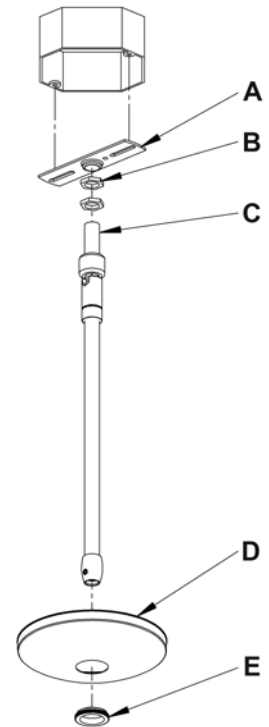

(Figure 1)

Complete Assembly & Install Fixture (Figures 2 & 3)

Component Parts

- A Crossbar
- D Canopy
- E Canopy Ring
- F Canopy Pipe
- G Plastic Sleeve
- H Clutch
- I Set Screw
- J Fixture Pipe

Caution: Be sure power is off at the main breaker box prior to installation.

1. Place canopy (D) over canopy pipe (F), followed by canopy ring (E). Make sure smaller diameter side of canopy ring is oriented up toward the canopy.

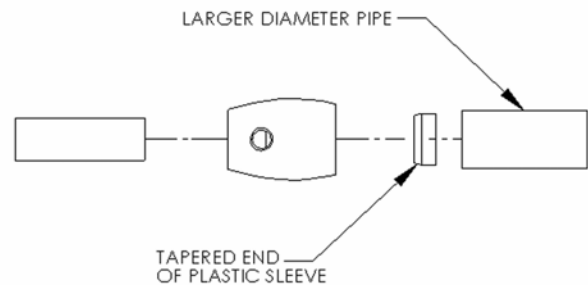

(Figure 2)

(continued)

Assembly & Installation Instructions

A311

Brindille Adjustable Pendant 13-7665

Page 2 of 4

2. Thread wires from the fixture pipe (J) through the canopy pipe (F).
3. Unscrew the clutch (H) from the canopy pipe (F); slide it across the wires and onto the fixture pipe (J). Follow this with the plastic clutch sleeve (G), oriented so the tapered end of the clutch sleeve nests in the clutch (Figure 3).
4. Slide the canopy pipe (F) as far as necessary to give you the total length of the fixture which you desire. Be careful not to scratch the pipe surfaces and to pull excess wire up through the canopy pipe (F). There must be a minimum 1-1/2" of inner pipe inside the outer pipe. Hand-tighten the clutch to temporarily hold this adjustment. The clutch is not securely fastened at this point; do not depend on it to hold the fixture.
Important: To ensure full connection strength, be sure the tapered end of the plastic clutch sleeve is oriented toward the clutch when assembled and securely tighten set screw (Figure 3).
5. Carefully slide canopy ring (E) and canopy (D) down over fixture pipe (J) until they rest on the fixture.
6. Using two machine screws (not provided), fasten the crossbar to the electric box.
Note: A new electric box comes with screws. When replacing a fixture, retain the existing screws for use with the new fixture.
7. Using suitable wire connectors (not provided), connect fixture wires to supply wires (white to white supply, black to black supply, and bare copper to bare copper or green supply). Connect all ground wires to green ground screw. Push wires back into outlet box.
Caution: Make sure wire connectors are twisted on securely, and no bare wire is exposed.
8. Slide fixture canopy (D) against ceiling, and secure with canopy ring (E).
9. Once the fixture is fastened to the ceiling, tighten the set screw (I) firmly with hex wrench provided. Only after the set screw (I) is tight should you install the glass.
10. Refer to instructions below to install shade and bulb(s).

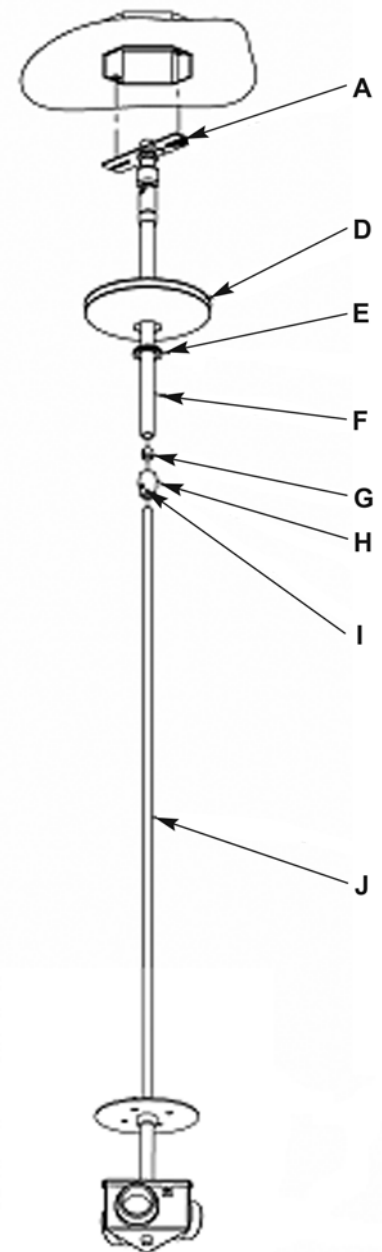

(Figure 3)

(continued)

Assembly & Installation Instructions

Brindille Adjustable Pendant 13-7665

A311

Page 3 of 4

Install Bottom Diffuser & Lower Assembly (Figures 4, 5 & 6)

Component Parts

- K ¼-20 Nut (3)
- L Spider
- M Bottom Diffuser
- N Lower Assembly
- O Threaded Nipple
- P Cap

1. Tilt and lift shade up over socket and large washer.
Note: *It may be helpful to secure shade to canopy pipe (J) to simplify the next assembly steps.*
2. Remove ¼-20 nuts (K) and spider (L) from the lower assembly (N) and set aside.
3. Align holes in diffuser (M) with the three studs on the lower assembly (N). Lower diffuser until it sits on the washer of the lower assembly (N) (Figure 5).
4. Replace Spider (L) and ¼-20 nuts (K) and tighten.
5. Align center hole in the lower assembly (N) with the threaded nipple (O) (Figure 6).
6. While holding lower assembly (N) over the threaded nipple (O), twist cap (P) onto the nipple and tighten.

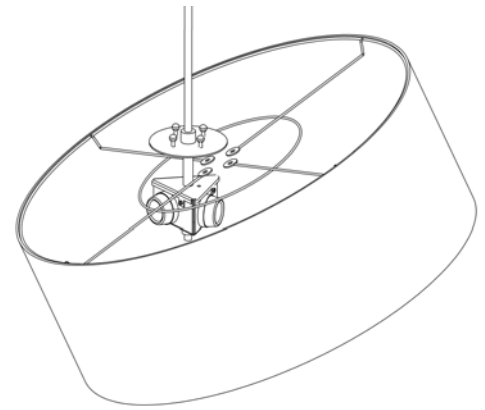

(Figure 4)

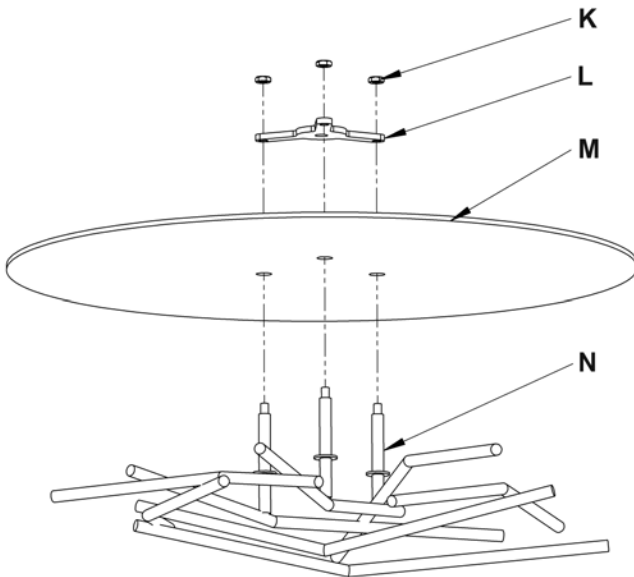

(Figure 5)

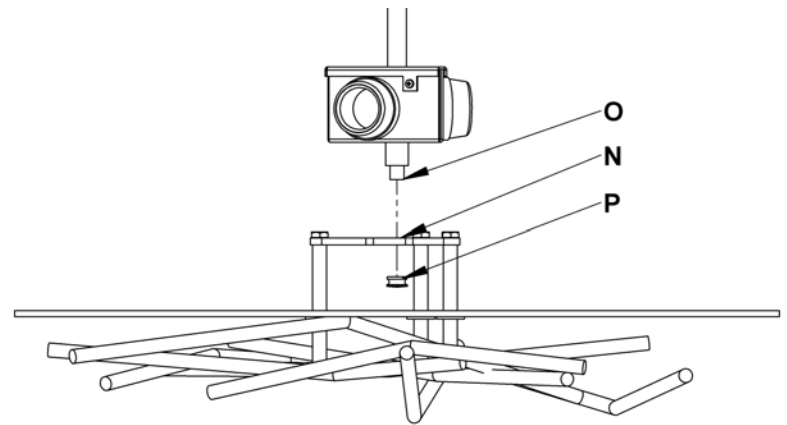

(Figure 6)

(continued)

Install Shade & Top Diffuser (Figure 4)

Component Parts

- Q Knurled Ball (4)
- R Top Diffuser (2)
- S Shade

1. Install light bulbs
2. Lower shade (S) so the four washers slide down over the threaded studs.
3. Place diffusers (R) on top of shade and also aligning threaded studs with holes in the glass
4. Using the four knurled balls (Q), tighten the diffuser until it is snug.
5. Restore electricity at the main breaker.

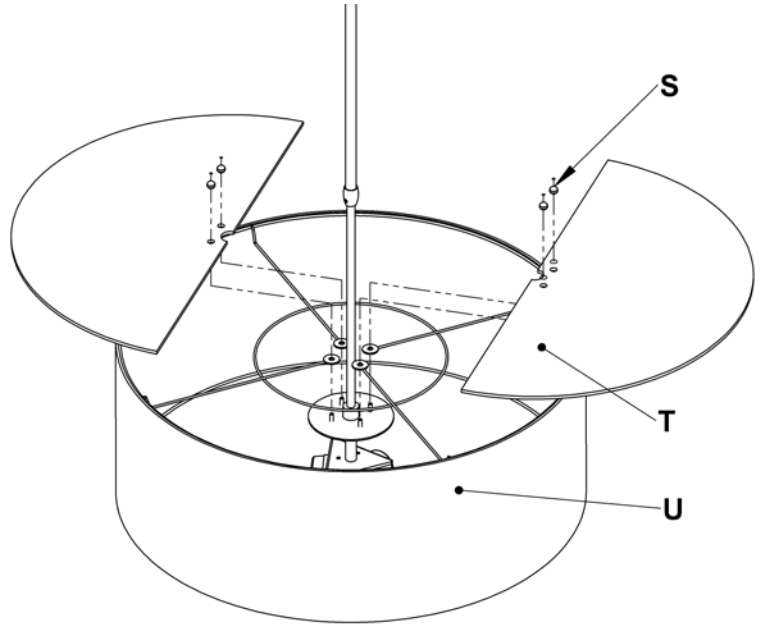

(Figure 7)

If you need further assistance, or find that you are missing any parts, please contact the dealer from which you purchased this product. We hope you enjoy your fixture!

* Hubbardton Forge will not be liable for injury or damage caused by improper installation, lamping or use of this fixture.