



Features

- ◆ **Lighting:** Lighting uses 50 Watt Halogen Spots (PAR20). (Bulbs NOT Included)
- ◆ **Filters:** Stainless Steel Baffle.
- ◆ **Custom:** Custom sizes available. Call with exact dimensions for pricing and delivery time.
- ◆ **Optional Duct Cover:** Made to your specification. Provide HEIGHT and WIDTH.
- ◆ **Optional Remote Controls:** Remote control wiring available.

Specifications

- ◆ **Power:** Flame Retardant Centrifugal Blowers.
 WH1900PSB-32-K has dual blowers = 1000 CFM.
 WH1900PSB-TW32-K has four blowers = 1675 CFM.
- ◆ **Stainless Steel:** Complete **304 Marine Grade, 18 Gauge Stainless Steel** Construction for Durability and Fire Safety.
- ◆ **Distance Codes:** Check local city, county and cooking appliance specifications. UL tested at 36” above cooking surface. Run duct pipe at least 24” straight up before making any elbows for best performance. Elbows will reduce CFM.

Warranty

- ◆ **Warranty:** 7 Year, In-Home—Parts & Labor on manufacturer defects. **(Best in the Industry!)** Performance not included.

MODELS	POWER CFM	MOTOR TYPE	CONTROLS	SONES LOW-HI	DEPTH	DUCT	SIZES
WH1900PSB-32-K	1000	Dual Blowers	2 Variables	2.5 - 4.9	32”	Single 10”	36”, 42”, & 48”
WH1900PSB-TW32-K	1675	Two Dual Blowers	3 Variables	2.5 - 4.9	32”	Two 10”	54” & 60”



Wall Mount Specifications

NOTE: 10" round transition attached to duct opening.



10" Round x 7-1/2" High

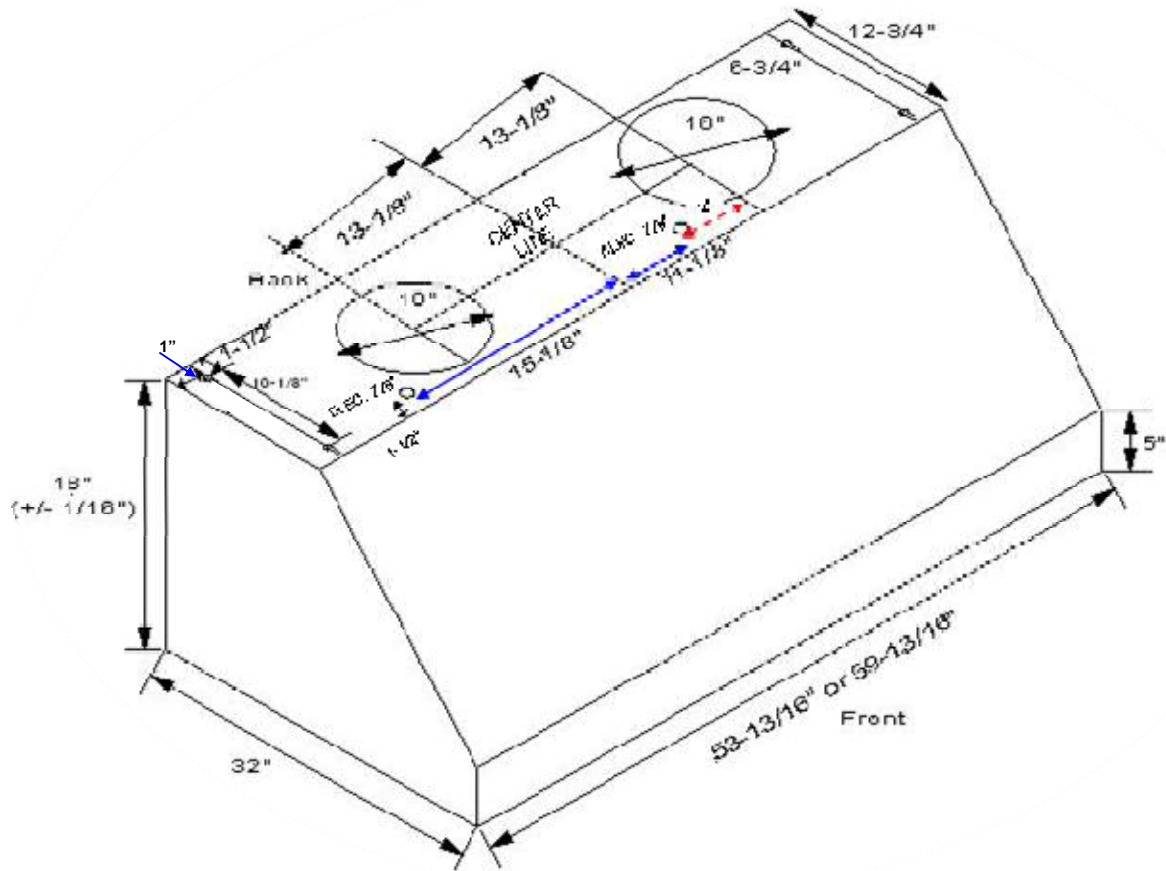
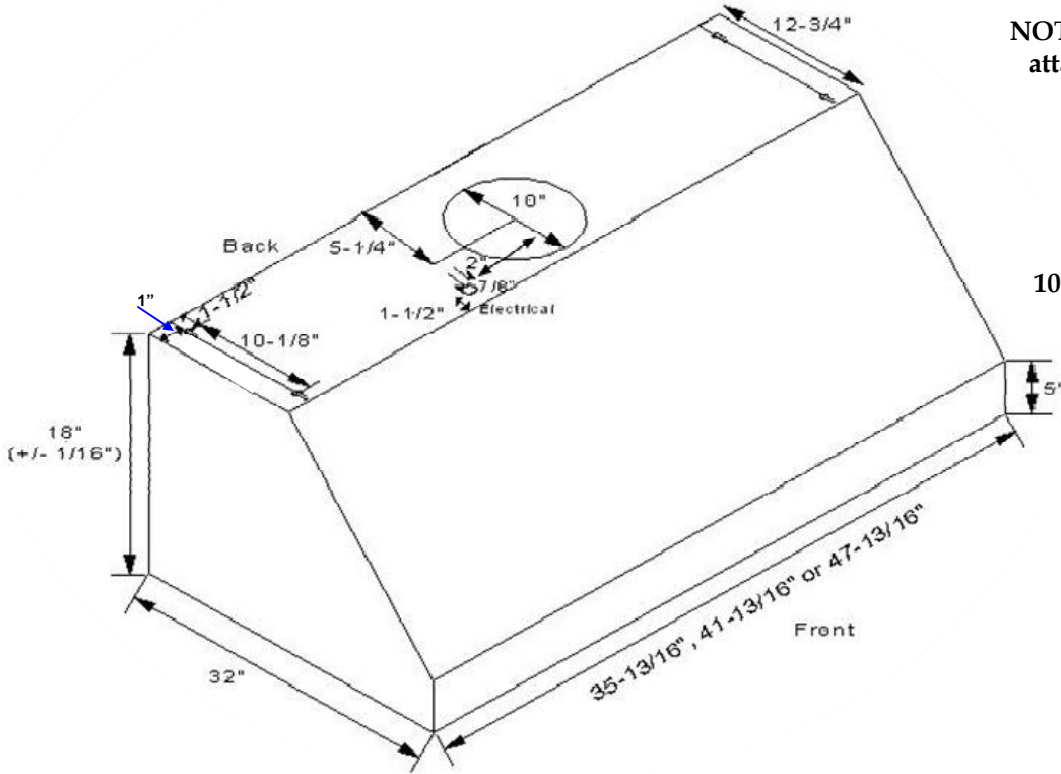

All dimensions are (+/-) 1/8" and are subject to change. Drawings are not to scale.

