

JADO

Pressure Balanced Shower and Valve Set **Installation Instructions**

To ensure that your installation proceeds smoothly--please read these instructions carefully before you begin.

P r o d u c t s

L u x u r y F a u c e t s a n d A c c e s s o r i e s

Savina

Product Numbers

845/485/...

845/486/...



JADO USA
6615 West Boston
Chandler, AZ 85226
Phone: (800) 227-2734
Fax: (800) 552-JADO (5236)
www.jadousa.com

RECOMMENDED TOOLS

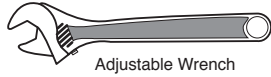

Adjustable Wrench

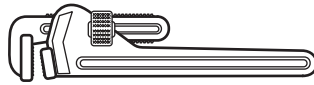

Pipe Wrench

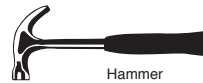

Hammer



Teflon Tape

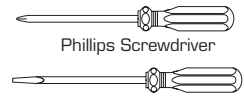

Phillips Screwdriver



Regular Screwdriver

ROUGHING-IN DIMENSIONS

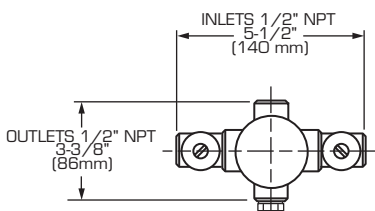
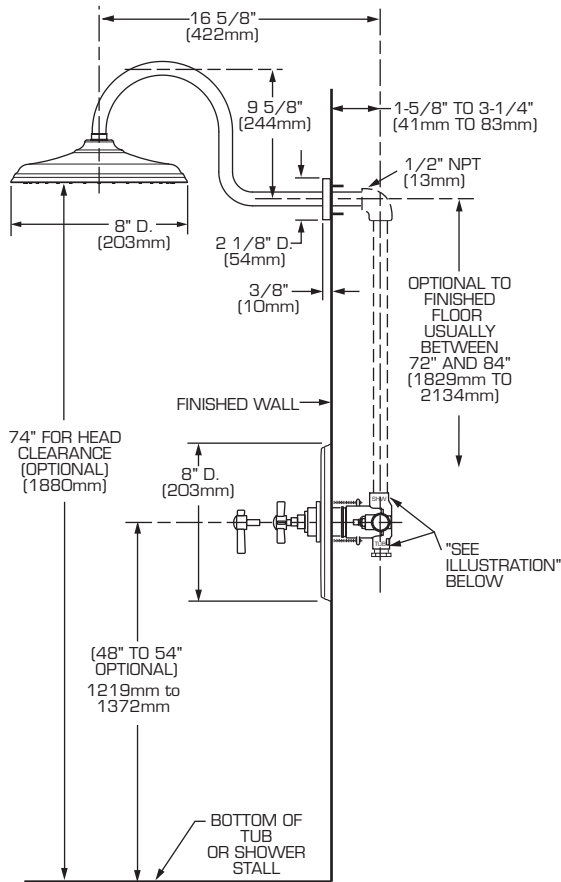

THREADED INLETS (STOPS)

1

ROUGHING-IN CAUTION Turn off water at main supply.

NOTE When soldering, remove **PLASTER GUARD, CARTRIDGES** and **CHECK STOPS (IF PRESENT)**. When finished soldering, flush valve body, replace cartridges, check stops (if present) and plaster guard to continue installation. Use thread sealant or Teflon tape on threaded connections.

- See Roughing-in diagram before starting.
- Connections are:
 - 1/2" female NPT for threaded inlets
- Connect **RISER PIPE (1)** to **MANIFOLD (2)** top outlet marked "SHR".
- For proper positioning the finished wall must be within side wall of **PLASTER GUARD (3)**. Secure valve body to wall support.
- If the valve is installed on a fiberglass or other thin wall application, the **PLASTER GUARD (3)** can be used as a support.
 - Cut a 4" dia. hole in the shower stall.
 - Drill two additional 1" holes to allow access to the stops.
 - Remove **PLASTER GUARD (3)**, rotate 180° so that indicated screw holes fit **MANIFOLD (2)**. Push **CAP (4)** on valve, place **ESCUTCHEON** on and attach with screws.
- Connect hot and cold water supplies.
- Cap off shower pipe **(5)**.
- For support, use pipe **BRACES (6)** secured to wooden braces.
- With valve turned off, turn on water supplies. Check for leaks.

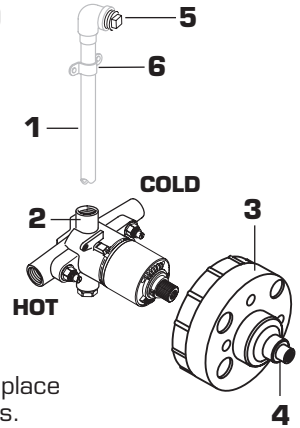

2

INSTALL VALVE COVER

- When finished tiling the wall, remove **PLASTER GUARD (1)**.
- Push **CAP (2)** over **VALVE CARTRIDGE (3)** until seated against stop. (Spline in **CAP (2)** must fully engage spline on cartridge stem).

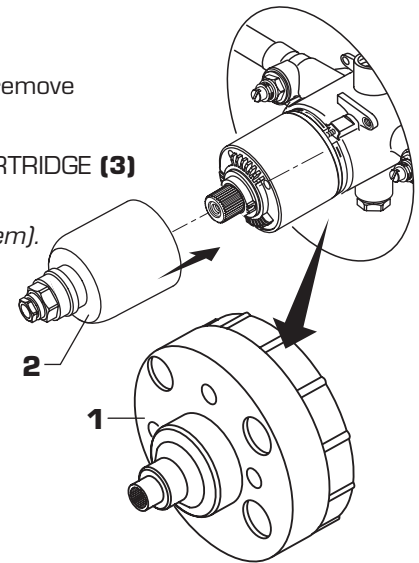

3

INSTALL TRIM

- Install **ESCUTCHEON (1)** onto **CAP (2)** and push flush against finished wall.
- Align mounting holes in **ESCUTCHEON (1)** with with threaded mounting holes in valve body.
- Secure **ESCUTCHEON (1)** with **SCREWS (3)**.
- Push **DIAL PLATE (4)** onto **CAP (2)**.

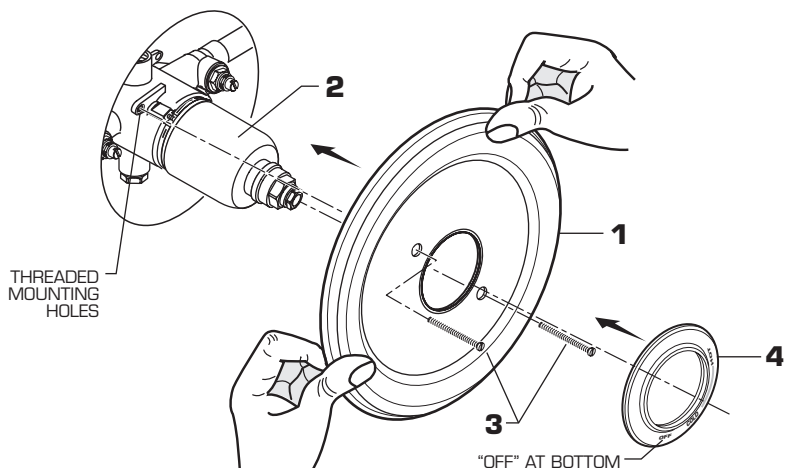

4 INSTALL TRIM

- Remove PIPE PLUG (1) from shower pipe.
- Apply sealing tape to both ends of SHOWER ARM (2). Install SHOWER ARM (2) and RAIN SHOWER HEAD (3).

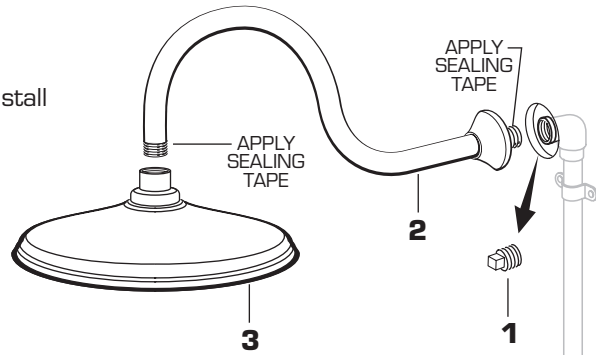

CAUTION: Protect finish on SHOWER ARM, SHOWER HEAD when installing.

4a INSTALL HANDLE (ADJUST HOT LIMIT STOP PRIOR TO HANDLE INSTALLATION, SEE STEP 5.)

For Cross and Lever Handles:

- Align and install LEVER HANDLE (4) or CROSS HANDLE (5) into VALVE STEM (6) and secure with SCREW (7).
- Push INDEX BUTTON (8) into HANDLE (4) or (5).

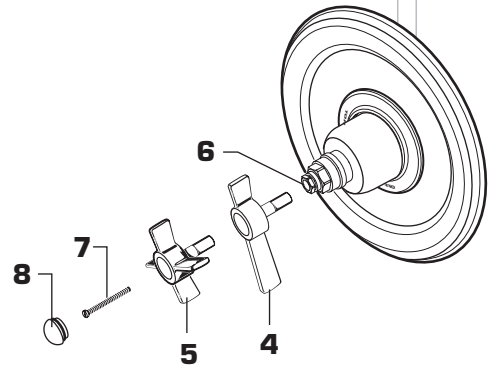

5 ADJUST HOT LIMIT STOP (MUST BE DONE WITH TRIM REMOVED)

By restricting HANDLE rotation and limiting the amount of hot water allowed to mix with the cold, the HOT LIMIT SAFETY STOP (1) reduces risk of accidental scalding. To set the maximum hot water temperature of your faucet, all you need to do is adjust the setting on the HOT LIMIT SAFETY STOP (1).

- Turn CARTRIDGE STEM (2) to the OFF position (coldest setting) before making adjustment to HOT LIMIT STOP (1). Use a flat blade screwdriver to pry free the HOT LIMIT SAFETY STOP (1). Pull forward and rotate counterclockwise one number to limit hot water temperature. Use ARROW (3) on CARTRIDGE (4) and NUMBERS (5) on HOT LIMIT STOP (1) for indication.

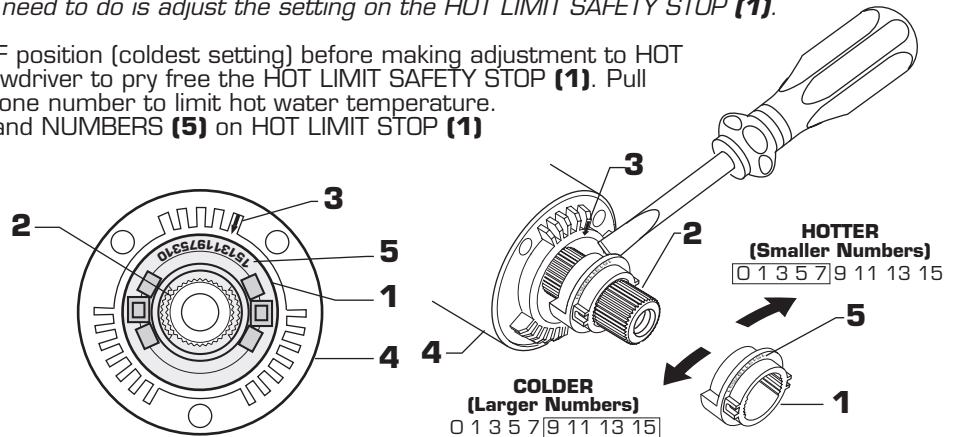

6 BACK TO BACK INSTALLATION (SEE ILLUSTRATION STEP 8 FOR REFERENCE)

- Remove Handle and Trim from Valve. See step 4a for reference.
- Remove PRESSURE BALANCE UNIT (5). Rotate PRESSURE BALANCE UNIT (5) 180° so that the inlets face up and the large outlet port faces down.
- Push PRESSURE BALANCE UNIT (5) in casting make sure inlets line up with holes in bottom of casting. Top flange should butt up against top of casting.
- Reassemble FIXATION RING (4) and CARTRIDGE (1).

7 TEST INSTALLED FAUCET

- Turn VALVE "off".
- With HANDLE in "off" position, turn on water supplies and check all connections for leaks.
- Operate HANDLE and flush water lines thoroughly. Pull DIVERTER and check SHOWER for proper operation.
- Check SPOUT and SHOWER connections for leaks.

8 TO GAIN ACCESS TO VALVE FOR SERVICING

- Remove Handle and Trim from Valve. See step 3 for reference.
- Shut off water supply by either closing off main water supply, or closing off the hot and cold CHECK STOPS on valve, if present.

VALVE LEAKS WHEN SHUT OFF

- Remove CARTRIDGE (1) by removing CARTRIDGE SCREWS (2). Remove three SCREWS (3) from FIXATION RING (4) and pull out PRESSURE BALANCING (5) unit.
- Clean SEALS (9) on base of CARTRIDGE (1). Check base of PRESSURE BALANCING UNIT (5) and clean O-RINGS (6). Remove CAPS (7) and check O-RINGS on inside of CAPS (7). Clean inside sealing surfaces of VALVE BODY (8).
- Re-assemble PRESSURE BALANCING UNIT (5) and CARTRIDGE (1). Tighten all screws. Turn on water supply and see above for installing TRIM and HANDLE.

UNABLE TO MAINTAIN CONSTANT TEMPERATURE

- Remove PRESSURE BALANCE UNIT (5). Remove CAPS (7) and clean valve thoroughly.
- Examine balancing unit and check condition of O-ring on end of piston. Piston should move back and forth. Order Repair Part M952100-0070 if balancing unit is defective.
- Replace CAPS (7) and install PRESSURE BALANCE UNIT (5). Make sure inlets line up with two holes in bottom of casting. Top flange should butt-up against top of casting.

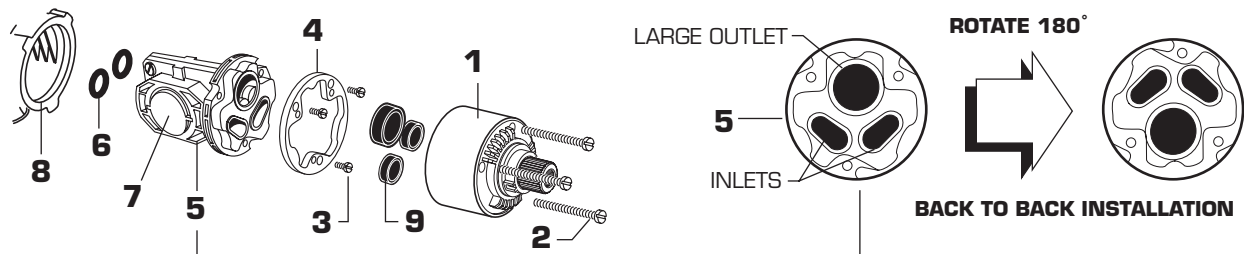

8 HELPFUL HINTS FOR CLEANING AND MAINTENANCE

The solid brass product you have just purchased has been designed to give you years of beauty and service. It is important to bring to your attention proper care and maintenance procedures, which will ensure its lasting beauty.

- First and foremost, it is important (as it is with any fine piece of jewelry or furniture) that the product be wiped clean and dry with a soft damp cloth after every use.
- Second, under no circumstances should an abrasive cleaner or combination cleaner/polish be used on JADO products. The abrasive nature of such products will eventually destroy the finish and void the warranty.
- In the event of stubborn blemishes shown on the finish, we recommend use of Windex window cleaner with a soft cloth, but we do not recommend it be used on an everyday basis.
- It is important to note that it is normal to expect signs of usage over time.

Thank you for selecting JADO for your home.

TO THE PURCHASER OF JADO BRASS PRODUCTS

Attention installer:

Please leave This Pamphlet for The Owner

NOTICE: JADO products conform to industry requirements of water conservation under the ASTM / ANSI A112.18.1-2005 plumbing code. Lavatory, bidet, wet bar and kitchen faucet sets have a maximum flow rate of 2.2GPM. Shower heads, hand showers and body sprays have a maximum flow rate of 2.5GPM.

The state of California has mandated under Proposition #65 that manufactures of products, including faucets which come into contact with potable water, must warn the consumer if the product contains materials listed by the state as a carcinogen or reproductive toxin. Lead, which is contained in all brass faucets in limited amounts appears on the State's list.

Preliminary industry tests have indicated that users of faucets made from brass face no significant danger, however, California Proposition #65 requires that we provide you with the following notice:

Warning: This product contains an element known to the State of California to cause cancer or reproductive harm.

JADO BATHROOM AND HARDWARE MFG. CORP.
6615 West Boston
Chandler, AZ 85226

JADO FAUCET LIFETIME FUNCTION AND FINISH LIMITED WARRANTY

JADO Bathroom & Hardware Manufacturing Corp. provides the following warranties only to the first residential owner of our products.

FINISHES
JADO warrants this product to be free from defects in materials or workmanship for as long as the original consumer purchaser owns their home.

JADO will provide, free of charge, at it's sole option, replacement part(s) or product (or if no longer available, a comparable product) to replace those which have proven defective in materials or workmanship.

Proof of purchase (original sales receipt) from the original consumer purchaser must be made available to JADO for all limited warranty claims. This limited warranty is non transferable. It does not apply in the event of product damage due to the use of other than genuine JADO replacement parts, installation error, abuse, misuse, or improper care and maintenance (whether performed by a plumber, contractor, service provider or member of the purchaser's household). The limited warranty excludes damage due to aggressive air or water conditions, or harsh or abrasive cleaners and/or materials. This limited warranty excludes all industrial, commercial and business usage, whose purchasers are hereby extended a two year limited warranty (with the exception of solenoid valves and other electronic components which carry a one year limited warranty) applying to all other terms of this limited warranty except duration. This limited warranty does not cover labor charges incurred and/or damages sustained in installation, repair or replacement, nor incidental or consequential damages, all of which are expressly disclaimed. This limited warranty is applicable only to JADO faucets manufactured after June 1, 1996 and installed in the United States and/or Canada.

This limited warranty gives the original consumer purchaser of an JADO faucet specific legal rights which may vary from state to state or from province to province. This limited warranty does not cover any liability for consequential or incidental damages, all of which are hereby expressly disclaimed, or the extension beyond the duration of this limited warranty of any implied limited warranties, including those of merchantability or fitness for an intended purpose. In some states or provinces the exclusion or limitation of incidental or consequential damages is not allowed, so those exclusions may not apply to you.

POLISHED BRASS AND CUSTOM FINISH WARRANTY: A 1 YEAR LIMITED FINISH WARRANTY from date of purchase is provided to the first residential owner against defects in materials and workmanship. Due to the ever-changing finish of Patina products, the finish warranty is excluded. Warranty shall not include problems related to the installation of the product.

MECHANICS

MECHANICAL WARRANTY: A LIFETIME LIMITED WARRANTY is provided to the first residential owner on parts to be free from failure related to defects in materials and workmanship but not installation.

CONDITIONS TO WARRANTIES

JADO Bathroom & Hardware Manufacturing Corp. places the following conditions on its finish and mechanical warranties to the first residential owner only. JADO finish and mechanical warranties are limited to products correctly installed and used in a residential environment.

JADO warranties will not assume liability for damage due to abuse, mishandling, incorrect installation, improper maintenance, or deterioration due to normal use.

JADO will not be liable for labor or other costs relating to the sale, installation, or replacement of their products.

In the event of a defect in any JADO product covered by this warranty, the product must be returned to the dealer where originally purchased along with proof of purchase.

JADO's obligation under the warranty shall be limited to the repair or exchange of any product which has been determined by JADO to be defective after appropriate examination.

H965860