

INTRODUCTION

This instruction sheet will provide you with information required to safely own and operate the Little Giant 10E and 10S series pumps. The pump you have purchased is a submersible effluent pump for use in basins or lift stations and suitable for pumping sewage, effluent, wastewater and other non-explosive, non-corrosive liquids. The 10S Series sewage ejector pumps have a 2" spherical solids handling capability. The 10E Series sewage effluent pumps have a 3/4" spherical solids handling capability.

This instruction sheet covers the standard models in this pump series. This form is applicable to other models in this series not listed by catalog number in the replacement parts list section of this pamphlet. If the catalog number of your pump is not listed in the replacement parts section, then caution should be exercised when ordering replacement parts. Always give the catalog number of your pump when ordering replacement parts.

The Little Giant unit you have purchased is of the highest quality workmanship and material. It has been engineered to give you long and trouble-free service.

Little Giant pumps are carefully inspected, tested, and packaged to insure safe operation and delivery. When you receive your pump, examine it carefully to determine that there are no broken or damaged parts that may have occurred during shipment. If damage has occurred, make notation and notify the firm from which you purchased the pump. They will assist you in replacement or repair, if required.

Read instructions carefully before attempting to install, operate or service the Little Giant pump. Know the pump applications, limitations, and potential hazards. Protect yourself and others by observing all safety information. Failure to comply with instructions could result in personal injury and/or property damage. Retain instructions for future reference.

SAFETY GUIDELINES



- Do not use to pump flammable or explosive fluids such as gasoline, fuel oil, kerosene, etc. Do not use in explosive atmospheres. Pump should only be used with liquids compatible with pump component materials.
- Do not handle pump with wet hands or when standing on a wet or damp surface, or in water.
- Do not use power cord for lifting the pump.
- This pump is supplied with a grounding conductor and/or grounding-type attachment plug. To reduce the risk of electric shock, be certain that it is connected to a properly grounded grounding-type receptacle.
- The National Electric Code requires a ground fault circuit interrupter (GFCI) be installed in the branch circuit supplying fountain equipment, pools, etc.
- In any installation where property damage and/or personal injury might result from an inoperative or leaking pump due to power outages, discharge line blockage, or any other reason, a backup system(s) and/or alarm should be used.
- Support pump and piping when assembling and when installed, failure to do so may cause piping to break, pump to fail, motor bearing failures, etc.
- This pump's motor housing is filled with a dielectric oil for motor heat transfer and lifetime lubrication of the bearings. This oil is non-toxic to aquatic life; however, suffocation can occur if oil is left on the water surface. If oil escapes the motor housing, it can be removed from the surface quickly by placing newspapers on the water surface to soak up the oil.
- The pump motor is equipped with an automatic resetting thermal protector and may restart unexpectedly. Protector tripping is an indication of motor overloading as a result of excessively high or low voltage, inadequate wiring, incorrect motor connections or a defective motor or pump.

ELECTRICAL CONNECTIONS



- Check the pump label for proper voltage required. Do not connect to voltage other than that shown.
- If pump is supplied with a 3-prong electrical plug, the third prong is to ground the pump to prevent possible electrical shock hazard. **DO NOT REMOVE** the third prong from the plug. A separate branch circuit is recommended. Do not use an extension cord. Do not cut plug from the cord. If the plug is cut or the cord is shortened, then this action will void the warranty.
- If the cord is equipped with stripped lead wires, such as on 230V models, be sure that the lead wires are connected to a power source correctly. The green/yellow wire is the ground, the other two are live.
- Check local electrical and building codes before installation. The installation must be in accordance with their regulations as well as the most recent National Electrical Code (NEC).
- To conform to the National Electrical Code all pumps must be wired with 14 AWG or larger wire. For runs to 250', 14 AWG wire is sufficient. For longer runs, consult a qualified electrician or the factory.
- Pump should be connected or wired to its own circuit with no other outlets or equipment in the circuit line. Fuses and circuit breaker should be of ample capacity in the electrical circuit.
- The flexible PVC jacketed cord assembly mounted to the pump must not be modified in any way, with the exception of shortening the cord to fit into a control panel. Any splice between the pump and the control panel must be made within a junction box and mounted outside of the basin and comply with the National Electrical Code.

OPERATION

- Pump must be installed in a suitable gas tight basin which is at least 18" in diameter and 24" deep, and vented in accordance with local plumbing codes.
- 10E series features 1-1/2" female NPT discharge. 10S series features 2" female NPT discharge.
- Pump must be placed on a hard level surface. Never place pump directly on clay,

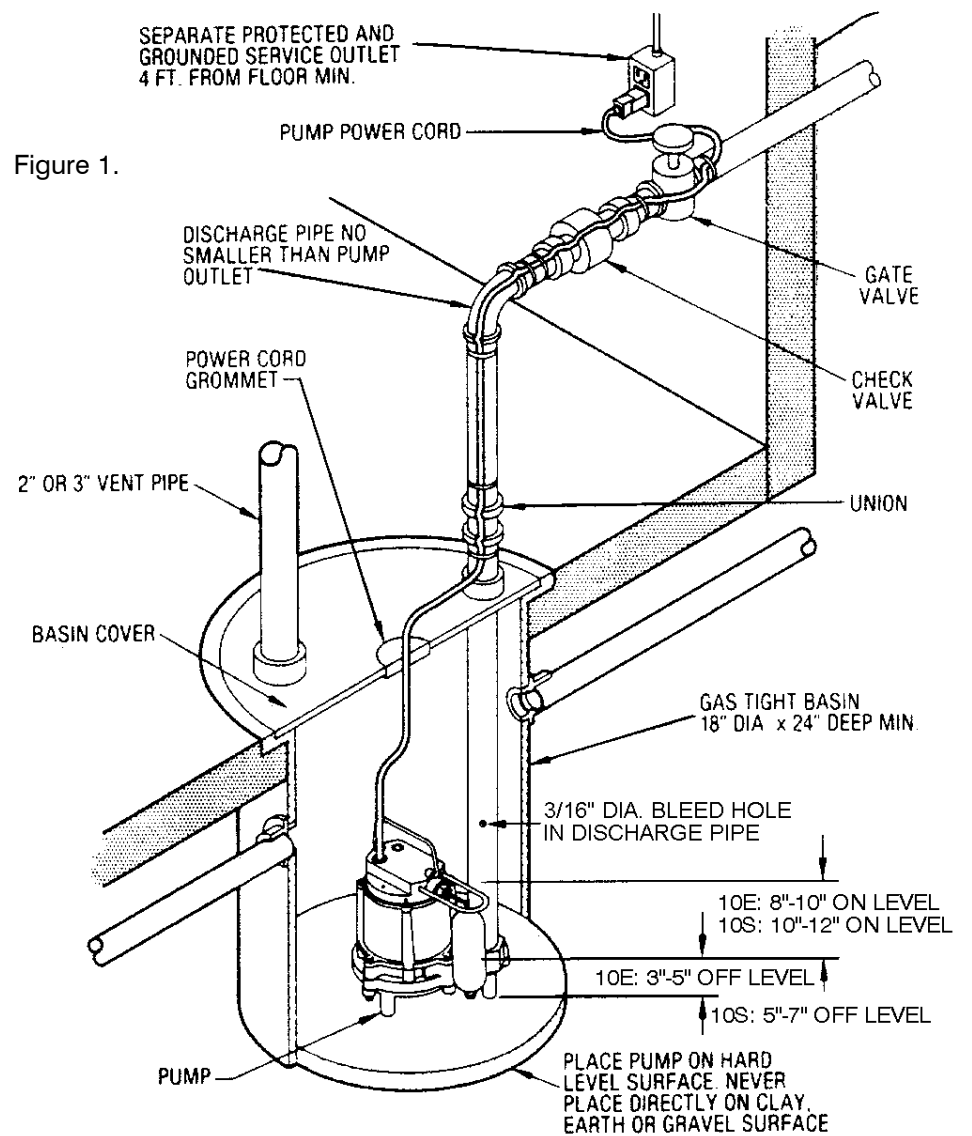

Figure 1.

earth or gravel surfaces.

- A check valve must be used in the discharge line to prevent backflow of liquid into the basin. The check valve should be a free flow valve that will easily pass solids. Drill a 3/16" hole in the discharge pipe approximately 1"-2" above the pump discharge connection and below check valve to prevent air locking the pump.

CAUTION: For best performance of check valves, when handling solids install in a horizontal position or at an angle of no more than 45°. Do not install check valve in a vertical position, as solids may settle in valve and prevent opening on start-up.

- Do not attempt to restrict the intake side of these pumps. Restricting the intake may cause damage to the seal and may starve the pump. If you require reduced flow rates, then place a valve on the discharge side of the pump or if flexible vinyl tubing is used, a clamp can be used on the tubing to restrict the flow.
- Do not let the unit operate dry. It is designed to be cooled by pumping fluid. You may damage the seal and the motor may fail if the pump is allowed to run dry.
- If the unit is going to be idle for a period of time, follow the cleaning instructions outlined in the next section. Do not let the unit freeze in the wintertime. This may cause cracking or distortion that may destroy the unit.

TESTING PUMP OPERATION

- These pumps are equipped with a float operated mechanical switch.
- When these pumps are installed in a basin with a sealed cover, switch operation cannot be observed. The sump cover usually will have a spare hole that is plugged with a rubber plug. This plug can be removed and switch operation can be observed.
- Plug power cord into a grounded receptacle with voltage consistent with pump voltage as indicated on pump nameplate.
- Run water into pump until pump starts.
- Be sure gate valve in discharge line is open.
- Allow pump to operate through several on-off cycles.

SERVICE INSTRUCTIONS

MAKE CERTAIN THAT THE UNIT IS DISCONNECTED FROM THE POWER SOURCE BEFORE ATTEMPTING TO SERVICE OR REMOVE ANY COMPONENT!

- If pump does not operate properly, consult the troubleshooting chart. If trouble cannot be located with the steps shown, consult your pump dealer or take pump to a Little Giant authorized service center.
- Do not remove the three socket head cap screws (item #11). The motor section on your pump is permanently lubricated with dielectric oil and sealed at the factory. Removal of these socket head cap screws by anyone other than an authorized Little Giant service center will break the seal and void the warranty.
- Periodic cleaning of the pump parts will prolong the LIFE and EFFICIENCY of the pump. Refer to Figure 2 for the assembly and disassembly of the pumping head.
- On 10E Series: Remove five screws (item #23) that hold screen base and base plate to volute/plate.
On 10S Series: Remove four hex bolts (item #39) that hold volute to plate. Remove volute.
Do not use strong solvents on impeller.
- Be sure impeller turns freely after cleaning.
- WARNING: DO NOT REMOVE IMPELLER. REMOVAL OF IMPELLER REQUIRES SPECIAL TOOLS AND IS TO BE DONE ONLY BY AN AUTHORIZED SERVICE CENTER. DO NOT REMOVE MOTOR HOUSING COVER. WARRANTY IS VOID IF MOTOR HOUSING COVER, IMPELLER OR SEALS HAVE BEEN REMOVED. ANY REPAIR ON MOTOR MUST BE DONE BY AN AUTHORIZED LITTLE GIANT SERVICE CENTER.**
- Be certain power cord is in good condition and contains no nicks or cuts.

Figure 2.

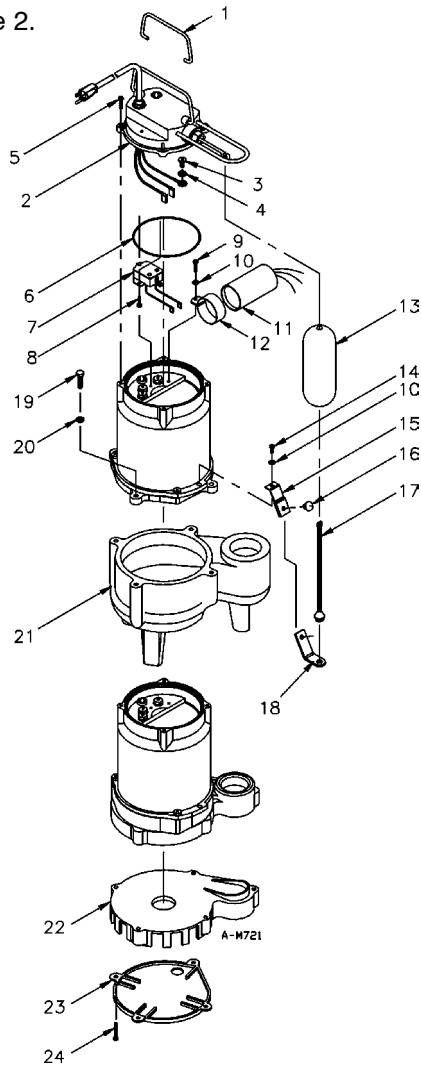

ITEM	PART NO.	DESCRIPTION	QTY	MODEL NO./CATALOG NO.				
				10E-CIA-SFS 511350	10F-CIA-SFS 511355	10S-CIA-SFS 511550	10S-CIA-SFS 511555	10S-CIA-SFS 511565
1	108101	HANDLE	1	•	•	•	•	•
2	110349	COVER ASSEMBLY, 10FT, (115V)	1	•		•		
2	110350	COVER ASSEMBLY, 25FT, (115V)	1		•			
2	110351	COVER ASSEMBLY, 25FT, (230V)	1					•
3	902307	SCREW, #6-32 X 1/4	1	•	•	•	•	•
4	921028	WASHER, LOCK	1	•	•	•	•	•
5	909022	SCREW/WASHER, 10-24 X 5/8	4	•	•	•	•	•
5	106350	SWITCH HOUSING	1	•	•	•	•	•
6	928002	SEAL RING, NITRILE	1	•	•	•	•	•
7	950250	SWITCH	1	•	•	•	•	•
8	902431	SCREW, 8-18 X 1/2	2	•	•	•	•	•
9	902520	SCREW, 10-24 X 3/8	1	•	•	•	•	•
10	921023	WASHER, LOCK	2	•	•	•	•	•
11	950507	CAPACITOR ASSY., 10-SFS	1	•	•	•	•	•
12	110101	BRACKET, CAPACITOR	1	•	•	•	•	•
13	106362	FLOAT	1	•	•	•	•	•
14	902516	SCREW, TAPPING, 10-24 X 1/2	1	•	•	•	•	•
15	110100	RETAINER, FLOAT ROD STRAP	1	•	•	•	•	•
16	929451	PUSH-IN FASTENER	1	•	•	•	•	•
17	106381	ROD, FLOAT	1	•	•	•	•	•
18	106367	STRAP, FLOAT	1	•	•	•	•	•
19	915907	BOLT, HEX	4			•	•	•
20	921103	WASHER, LOCK	4			•	•	•
21	111415	VOLUTE	1			•	•	•
22	109150	BASE, SCREEN	1	•	•			
23	109151	PLATE, BASE	1	•	•			
24	909024	SCREW/WASHER	5	•	•			

TROUBLESHOOTING INFORMATION

PROBLEM	PROBABLE CAUSES	CORRECTIVE ACTIONS
Pump does not turn on.	Pump not plugged in.	Plug in pump.
	Circuit breaker shutoff or fuse removed.	Turn on circuit breaker or replace fuse.
	Accumulation of trash on float.	Clean float.
	Float obstruction.	Check float path and provide clearance.
	Defective switch.	Have pump serviced by authorized service center
	Defective motor.	Have pump serviced by authorized service center.
Pump will not shut off.	Float or float rod obstruction.	Check float and float rod path and provide clearance.
	Pump is air locked.	Shut power off for approximately 1 minute, then restart. Repeat several times to clear air from pump.
	Liquid inflow matches pump capacity.	Larger pump required.
	Defective switch.	Disconnect switch, check with ohmmeter. Open-infinite resistance closed zero.
Pump runs but does not discharge liquid.	Check valve installed backwards.	Check flow indicating arrow on check valve body to ensure it is installed properly.
	Check valve stuck or plugged.	Remove check valve and inspect for proper operation.
	Lift too high for pump.	Check rating table.
	Inlet to impeller plugged.	Pull pump and clean.
	Pump is air locked.	(See corrective action above.)
Pump does not deliver rated capacity.	Lift too high for pump.	Check rated pump performance.
	Low voltage, speed to slow.	Check for proper supply voltage to make certain it corresponds to nameplate voltage.
	Impeller or discharge pipe is clogged.	Pull pump and clean. Check pipe for scale or corrosion.
	Impeller wear due to abrasives.	Replace worn impeller.
Pump cycles continually.	No check valve in long discharge pipe allowing liquid to drain back into basin.	Install a check valve in discharge line.
	Check valve leaking.	Inspect check valve for correct operation.
	Basin too small for inflow.	Install larger basin.

LIMITED WARRANTY

Little Giant #6E, #8E, #9S, #10E, #14EH, and #16EH Series Submersible Effluent Pumps are recommended for use in sumps, basins or lift stations and suitable for pumping basement drainage water, effluent, wastewater and other non-explosive, non-corrosive, non-abrasive liquids not above 140°F with up to 3/4" spherical solids (1/2" on 6E models) handling ability. (Not to be used for sewage water except to pump septic tank effluent.)

Little Giant #9S, #10S, #14S and #16S series Submersible Sewage Ejector Pumps are recommended for use in sumps, basins or lift stations and suitable for pumping sewage, effluent, wastewater and other non-explosive, non-corrosive, non-abrasive liquids not above 140°F with up to 2" spherical solids handling ability. Each of the above noted Little Giant products is guaranteed to be in perfect condition when it leaves our factory. During the time periods and subject to the conditions hereinafter set forth, Little Giant Pump Company, subsidiary of Franklin Electric Company, Inc., will repair or replace to the original user or consumer any portion of your new Little Giant product which proves defective due to materials or workmanship of Little Giant. Contact your nearest Authorized Little Giant dealer for warranty service. At all times Little Giant shall have and possess the sole right and option to determine whether to repair or replace defective equipment, parts, or components, damage due to lightning or conditions beyond the control of Little Giant is NOT covered by this warranty.

WARRANTY PERIOD

PUMPS: 12 months from date of installation or 18 months from date of manufacture, whichever occurs first.

LABOR, ETC. COSTS: Little Giant shall in no event be responsible or liable for the cost of field labor or other charges incurred by any customer in removing and/or affixing any Little Giant product, part or component thereof.

This warranty will not apply:

- to defects or malfunctions resulting from failure to properly install, operate, or maintain the unit in accordance with printed instructions provided
- to failures resulting from abuse, accident or negligence
- to normal maintenance services and the parts used in connection with such service
- to units which are not installed in accordance with applicable local codes, ordinances and good trade practices
- unit is used for purposes other than for what it was designed and manufactured
- if pump exposed to but not limited to the following: sand, gravel, cement, grease, plaster, mud, tar, hydrocarbons, or hydrocarbon derivatives (oil, gasoline, solvents, etc.) or other abrasive or corrosive substances.
- if pump has been used for continuous pumping of suitable liquids above 140°F
- if power cord has been cut or spliced

9. if pump has been dismantled by customer. (Dealer only can dismantle pump for field service.)

RETURN OR REPLACED COMPONENTS: Any item to be replaced under the Warranty must be returned to Little Giant at Oklahoma City, Oklahoma, or such other place as Little Giant may designate, freight prepaid.

PRODUCT IMPROVEMENTS: Little Giant reserves the right to change or improve its products or any portions thereof without being obligated to provide such a change or improvement for units sold and/or shipped to such change or improvement.

DISCLAIMER: Any oral statements about the product made by the seller, the manufacturer, the representatives or any other parties, do not constitute warranties, shall not be relied upon by the user, and are not part of the contract for sale. Seller's and manufacturer's only obligation, and buyer's only remedy, shall be the replacement and/or repair by the manufacturer of the product as described above. Neither seller nor the manufacturer shall be liable for any injury, loss or damage, direct, incidental or consequential (including, but not limited to, incidental or consequential damages for lost profits, lost sales, injury to person or property, or any other incidental or consequential loss), arising out of the use or the inability to use the product, and the user agrees that no other remedy shall be available to it. Before using, the user shall determine the suitability of the product for his intended use, and user assumes all risk and liability whatsoever in connection therewith. The warranty and remedy described in this limited warranty is an EXCLUSIVE warranty and remedy and is IN LIEU OF any other warranty or remedy, expressed or implied, which other warranties and remedies are hereby expressly EXCLUDED, including, but not limited to any implied warranty of MERCHANTABILITY OR FITNESS FOR A PARTICULAR PURPOSE. Some States do not allow the exclusion or limitation of incidental or consequential damages, so the above limitation or exclusion may not apply to you. This warranty gives you specific legal rights, and you may also have other rights which vary from state to state.

In the absence of other suitable proof of the installation date, the effective date of this warranty will be based upon the date of manufacture plus one year. Direct all notices, etc. to: Service Department, Little Giant Pump Company, 3810 N. Tulsa, Oklahoma City, OK 73112.

DETERMINATION OF UNIT DATE OF MANUFACTURE: (9-87) month and year stamped on pump and/or serial number on pump nameplate coded to indicate year of manufacture.

For Parts or Repair, please contact1.888.572.9933
For Technical Assistance, please contact1.888.956.0000

www.LittleGiant.com
customerservice@lgpc.com