

RL2000 Installation (TM, TK, RF)

Before Installation (Prepare lock)

- Set the lock in unlock position.
- Insert the square shaft (A) into the center hub (B), ensuring that the dot on the center hub is pointed up. (Fig 1)
- Insert the position pin into the hole on the center hub to secure the square shaft. Bend the end of position pin around the center hub to secure the pin in place. (Fig 2)

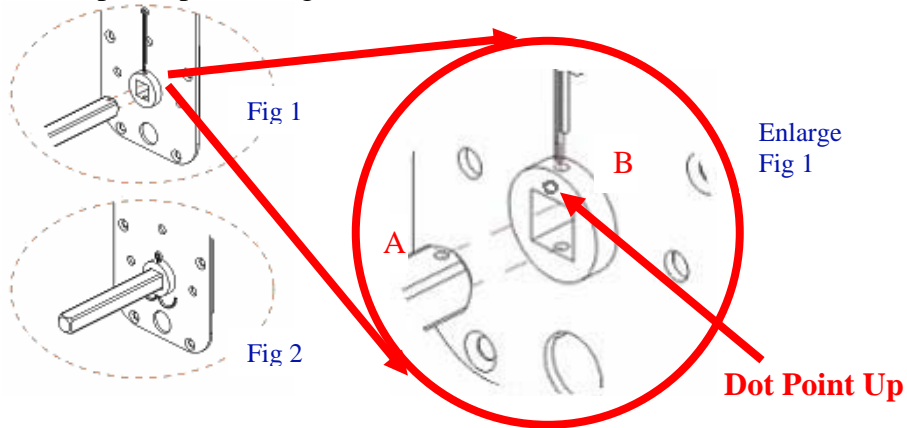

Step 1

Insert the latch into door hole. Secure the latch with two fix screws. (Fig 3)

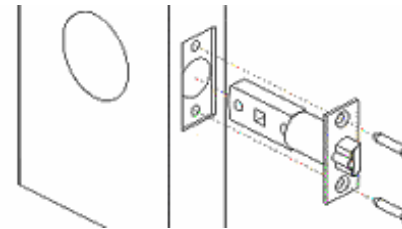

Fig 3

Step 2

Screw in and tighten the two fastener extensions (C) into the front lock fastener posts, located on both side of the center hub. (Fig 4)

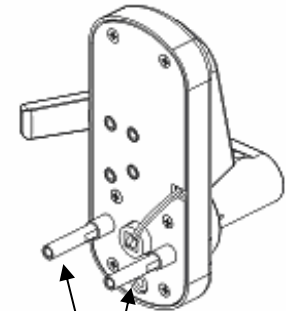

Fig 4

Step 3

Place the front lock housing onto the door, with the rubber gasket (D) between the door and housing (Fig 6). Feed the power plug (E) through the door (Fig 5).

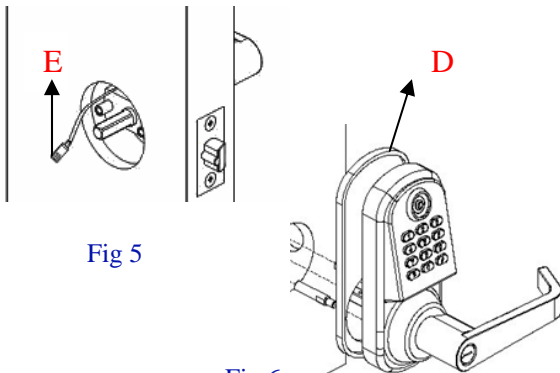

Fig 5

Fig 6

Step 4

Attach the battery plate onto the door, with the rubber gasket between the door and battery plate. Make sure the power plug go through the hole on the plate. Secure the battery plate with 2 screws fasten to front lock fastener post. (Fig 7)

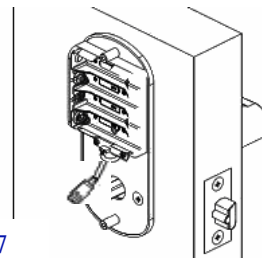

Fig 7

Step 5

Install batteries, and secure the back lock housing onto the battery plate. Fasten with 2 screws. (Fig 8)

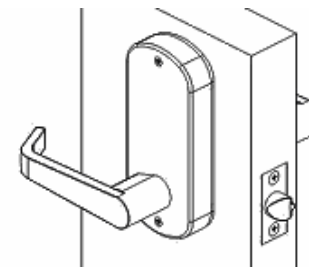

Fig 8

Step 6

Install the dust boot with strike plate onto it.

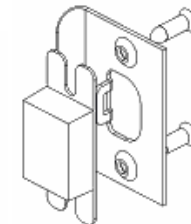
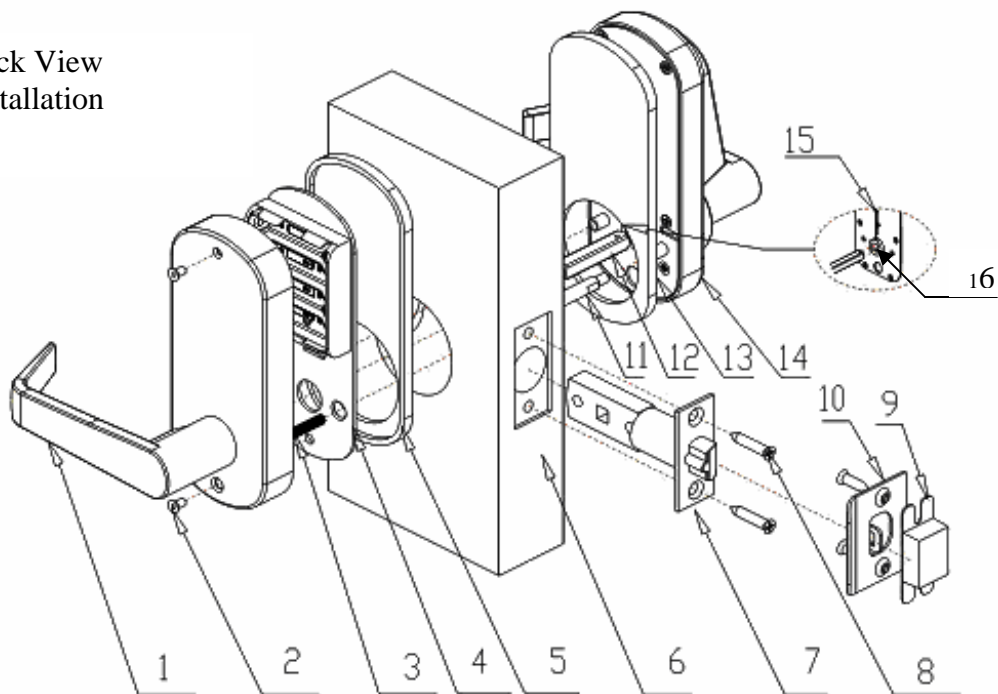

Fig 9

Back View
Installation



Major Lock Parts

1. Back Handle
2. Back Cover Screws
3. Battery Plate Screws
4. Battery Plate
5. Back Rubber Gasket
6. Door
7. Latch
8. Latch Fix Screws
9. Dust Boot
10. Strike Plate
11. Front Lock Fastener Post
12. Square Shaft
13. Front Rubber Gasket
14. Front Lock
15. Position Pin
16. Center Hub

Accessory Parts List

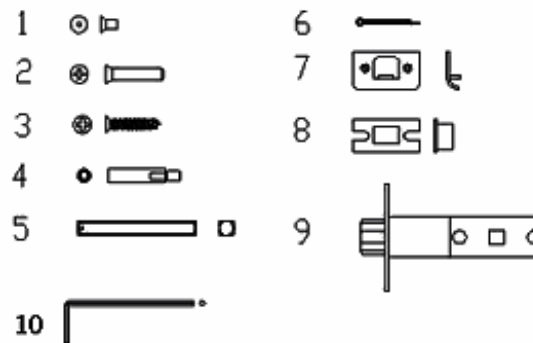

1. Back Cover Screw (2)
2. Battery Plate Screw (2)
3. Latch Screw (2)
4. Fastener Extension (2)
5. Square Shaft (1)
6. Position Pin (1)
7. Door Strike (1)
8. Dust Boot (1)
9. Latch (1)
10. Special Screw Driver (Optional) (1)

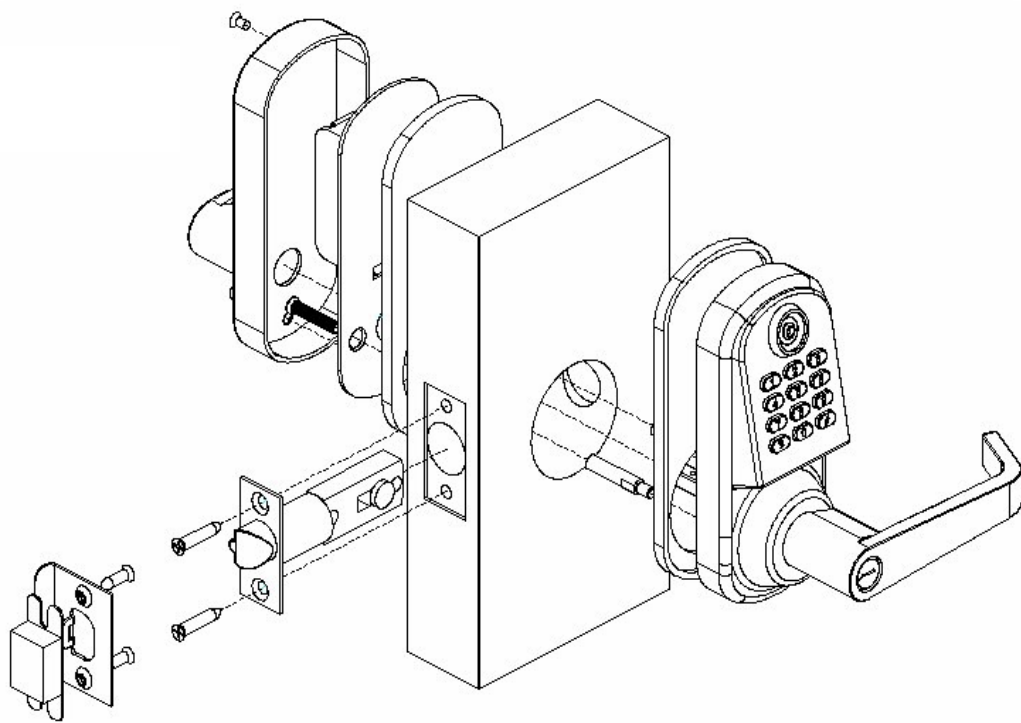

Door Cutting

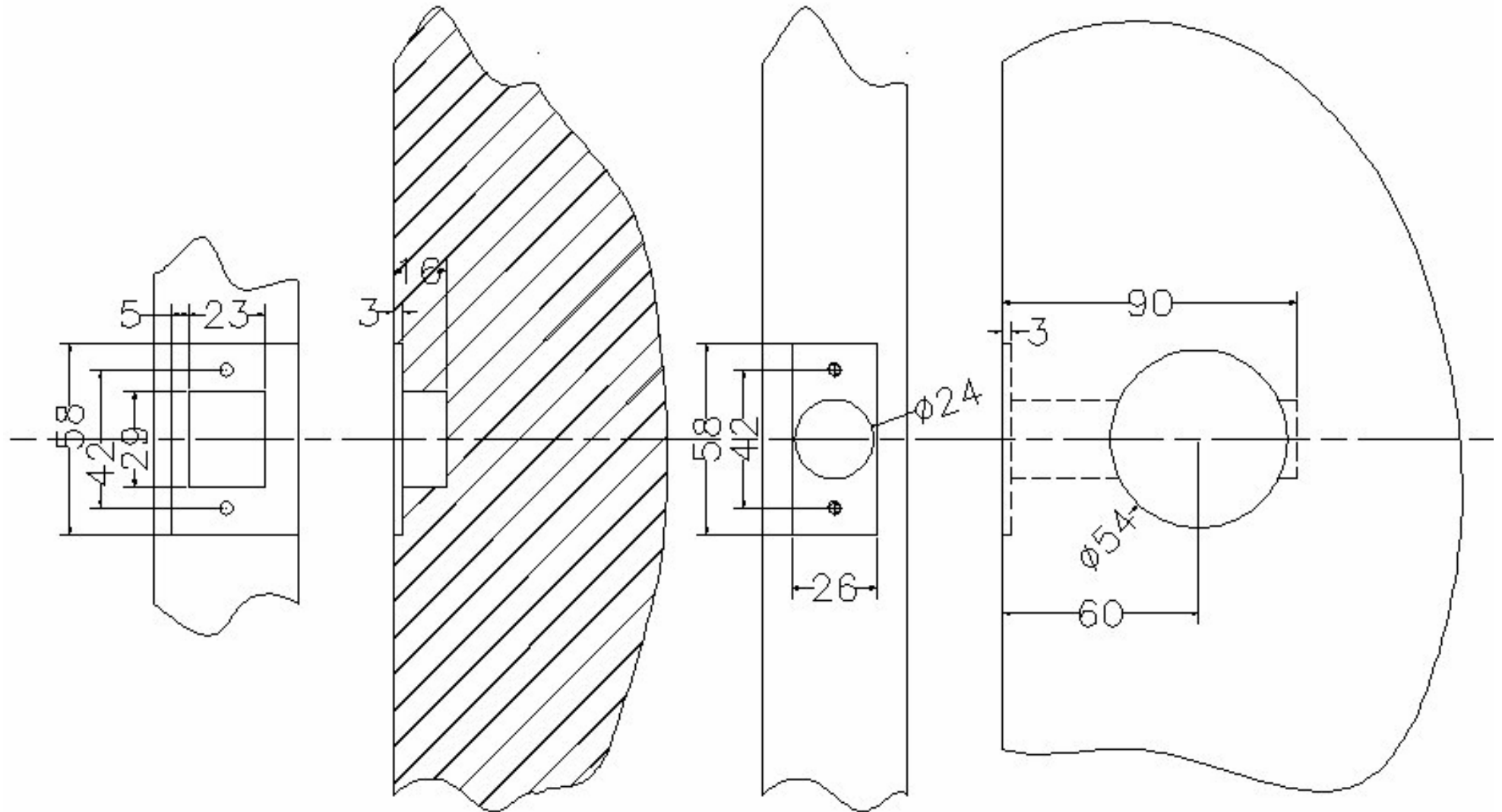

Back Lock Size

RL 2000 Lock Size

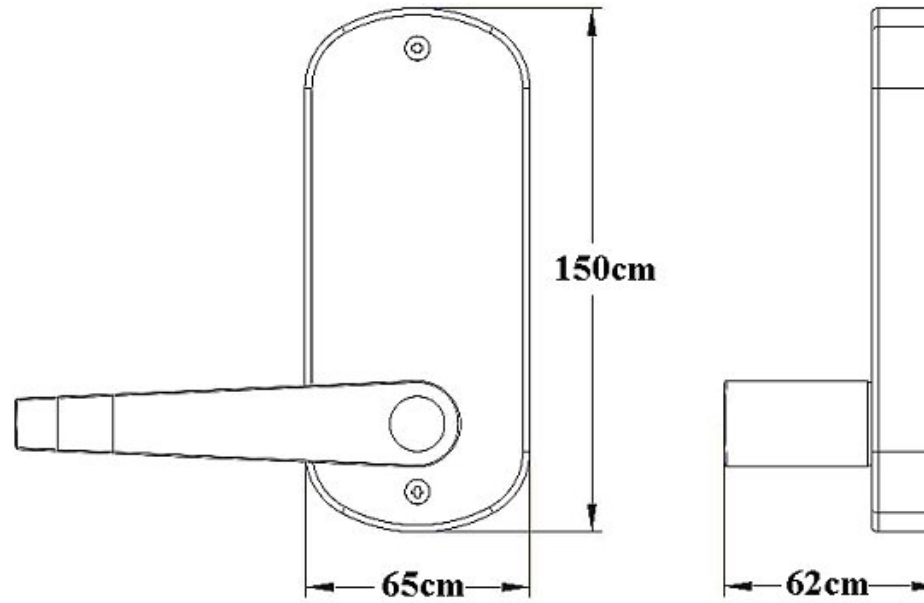

Front Lock Size

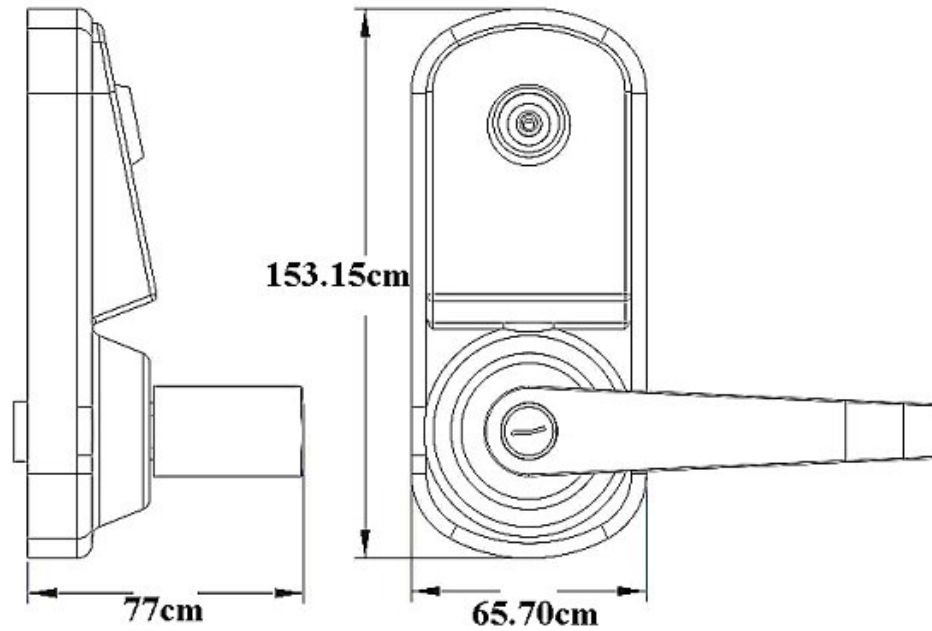

How to Change Handle

Front Lock View

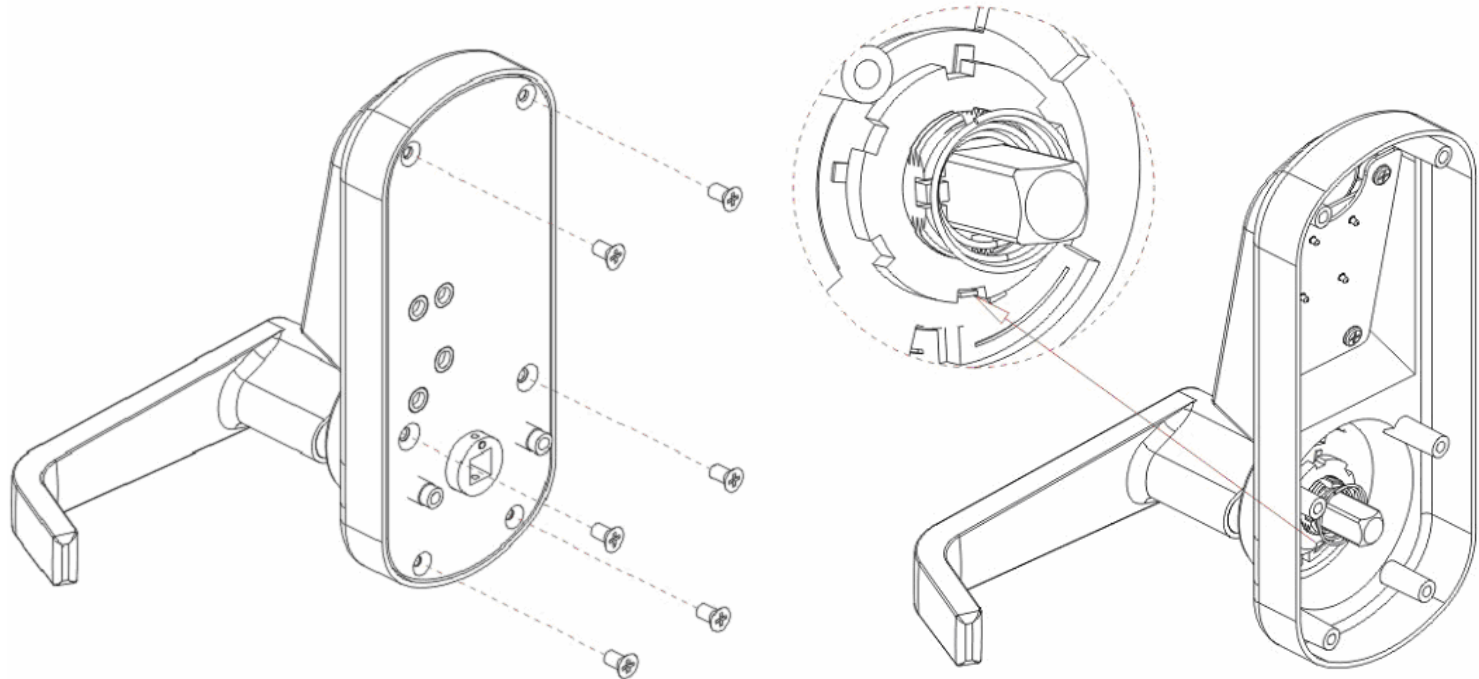

Cylinder Removal or Change Front Lock Handle

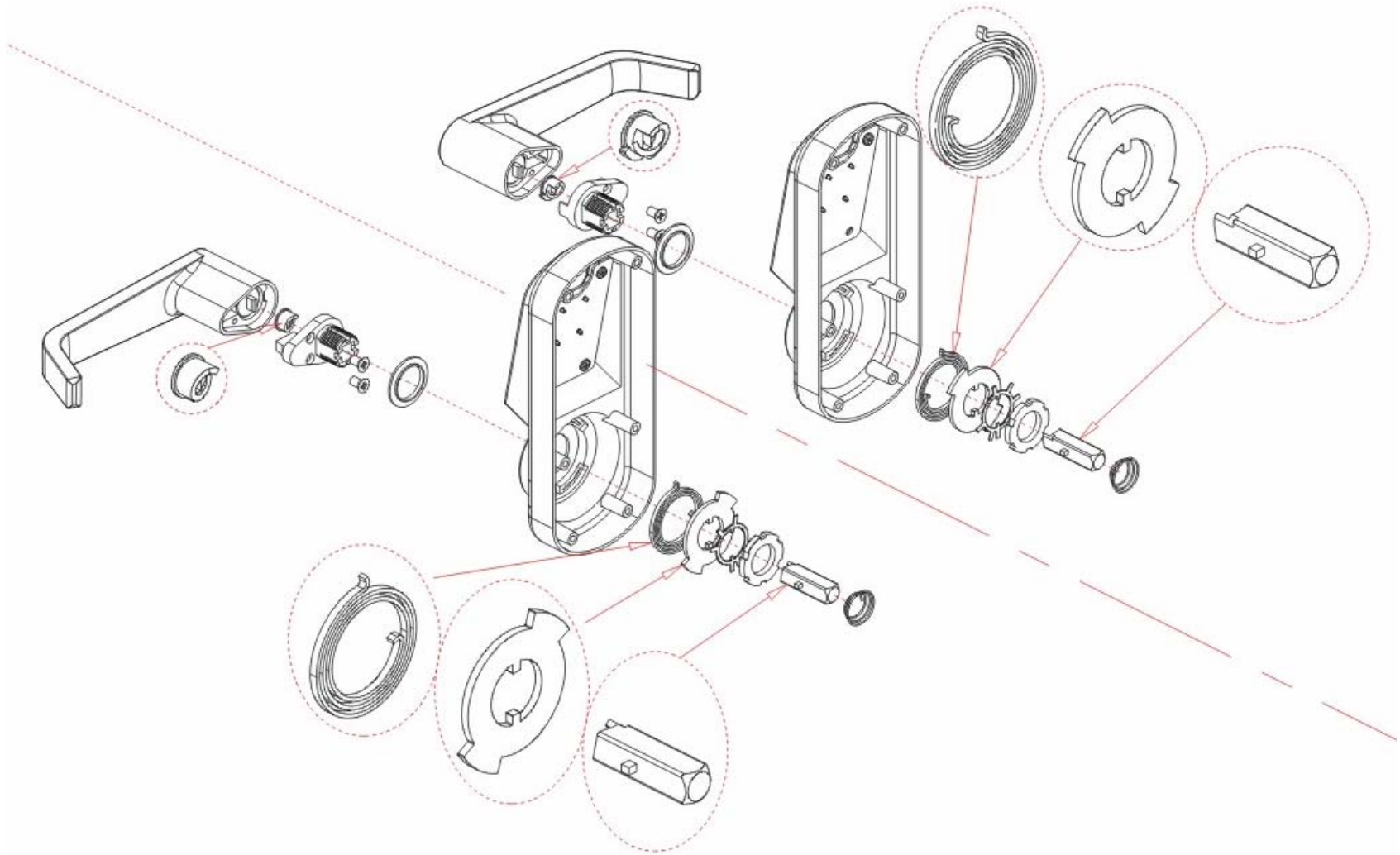

Change Back Handle

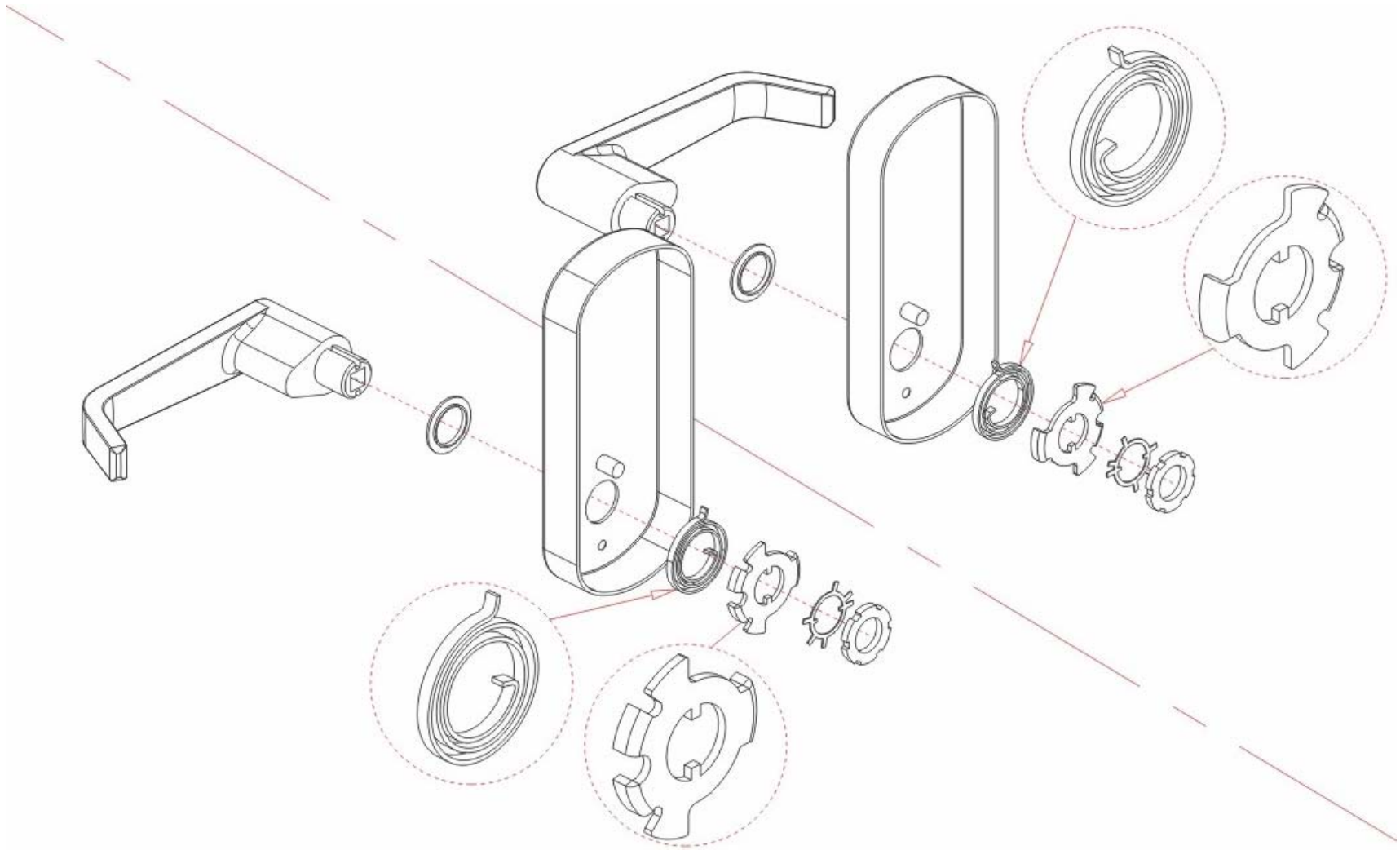

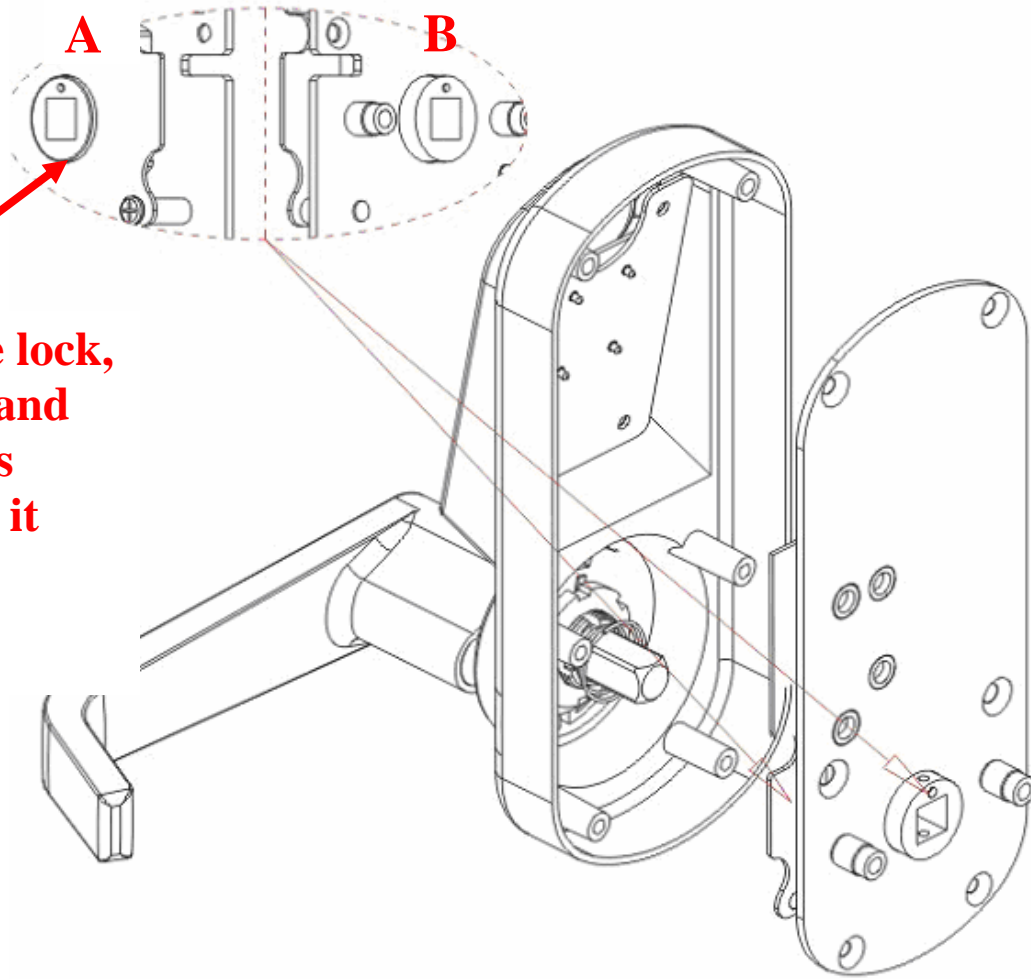

**When assembly the lock,
make sure Part A, and
Part B, the two dots
point up. Fail to do it
will cause lock not
working properly.**