

# INSTALLATION INSTRUCTION FOR FIXTURE 823

**WARNING! SHUT POWER OFF AT FUSE OR CIRCUIT BREAKER.**  
**AVERTISSEMENT! COUPER LE COURANT AU NIVEAU DES FUSIBLES OU DU DISJONCTEUR.**

## MOUNTING THE FIXTURE (Fig. 1)

1. Shut off the power supply at the fuse box or circuit breaker. If necessary, remove the old fixture and all mounting hardware from the outlet box.
2. Carefully unpack your new fixture and lay out all the parts in a clear area. Take care not to lose any parts necessary for installation.
3. Attach the cross bar (B) to the outlet box using the outlet box screws (A) (Size: 8-32 \* 1" L). The side of the cross bar marked "GND" must face out.
4. Follow the wiring instructions carefully (Fig.2).
5. Thread the mounting screws (C) 1/4" into the cross bar (B)
6. Attach the fixture pan (D) to the cross bar (B) by protruding the mounting screw (C) (Size: 8-32 \* 2" L.) through the keyholes in the pan (D), then rotate the pan (D) until the mounting screw (C) (Size: 8-32 \* 2" L.) are seated in the slots of the keyholes then tighten the screws with a screwdriver.
7. Install the bulb(s) in accordance with fixture's specifications. **(DO NOT EXCEED THE MAXIMUM WATTAGE RATING!)** (NE PAS DEPASSER LA PUISSANCE NOMINALE MAXIMALE!).
8. Place the glass shade (E) over the ring (F) and secure the ring (F) onto the pan (D) using the finials (G).

## Wiring (Fig.2)

1. Connect the electrical wires as shown in figure 2, making sure that all wire connectors are secured. If your outlet box has a ground wire (green or bare copper), connect the fixture's ground wire from the cross bar to it. Otherwise, connect the fixture's ground wire directly to the mounting plate using the green screw provided. After, the wires are connected, tuck them carefully into the outlet box.

**Fig.2**

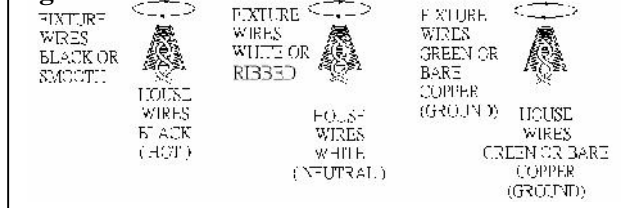

Your installation is now complete. Return power to the outlet box and test the fixture.

**Fig.1**

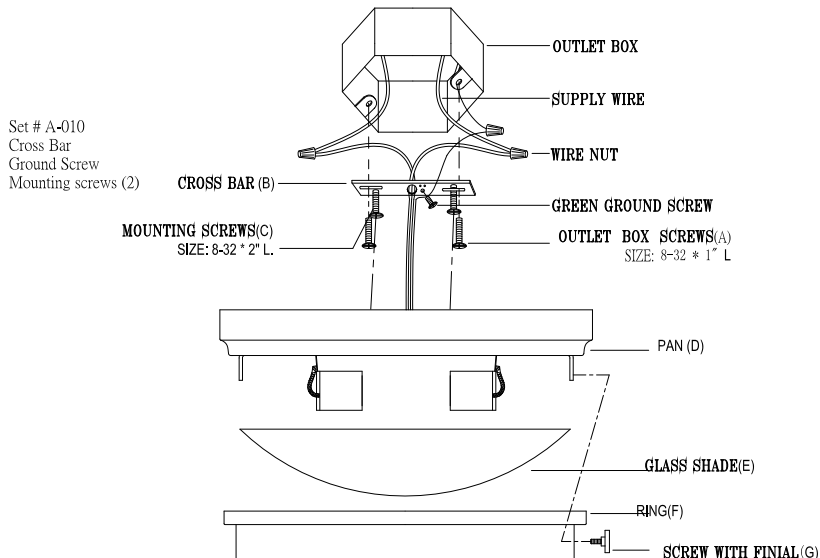

MIN 90 °C SUPPLY CONDUCTORS  
 LES FILS D' ALIMENTATION 90 °C MIN



american  
 lighting  
 association