

## SINK DESCRIPTION

- Manufactured of 22 gauge, type 301 nickel-bearing stainless steel
- Two bowls are 14" x 16" x 6-1/2"
- The sink ledge has three fixture mounting holes, 1-1/2" in diameter and 4" on center
- Has two 3-1/2" diameter recessed drain openings
- Is fully undercoated with a sound and temperature insulating material
- The exposed surfaces are polished to a lustrous satin tone finish
- Includes all necessary mounting hardware

## CUT OUT DIMENSIONS

- Cut out dimensions are 32-3/8" x 21-3/8", with a 1-1/2" corner radius. A tolerance of plus or minus 1/16" is acceptable

## STANDARDS

- Third party certified by IAPMO to meet ASME A112.19.3 and all applicable specifications referenced therein. Also meets applicable requirements of ANSI A117.1

## WARRANTY

- Warranted for five years against material or manufacturing defects

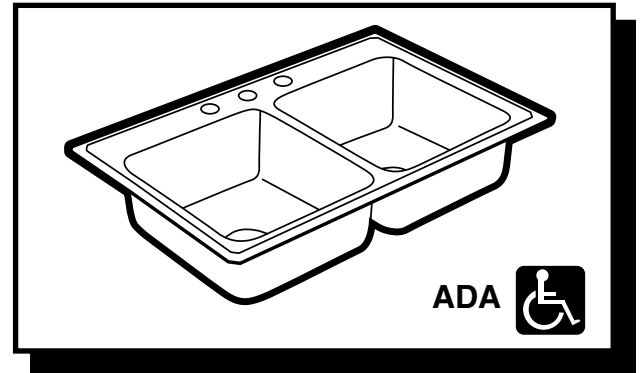

**Excalibur®**  
**Double Bowl Kitchen Sink**  
**Model: 22826**  
**(EDE-3322-3)**

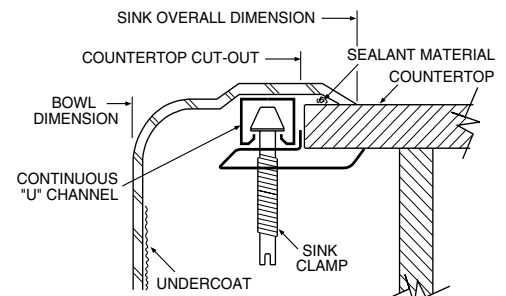

**Installation Detail**

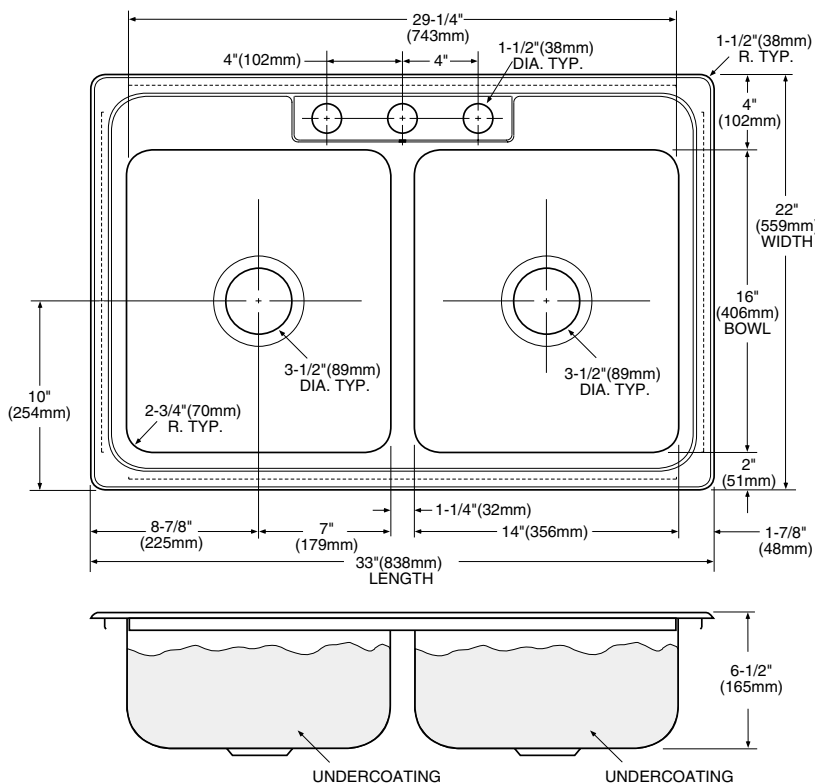

## CRITICAL DIMENSIONS

(DO NOT SCALE)