

PRODUCT DESCRIPTION

- Brass construction w/chrome plated finish
- 1" IPS supply
- 1-1/2" top spud
- 6" cable tube
- 18 gauge x 24" (+) (-) wire leads
- Field adjustable for right or left hand installation
- Optional power adapters
- Single AC transformer (12v) #104406
- Multi-unit AC transformer (power up to 8 units) #104401

OPERATION

- Adjustable sensor eyes
- Low consumption AC powered (12 Volt transformer required)
- Self-diagnostic electronics
- Piston flushing mechanism
- Self cleaning filter system

FLOW

- Operating pressures 10 to 125 psi
- 1.28 gpf (4.8 lpf)
- 24 hour sentinel flush
- Manual override button

VALVE

- 1" IPS angle stop (vandal resistant)
- Adjustable installation (left or right connection)

STANDARDS

- Third party certified by IAPMO and CSA to meet ASME A112.19.2M, ASSE 1037 and all applicable requirements referenced therein

- **ADA** 

WARRANTY

- Warranted for 5 years against material or manufacture defects.

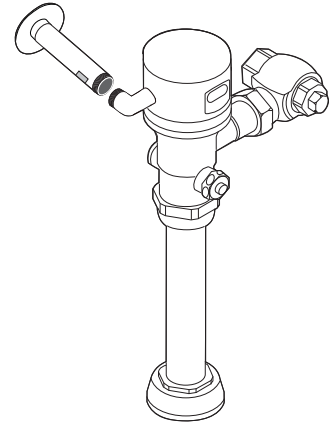

**1-1/2" AC Powered Exposed Style
Closet Flush Valve**

Model: 8311AC12

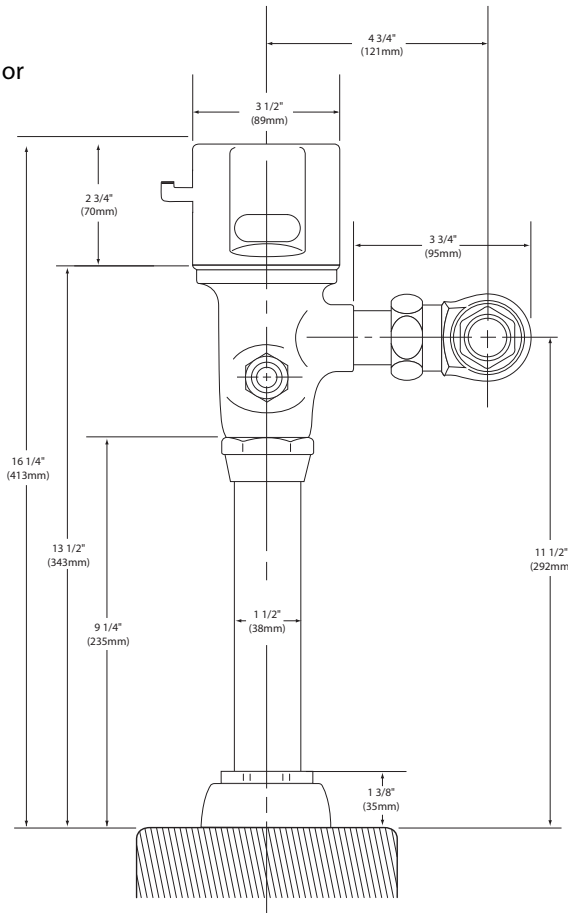

CRITICAL DIMENSIONS

(DO NOT SCALE)