

**STYLELINE
 840P34CH
 MEDICINE CABINET**

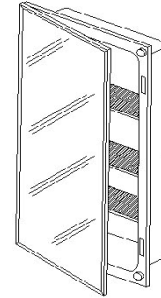

FEATURES

- Recessed installation with recommended wall opening of 14" x 34" x 3-1/2"
- Easy to clean, one piece, steel construction.
- Formed and welded 26 gauge steel body with white powder coat paint finish
- Door back is 26 gauge steel with white powder coat paint finish
- 2MM thick glass mirror on door exterior with standard bright stainless steel trim frame with tab closure
- 32" piano hinge is welded to the door and mechanically attached to the cabinet body
- Two magnetic door catches in the cabinet body align to two stainless steel striker plates on the door back
- Model 840P34CH has three adjustable steel shelves painted white. Multiple shelf positions are available through a series of punched lances in each side of the cabinet body
- Reversible for left-hand or right-hand door opening
- Includes mounting screws

SPECIFICATIONS

Finishes:
 Housing: PT01-Basic White
 Mirror: Flat Mirror
 Frame: SS8-Polish Stainless Steel Trim

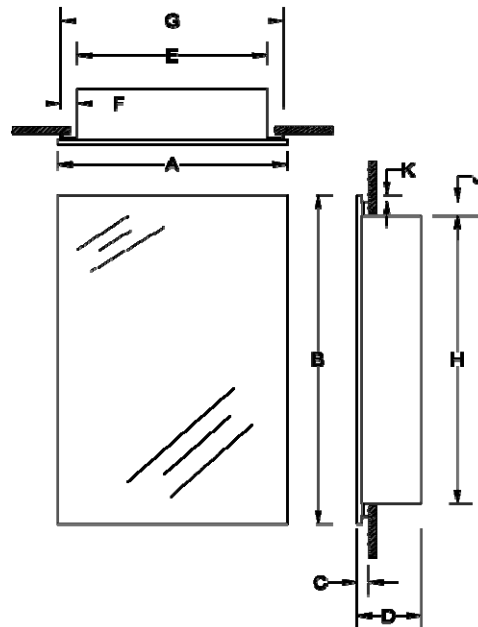

Model Number	DIMENSIONS IN INCHES*									
	A	B	C	D	E	F	G	H	J	K
840P34CH	16-1/8	36-3/16	1-1/16	4-1/2	13-1/2	1	15-1/2	33-9/16	1	3/8

REFERENCE	QTY.	REMARKS	Project
			Location
			Architect
			Engineer
			Contractor
			Submitted by
			Date

* All models and material specifications are subject to change or withdrawal without notice.