



Compact Fluorescent

Fairview
Energy Star

Outdoor

Type _____
 -09EB -31EB
 P5496

Catalog No.	Finish		Lamping	Dimensions (Inches)			
	Brushed Nickel	Black		A	B	C	D
P5496	-09EB	-31EB	1 26w CFL spiral or triple tube (not included)	10-1/2	14-1/2	11-1/4	10

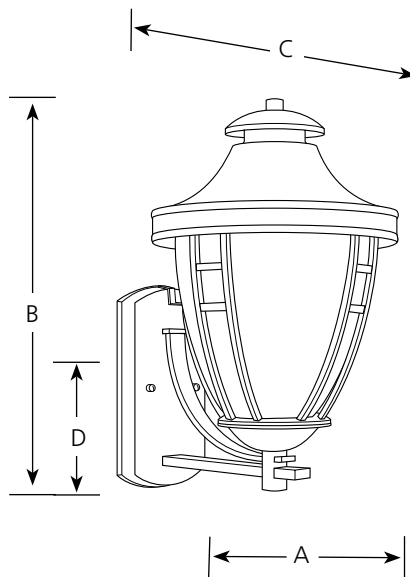

Specifications:

General

- Acorn shape
- Etched glass enclosure
- Tapered round top, and twin bar trim
- Brushed nickel unit is solid brass, and black unit is aluminum construction
- Plated brushed nickel (-09) or black painted (-31) finish
- Energy Star certified

Electrical

- A 4 pin GX24q-3 socket is installed
- 120v NPF electronic ballast
- Unit will start down to 0 degrees F
- Integral photocell turns unit off during daytime
- Pre-wired

Labeling

- UL-CUL wet location listed

Mounting

- Wall mount
- Canopy covers a standard recessed 4" octagonal outlet box
- Mounting strap for outlet box included.



Progress Lighting
 701 Millennium Blvd.
 Greenville, South Carolina
 29607

www.progresslighting.com

Rev. 10/09