

Catalog No.	Finish		Lamping	Dimensions (Inches)		
	Brushed Nickel	Antique Bronze		A	B	C
P5037	-09	-20	3 (m) 100w	22	7-1/4	73-1/4

Type	-09	-20
P5037	<input type="checkbox"/>	<input type="checkbox"/>

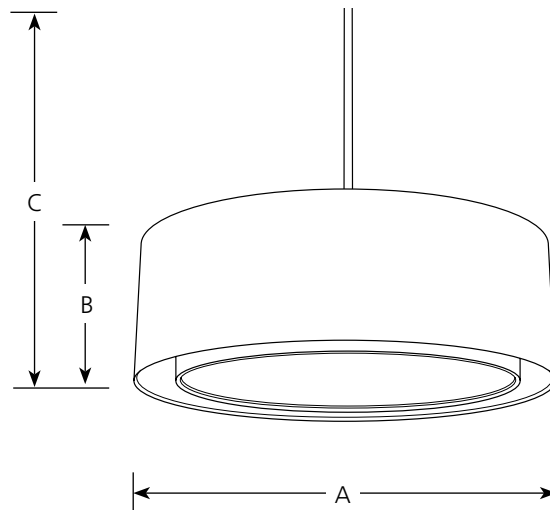

**Specifications:**

General

- White mylar exterior shade with white linen interior shade and white acrylic diffuser
- Plated Brushed Nickel (-09) finish
- Painted Antique Bronze (-20) finish
- Steel construction
- 6 links of 9 gauge chain supplied.
- One 6", four 12" lengths of stem included
- Companion Pendant, Sconce, fixtures are available

Electrical

- Medium base phenolic sockets
- 10 feet of wire supplied
- Pre-wired
- 120V

Labeling

- UL-CUL Dry location listed

Mounting

- Ceiling stem mounted with 6 links of chain mount
- Canopy covers a standard 4" hexagonal recessed outlet box
- Mounting strap for outlet box included