



Incandescent

Motion Sensor  
Energy Star

Outdoor

Type \_\_\_\_\_  
-09 -31 -33  
P5662

Catalog No.	Finish			Lamping	Dimensions (Inches)			
	Brushed Nickel	Black	Cobble-stone		A	B	C	D
P5662	-09	-31	-33	1 (m) 100w	5-1/2	13	6-1/2	6

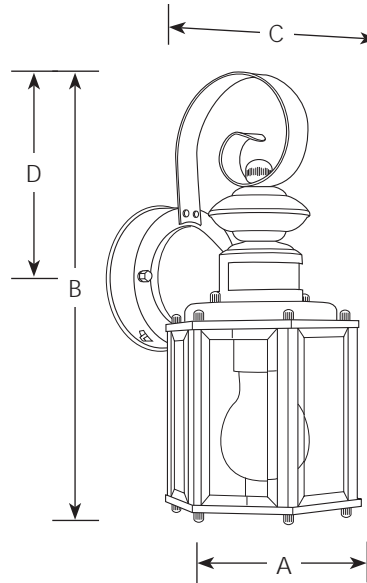

**Specifications:**

General

- Beveled clear glass panels
- Scroll decorative element
- Plated brushed nickel (-09) finish
- Painted black (-31) or cobblestone (-33) finish
- Energy star certified
- Brass construction

Electrical

- Ceramic medium based sockets
- Motion sensor can be set to leave unit on for 5 to 15 minutes after motion ceases
- Integral photocell turns unit off during daytime
- Pre-wired

Mounting

- Wall mounted outdoor
- Covers standard recessed octagonal outlet box
- Mounting strap for outlet box included

Labeling

- UL-CUL "Wet Location" listed



Progress Lighting  
701 Millennium Blvd.  
Greenville, South Carolina  
29607

www.progresslighting.com