



Compact Fluorescent

Roman Coach

Outdoor

Catalog No.	Finish			Lamping	Dimensions (Inches)			
	Brushed Nickel	Antique Bronze	Textured Black		A	B	C	D
P5770	-09	-20	-31	1-26w GU-24	7	15-3/8	7-1/4	6-7/8

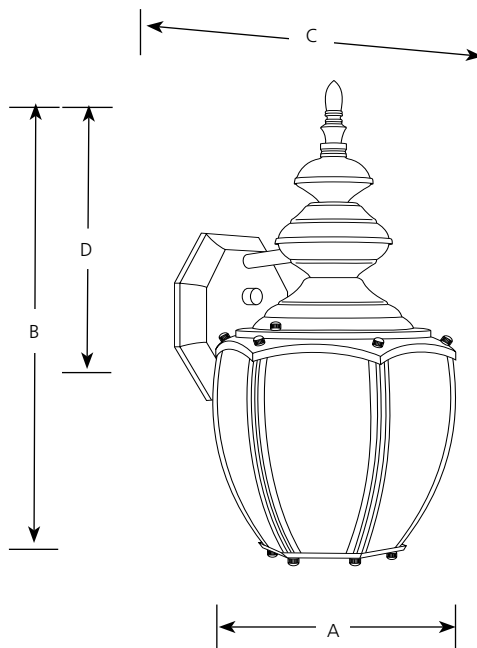

Specifications:

General

- Etched seeded glass curved panels
- Acorn style
- Aluminum construction
- Plated Brushed Nickel (-09) finish
- Painted Antique Bronze (-20), Textured Black (-31) finishes
- Lamp replacement through bottom opening
- Companion Chain hung lantern, Close-to-ceiling, Post top lantern, Wall lantern, fixtures are available

Mounting

- Wall mount
- Back plate covers a standard 4" hexagonal recessed outlet box
- Mounting strap for outlet box included

Electrical

- GU24 base
- Pre-wired

Labeling

- cCSAus Wet location listed

Progress Lighting
701 Millennium Blvd.
Greenville, South Carolina
29607

www.progresslighting.com

Rev. 08/13