



Compact Fluorescent

Ashmore
Energy Star compliant

Outdoor

Catalog No.	Finish		Lamping	Dimensions (Inches)			
	Antique Bronze	Black		A	B	C	D
P5874	-20WB	-31WB	1 GU-24 26w (included)	6-3/8	14-17/8	9-1/2	4-1/2
P5875	-20WB	-31WB	1 GU-24 26w (included)	8-3/8	16-5/8	10-1/2	4-1/2

Type	-20WB	-31WB
P5874	<input type="checkbox"/>	<input type="checkbox"/>
P5875	<input type="checkbox"/>	<input type="checkbox"/>

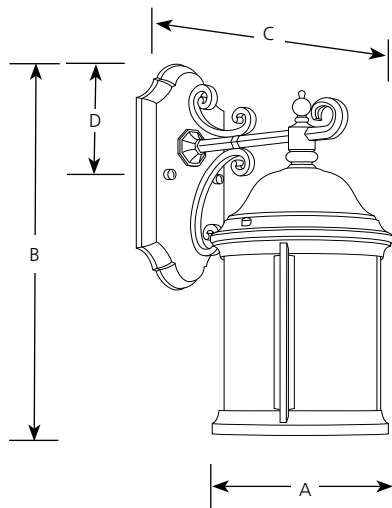

P5874

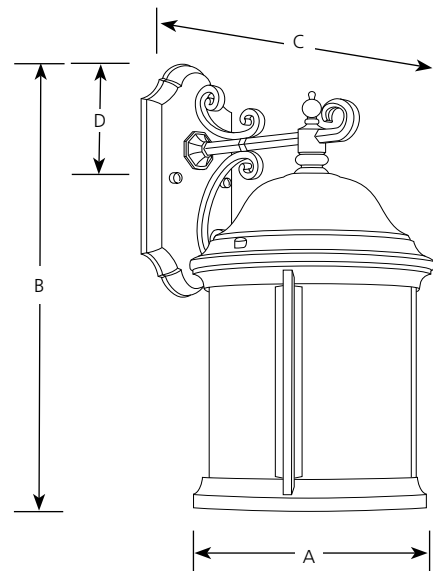

P5875

Specifications:

General

- Etched, water seeded glass curved panels
- Painted Antique Bronze (-20WB), Black (-31WB) finishes
- Each glass panel replaceable
- Cast aluminum construction
- Solid brass interior components
- Scrolled support arms
- Cast wall plate
- One 26w GU-24 lamp (included)
- Energy Star Certified
- Companion Ceiling Fans, Chain hung lantern, Close-to-ceiling, Landscape, Post top lantern, Wall lantern, fixtures are available

Mounting

- Wall mount
- Back plate covers a standard 4" hexagonal recessed outlet box
- Mounting strap for outlet box included

Electrical

- GU24 base sockets
- Pre-wired

Labeling

- cCSAus Wet location listed



Progress Lighting
701 Millennium Blvd.
Greenville, South Carolina
29607

www.progresslighting.com