

Light Duty Commercial Gas Water Heater

USE & CARE MANUAL

WITH INSTALLATION INSTRUCTIONS FOR THE CONTRACTOR

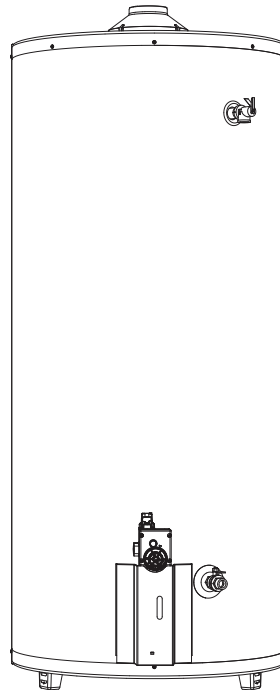

Recognize this symbol as an Indication of Important Safety Information!



Do Not Destroy this Manual. Please read carefully and keep in a safe place for Future Reference.



NOTICE: This water heater is designed for use in a commercial application and the installation and maintenance of it should be performed by qualified, licensed service personnel. If the foregoing assumption is not appropriate, then we recommend that you obtain and retain our Residential Use & Care Manual.



CALIFORNIA PROPOSITION 65 WARNING: This product contains chemicals known to the State of California to cause cancer, birth defects or other reproductive harm.



WARNING: If the information in these instructions are not followed exactly, a fire or explosion may result causing property damage, personal injury or death.

⚠ FOR YOUR SAFETY!

— Do not store or use gasoline or other flammable vapors or liquids or other combustible materials in the vicinity of this or any other appliance. To do so may result in an explosion or fire.

— WHAT TO DO IF YOU SMELL GAS

- Do not try to light any appliance.
- Do not touch any electrical switch; do not use any phone in your building.

- Immediately call your gas supplier from a neighbor's phone. Follow the gas supplier's instructions.
 - If you cannot reach your gas supplier, call the fire department.
 - Do not return to your building until authorized by the gas supplier or fire department.
- Improper installation, adjustment, alteration, service or maintenance can cause injury, property damage or death. Refer to this manual. Installation and service must be performed by a qualified installer, service agency or the gas supplier.

⚠ General Safety Precautions

Be sure to read and understand the entire Use & Care Manual before attempting to install or operate this water heater. Pay particular attention to the following General Safety Precautions. Failure to follow these warnings could result in a fire or explosion, causing property damage, bodily injury or death. Should you have any problems understanding the instructions in this manual, STOP, and get help from a qualified installer or service technician or the gas supplier.

⚠ WARNING

Gasoline, as well as other flammable materials and liquids (adhesives, solvents, etc.), and the vapors they produce, are extremely dangerous. DO NOT handle, use or store gasoline or other flammable or combustible materials anywhere near or in the vicinity of a water heater. Be sure to read and follow the warning label pictured below and other labels on the water heater, as well as the warnings printed in this manual. Failure to do so can result in property damage, bodily injury, or death.

⚠ DANGER

Failure to install the draft hood and properly vent the water heater to the outdoors as outlined in the Venting Section of this manual can result in unsafe operation of the water heater. To avoid the risk of fire, explosion, or asphyxiation from carbon monoxide, never operate this water heater unless it is properly vented and has an adequate air supply for proper operation. Be sure to inspect the vent system for proper installation at initial start-up; and at least annually thereafter. Refer to Maintenance section of this manual for more information regarding vent system inspections.

⚠ DANGER

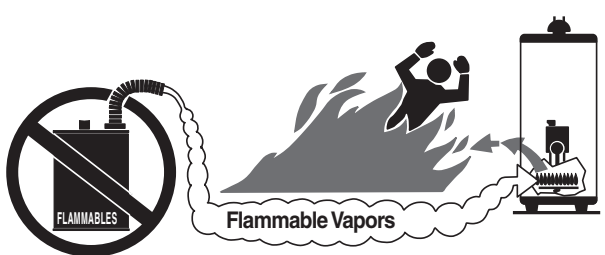

<p>⚠ Vapors from flammable liquids will explode and catch fire causing death or severe burns</p> <p>Do not use or store flammable products such as gasoline, solvents or adhesives in the same room or area near the water heater.</p> <p>Keep flammable products:</p> <ol style="list-style-type: none">1. far away from heater,2. in approved containers,3. tightly closed and4. out of children's reach.	<p>Water heater has a main burner and pilot flame. The pilot flame:</p> <ol style="list-style-type: none">1. is on all the time and2. will ignite flammable vapors. <p>Vapors:</p> <ol style="list-style-type: none">1. cannot be seen,2. are heavier than air,3. go a long way on the floor and4. can be carried from other rooms to the pilot flame by air currents.
---	--

<p>Installation: Do not install water heater where flammable products will be stored or used unless the main burner and pilot flames</p>	<p>are at least 18" above the floor. This will reduce, but not eliminate, the risk of vapors being ignited by the main burner or pilot flame.</p>
---	---

Read and follow water heater warnings and instructions. If owners manual is missing, contact the retailer or manufacturer.

⚠ DANGER

LIQUEFIED PETROLEUM MODELS — Propane, or LP gas, must be used with great caution.

- It is heavier than air and will collect first in lower areas making it hard to detect at nose level.
- Make sure to look and smell for LP leaks before attempting to light appliance. Use a soapy solution to check all gas fittings and connections. Bubbling at a connection indicates a leak that must be corrected. When smelling to detect an LP leak, be sure to sniff near the floor too.
- Gas detectors are recommended in LP applications and their installation should be in accordance with the manufacturer's recommendations and/or local laws, rules, regulations or customs.
- It is recommended that more than one method be used to detect leaks in LP applications.

IF LP GAS IS PRESENT OR SUSPECTED:

- **DO NOT** attempt to find the cause yourself;
- **DO NOT** try to light any appliance;
- **DO NOT** touch any electrical switch;
- **DO NOT** use any phone in your building.
- Leave the building immediately and make sure that everyone else leaves also.
- Leave the doors open for ventilation and contact the gas supplier, a qualified service agency or the fire department.
- Keep the area clear until the service call has been made, the leak is corrected, and a qualified agency has determined the area to be safe.

⚠ WARNING

Both LP and natural gas have an odorant added to help detection. Some people may not physically be able to smell or recognize this odorant. If unsure or unfamiliar about the smell associated with LP or natural gas, ask the gas supplier. Other conditions, such as "Odorant Fade", which causes the odorant to "fade", or diminish in intensity can also hide or camouflage a gas leak.

⚠ DANGER

Water heaters utilizing Liquefied Petroleum gas (LP) are different from natural gas models. A natural gas heater will not function safely on LP gas and vice versa. No attempt should ever be made to convert a heater from natural gas to LP gas. To avoid possible equipment damage, personal injury or fire: **DO NOT** connect this water heater to a fuel type not in accordance with unit data plate. Propane for propane units. Natural gas for natural gas units. These units are not certified for any other type fuel.

⚠ WARNING

LP appliances should not be installed below-grade (for example, in a basement) if such installation is prohibited by federal, state and/or local laws, rules, regulations or customs.

⚠ General Safety Precautions

To meet commercial water use needs, the thermostat on this water heater is adjustable up to 180°F. However, water temperatures over 125°F. can cause severe burns instantly or death from scalds. This is the preferred starting point for setting the control for supplying general purpose hot water.

Safety and energy conservation are factors to be considered when setting the water temperature on the thermostat. The most energy efficient operation will result when the temperature setting is the lowest that satisfies the needs consistent with the application. Maximum water temperatures occur just after burner has shut off.

The following chart details the relationship of water temperature and time with regard to scald injury and may be used as a guide in determining the safest water temperature for your applications.

TIME / TEMPERATURE RELATIONSHIPS IN SCALDS

Temperature	Time to Produce Serious Burn
120° F.	More than 5 minutes
125° F.	1 1/2 to 2 minutes
130° F.	About 30 seconds
135° F.	About 10 seconds
140° F.	Less than 5 seconds
145° F.	Less than 3 seconds
150° F.	About 1 1/2 seconds
155° F.	About 1 second

Table courtesy of Shriners Burn Institute

The temperature of the water in the heater can be regulated by setting the temperature dial on front of the thermostat. To comply with safety regulations the thermostat was set at its lowest setting before water heater was shipped from the factory. The illustration below illustrates the thermostat and how to adjust the water temperature.

⚠ DANGER

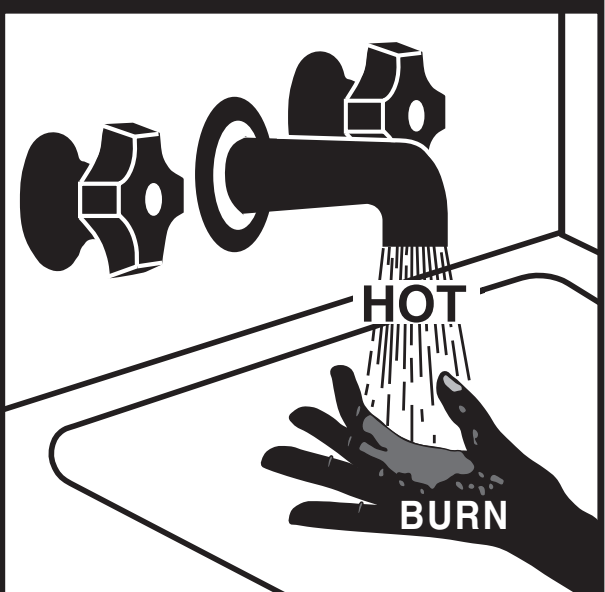

Water temperature over 125°F can cause severe burns instantly or death from scalds.

Children, disabled and elderly are at highest risk of being scalded.

See instruction manual before setting temperature at water heater.

Feel water before bathing or showering.

Temperature limiting valves are available, see manual.

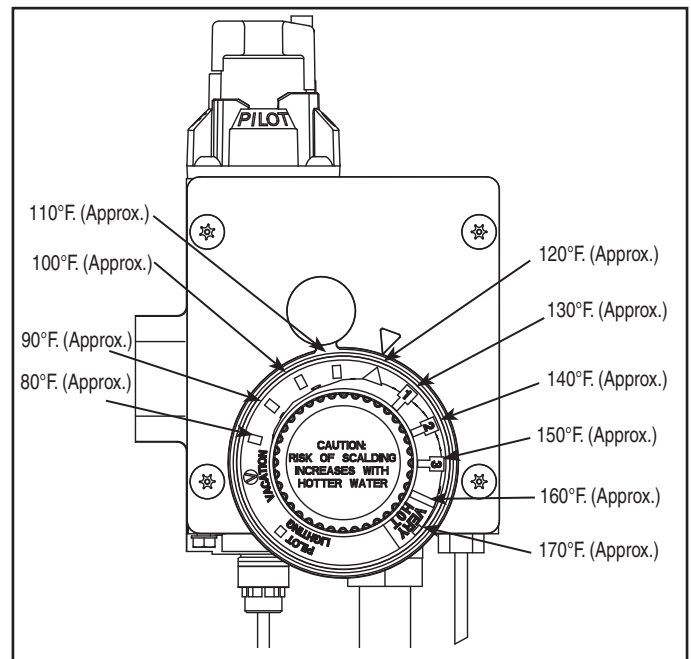

⚠ DANGER

There is a Hot Water SCALD Potential if the thermostat is set too high.

NOTE: When this water heater is supplying general purpose hot water requirements for use by individuals, a thermostatically controlled mixing valve for reducing point of use water temperature is recommended to reduce the risk of scald injury. Contact a licensed plumber or the local plumbing authority for further information.

To find hot water temperature being delivered, turn on a hot water faucet and place a thermometer in the hot water stream and read the thermometer.

Introduction

⚠ WARNING

Read and Review this entire Manual with special emphasis on the Venting Section (Page 6) and Operation Section (Pages 8 - 10) prior to any installation work.

The location chosen for the water heater must take into consideration the following:

LOCAL INSTALLATION REGULATIONS

This water heater must be installed in accordance with these instructions, local codes, utility company requirements, and/or in the absence of local codes, the latest edition of the American National Standard / National Fuel Gas Code. A copy can be purchased from either American Gas Association, 400 N. Capitol Street, N. W., Washington, DC 20001 or from their web site (www.aga.org) as booklet Z22399-IN1 or National Fire Prevention Association, 1 Batterymarch Park, Quincy, MA 02269 or from their web site (www.nfpa.org) as Item # 54HB99.

LOCATION:

A. A gas fired water heater should not be installed in a space where liquids which give off flammable vapors are to be used or stored. Such liquids include gasoline, LP gas (butane and propane), paint or adhesives and their thinners, solvents or removers. Because of natural air movement in a room or other enclosed space, flammable vapors can be carried some distance from where their liquids are being used or stored. The open flame of the water heater's pilot light or main burner can ignite these vapors causing an explosion or fire which may result in severe burns or death to those in range, as well as property damage. For these reasons, installation of a gas fired water heater in a garage is not desirable.

⚠ WARNING

If a location in a garage is the only alternative, the gas water heater should be installed so that the open flame of the pilot and main burner are no less than 18 inches above the garage floor, unless specifically exempted from this by local code, rule, regulation or custom. Raising the gas fired water heater will reduce but not eliminate the possibility of lighting the vapor of any flammable liquids which may be improperly stored or accidentally spilled.

The water heater must be located or protected so it is not subject to physical damage, for example, by moving vehicles, area flooding etc.

Stand Kits to raise the water heater the required 18" above the floor are available from the distributor or store where the water heater was purchased.

B. The water heater should be installed as close as practical to the gas vent or chimney. Long hot water lines should be insulated to conserve water and energy. The water heater and water lines should be protected from exposure to freezing temperatures. DO NOT install the water heater in bathrooms, bedrooms, any occupied rooms normally kept closed, or in outdoor unprotected areas.

C. Minimum clearance from combustible construction is 1 inch sides and rear; 3 inches from front of control; 12 inches top. If clearances stated on the Instruction/Warning label, located on front of heater differ from the aforementioned clearances, install heater according to clearances stated on the Instruction/Warning label. The water heater

may be installed on combustible floors, but not directly on carpeting. If the water heater must be installed on carpeting, place a metal or wood panel beneath the water heater extending beyond its full width and depth at least 3 inches in all directions. If the water heater is installed in an alcove, the entire floor must be covered by the panel. A minimum of 24 inches clearance from the front and top should be available for adequate inspection and servicing.

⚠ WARNING

"Combustible construction" refers to adjacent walls and ceilings, and should not be confused with combustible or flammable products and materials. Combustible and/or flammable products and materials should never be stored in the vicinity of this or any gas appliance.

⚠ CAUTION

The water heater should not be located in an area where leakage of the tank or connections will result in damage to the area adjacent to it or to lower floors of the structure. When such areas cannot be avoided, it is recommended that a suitable catch pan, adequately drained, be installed under the water heater. The pan MUST NOT restrict combustion air flow to bottom of water heater.

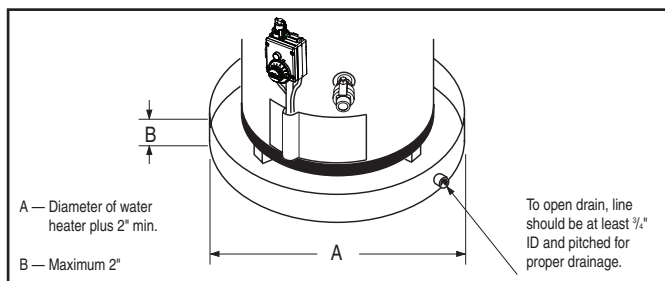

Figure 1. — Auxiliary Catch Pan

NOTE: Auxiliary catch pan installation MUST conform to local codes.

Catch Pan Kits are available in 16", 19", 22", 24", and 26 1/2" diameters from the distributor or store where the water heater was purchased.

D. **RESTAURANTS** — If the water heater is to be installed in a restaurant or other location where the floor is frequently cleaned, it must be elevated to provide at least six inches (15cm) of clearance from the floor to comply with NSF /UL Sanitation recommendations. A factory-designed leg extension kit is available for this purpose from the distributor or store where the water heater was purchased.

E. **COMBUSTION & VENTILATION AIR** — Proper operation of the water heater requires outside air for combustion and ventilation. If the water heater is installed in an unconfined space within a building of conventional frame, masonry or metal construction, infiltration air is normally adequate for proper combustion and ventilation.

However, if the space is confined, provisions for this air must be made. A confined space is one having a volume of less than 50 cubic feet per 1000 Btu/hr of the aggregate input of all appliances within that space. The air must be supplied through two permanent openings of equal area, one of which is to be located within 12 inches above the floor and the other is to be located within 12 inches below the ceiling. The minimum net free area of each opening must be not less than one square inch per 1000 Btu/hr of the total input rating of all the

Introduction

appliances in the enclosure (but not less than 100 square inches), if each opening communicates with other unconfined areas inside the building. Buildings of unusually tight construction shall have the combustion and ventilation air supplied from outdoors or a freely ventilated attic or crawl space.

If air is supplied from outdoors, directly or through vertical ducts, there must be two openings located as specified above and each must have a minimum net free area of not less than one square inch per 4000 Btu/hr of the total input rating of all the appliances in the enclosure.

If horizontal ducts are used to communicate with the outdoors, however, each opening must have a minimum net free area of not less than one square inch per 2000 Btu/hr of the total input rating of all the appliances in the enclosure. If ducts are used, the minimum dimension of rectangular air ducts shall be not less than 3 inches.

NOTE: If the openings are to be covered with a protective screen or grill, the net free area of the covering material must be used in determining the size of the openings, as stated above. Protective screening for the openings MUST NOT be smaller than 1/4 inch mesh to resist clogging by lint or other debris.

Provisions for combustion and ventilation air must comply with referenced codes and standards. See Local Installation Regulations Section on Page 4.

F. CORROSIVE ATMOSPHERES—The water heater should not be installed near an air supply containing halogenated hydrocarbons. For example, the air in beauty shops, drycleaning establishments, photo processing labs, and storage areas for liquid and powdered bleaches or swimming pool chemicals often contain such hydrocarbons. The air there maybe safe to breathe, but when it passes through a gas flame, corrosive elements are released that will shorten the life of any gas burning appliance. Propellants from common spray cans or gas leaks from refrigeration equipment are highly corrosive after passing through a flame. The limited warranty is voided when failure of water heater is due to a corrosive atmosphere. (Reference is made to the limited warranty for complete terms and conditions.

Installation

1. INSPECT SHIPMENT—Inspect water heater for possible shipping damage. Check the marking of the rating plate of the water heater to be certain the type of gas being furnished corresponds to that for which the water heater is equipped.

2. THERMAL EXPANSION — Determine if a check valve exists in the inlet water line. It may have been installed in the cold water line as a separate back flow preventer, or it may be part of a pressure reducing valve, water meter or water softener. A check valve located in the cold water inlet line can cause what is referred to as a **"closed water system"**. A cold water inlet line with no check valve or back flow prevention device is referred to as an **"open"** water system.

As water is heated, it expands in volume and creates an increase in the pressure within the water system. This action is referred to as **"thermal expansion"**. In an **"open"** water system, expanding water which exceeds the capacity of the water heater flows back into the city main where the pressure is easily dissipated.

A **"closed water system"**, however, prevents the expanding water from flowing back into the main supply line, and the result of **"thermal expansion"** can create a rapid, and dangerous pressure increase in the water heater and system piping. This rapid pressure increase can quickly reach the safety setting of the relief valve, causing it to operate during each heating cycle. Thermal expansion, and the resulting rapid, and repeated expansion and contraction of components in the water heater and piping system can cause premature failure of the relief valve, and possibly the heater itself. Replacing the relief valve **will not** correct the problem!

The suggested method of controlling thermal expansion is to install an expansion tank in the cold water line between the water heater and the check valve. (refer to Figure 2.) The expansion tank is designed with an air cushion built in that compresses as the system pressure increases, thereby relieving the over pressure condition and eliminating the repeated operation of the relief valve. Other methods of controlling thermal expansion are also available. Contact your installing contractor, water supplier, or plumbing inspector for additional information regarding this subject.

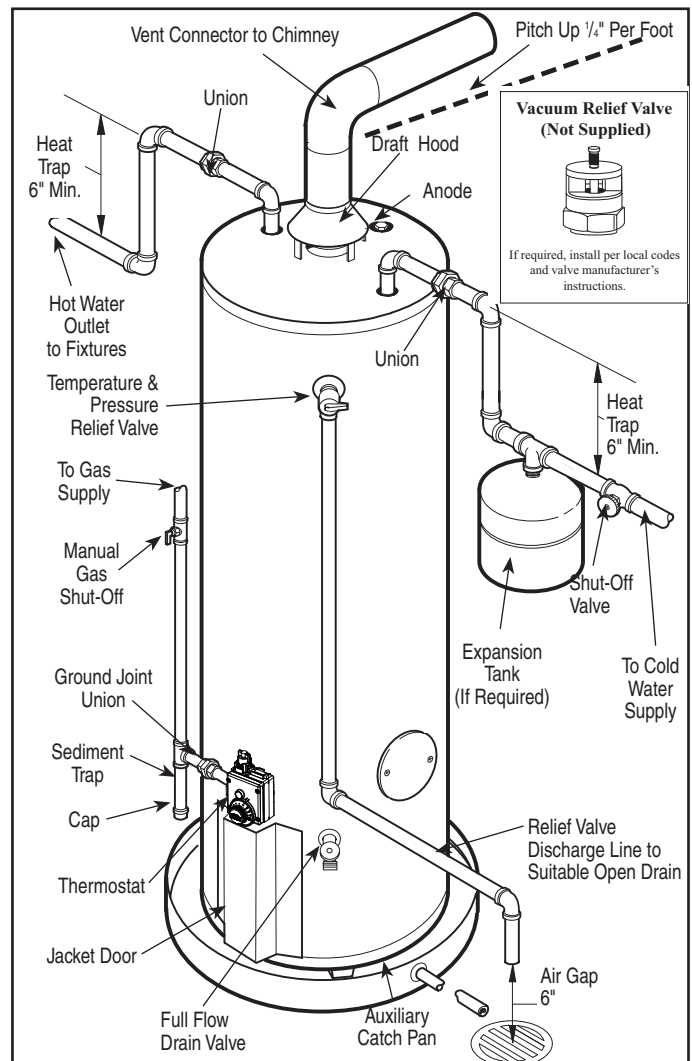

Figure 2 — Typical Installation

Installation

WATER SUPPLY CONNECTIONS— Refer to Fig. 2 for suggested typical installation. The installation of unions or flexible copper connectors is recommended on the HOT and COLD water lines, so that the water heater may be easily disconnected for servicing if necessary. The HOT and COLD water connections are clearly marked.

Install a shut-off valve in the cold water line near water heater.

IMPORTANT!! Do not apply heat to the hot or cold heat trap nipples. If sweat connections are used, sweat tubing to adapter before fitting adapter to hot water outlet or cold water inlet of heater. Any heat applied to the inlet or outlet will permanently damage the heat trap fittings supplied with the water heater or the dip tube.

- 3. RELIEF VALVE**—A new combination pressure and temperature relief valve, complying with the Standard for Relief Valves and Automatic Gas Shutoff Devices for Hot Water Supply Systems, ANSI Z21.22, or Standard CAN1-4.4, Temperature, Pressure, Temperature and Pressure Relief Valves and Vacuum Relief Valves is provided with the water heater. No valve is to be installed between the relief valve and the water heater. The pressure rating of the relief valve must not exceed 150 PSI, the maximum working pressure of the water heater as marked on the front of the water heater.

The Btu/hr rating of the relief valve must equal or exceed the Btu/hr input of the water heater as marked on its rating plate.

Connect the outlet of the relief valve to a suitable open drain. Piping used should be of a type approved for hot water distribution. The discharge line must be no smaller than the outlet of the valve and must pitch downward from the valve to allow complete drainage (by gravity) of the relief valve and discharge line. The end of the discharge line should not be threaded or concealed and should be protected from freezing. No valve of any type, restriction or reducer coupling should be installed in the discharge line.

- 4. TO FILL WATER HEATER**—Make certain drain valve is closed. Open shut-off valve in cold water supply line. Open each hot water faucet slowly to allow air to vent from the water heater and piping. A steady flow of water from the hot water faucet(s) indicates a full water heater

WARNING

Tank MUST be full of water before water heater is turned on. The water heater's warranty does not cover damage or failure resulting from operation with an empty or partially empty tank (dry fired).

- 5. GAS SUPPLY**—The branch gas supply line to the water heater should be clean $\frac{1}{2}$ " black steel pipe or other approved gas piping material. A ground joint union or ANSI design certified semi-rigid or flexible gas appliance connector should be installed in gas line close to the water heater, and a manual gas shut-off valve should be installed in the gas line prior to the union. The manual gas shut-off valve should be readily accessible for turning on or off. A sediment trap should be installed at bottom of the gas line. (Refer to Fig. 2)

Compound used on threaded joints of the gas piping must be of the type resistant to the action of liquefied petroleum gas. Use compound sparingly on male threads only. Do not use excessive force (over 31.5 Ft. Lbs.) in

tightening the pipe joint at the thermostat inlet, particularly if teflon pipe compound is used, as the valve body may be damaged.

The inlet gas pressure to the water heater must not exceed 14" w.c. for Natural or L.P. gas. For purposes of input adjustment, the minimum inlet gas pressure (with main burner on) is shown on the water heater rating plate. If high or low gas pressures are present, contact your gas supplier for correction.

WARNING

Do not attempt to convert this water heater for use with a different type of gas other than the type shown on the rating plate. Such conversion could result in hazardous operating conditions.

- 6. LEAK TESTING**—The water heater and its gas connections must be leak tested at normal operating pressures before it is placed in operation. Turn on the manual gas shut-off valve near the water heater (Refer to Fig.2). Use a soapy water solution to test for leaks at all connections and fittings. Bubbles indicate a gas leak that must be corrected. The factory connections to the thermostat should also be leak tested after the water heater is placed in operation.

WARNING

Never use open flame to test for gas leaks, as bodily injury, property damage or death could result.

PRESSURE TESTING THE GAS SUPPLY SYSTEM — The water heater and its manual gas shut-off valve must be disconnected from the gas supply piping system during any high pressure testing of that system at pressures in excess of $\frac{1}{2}$ psi (14" W.C.).

The water heater must be isolated from the gas piping system by closing the manual gas shut-off valve (Refer to Fig. 2), during any pressure testing of the gas supply piping at pressures equal to or less than $\frac{1}{2}$ psi (14" W.C.).

- 7. VENTING**—This water heater must be installed with the factory supplied draft hood in place. (Refer to Fig. 2.) Vent connectors must be attached to the draft hood outlet to connect the water heater to the gas vent or chimney. The vent connectors must be the same size (diameter) as the draft hood outlet or larger, never smaller. For proper venting in certain installations, a larger vent connector size may be needed. Consult Vent Tables in Appendix "G" of the latest version of the National Fuel Gas Code or NFPA booklet Z22399-IN1 .

Horizontal vent connectors must be pitched upward to the chimney at least $\frac{1}{4}$ " per foot of length. Single wall vent connectors must be at least 6" from adjacent unprotected combustible surfaces. Joint of vent connectors should be securely fastened by sheet metal screws or other approved method.

DANGER

Failure to install the draft hood and properly vent the water heater to the outdoors as outlined above can result in unsafe operation of the water heater causing bodily injury, explosion, fire or death. To avoid the risk of fire, explosion, or asphyxiation from carbon

Installation

monoxide, **NEVER operate this water heater unless it is properly vented and has an adequate air supply for proper operation.**

Be sure to inspect the vent system for proper installation at initial start-up and at least annually thereafter. Refer to Maintenance section of this manual for more information regarding vent system inspections.

WARNING

The manufacturer's warranty does not cover any damage or defect caused by installation, attachment or use of any type of energy saving or other unapproved devices (other than those authorized by the manufacturer) into, onto or in conjunction with the water heater. The use of unauthorized energy saving devices may shorten the life of the water heater and may endanger life and property. The manufacturer disclaims any responsibility for such loss or injury resulting from the use of such unauthorized devices.

If local codes require external application of insulation blanket kits, the instructions included with the kit must be carefully followed.

WARNING

Application of any external insulation to this water heater will require careful attention to the following:

- Do not apply insulation to top of water heater, as this will interfere with the safe operation of the draft hood.
- Do not cover burner access panel, thermostat/gas valve or pressure and temperature relief valve.
- Do not cover operating instructions or warning labels attached to the water heater nor attempt to relocate them on the exterior of the insulation blanket.
- Do not apply insulation to bottom or the 2" space between the bottom pan of the water heater and the floor, as this area must be unobstructed so as not to restrict combustion air flow to the burner.
- Do inspect the insulation blanket frequently to make certain it has not sagged and is restricting the combustion air to the bottom of the water heater, as this could result in an unsafe operating condition.

Installation Check List

A. Water Heater Location

- Close to area of vent.
- Indoors and protected from freezing temperatures.
- Proper clearance from combustible surfaces observed and water heater not installed on carpeted floor.
- Sufficient fresh air supply for proper operation of water heater.
- Air supply free of corrosive elements and flammable vapors.
- Provisions made to protect area from water damage.
- Sufficient room to service heater.

B. Water Supply

- Water heater completely filled with water.
- Water heater and piping air vented.
- Water connections tight and free of leaks.

C. Gas Supply

- Gas line equipped with shut-off valve, union, and sediment trap/drip leg.

- Approved pipe joint compound used.
- Soap and water solution used to check all connections and fittings for possible gas leak.
- Gas Company inspected installation (if required).

D. Relief Valve

- Discharge line run to open drain.
- Discharge line protected from freezing.

E. Venting

- Flue baffle properly hung in top of heater's flue.
- Draft hood properly installed.
- Vent connector(s) pitched upward to chimney ($\frac{1}{4}$ " per foot of length minimum).
- Vent connector(s) securely fastened together with screws.
- Single wall vent connector(s) at least 6" from combustible material.

Operation

Before operating this water heater, be sure to read and follow the instructions on the label pictured below and all other labels on the water heater, as well as the warnings printed in this manual. Failure to do so can result in unsafe operation of the water heater resulting in property damage, bodily injury, or death. Should you have any problems reading or following the instructions in this manual, STOP, and get help from a qualified person.







1. LIGHTING PROCEDURE - Lighting procedures are outlined on the label pictured below. This label is also located on the water heater near the thermostat.

FOR YOUR SAFETY READ BEFORE OPERATING

⚠ WARNING: If you do not follow these instructions and the Use & Care Manual instructions exactly, a fire or explosion may result causing property damage, personal injury or loss of life.



- A. This appliance has a pilot which must be lighted by hand. When lighting the pilot, follow these instructions exactly.
- B. **WHAT TO DO IF YOU SMELL GAS:**
 - Do not try to light any appliance.
 - Do not touch any electric switch; do not use any phone in your building.
 - Immediately call your gas supplier from a neighbor's phone. Follow the gas supplier's instructions.
 - If you cannot reach your gas supplier, call the fire department.
- C. Use only your hand to turn the gas control knob. Never use tools. If the knob will not turn by hand, don't try to repair it, call a qualified service technician. Force or attempted repair may result in a fire or explosion.
- D. Do not use this appliance if any part has been under water. Immediately call a qualified service technician to inspect the appliance and replace any part of the control system which has been under water.

LIGHTING INSTRUCTIONS

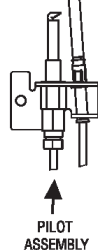
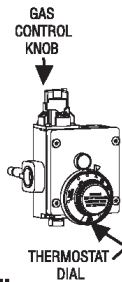
1. STOP! Read safety information above on this label.
2. Set the thermostat dial to the lowest setting "PILOT LIGHTING" by turning the thermostat dial clockwise  until it stops.
3. Slightly depress the gas control knob and turn clockwise  to "OFF" position. Note: Knob cannot be turned from "PILOT" position unless pushed down slightly. Do not force.
4. Wait five (5) minutes to clear out any gas. If you smell any gas, STOP! Follow "B" in the safety information above on this label. If you do not smell gas, go to the next step.
5. Remove both the outer door and the inner door from the heater.
6. Follow the metal tubes from the gas control through the door openings. The pilot is located on the horizontal leg of the larger tube (or burner).
7. Turn the gas control knob counter-clockwise  to the "PILOT" position.
8. Depress and hold the gas control knob all the way down. Light the pilot with a match. The pilot flame can be seen through the door opening.
9. Continue to hold down the gas control knob for about one (1) minute after the pilot is lit. If it goes out repeat steps 3 to 9.
 - If the gas control knob does not pop up when released, stop and immediately call your service technician or gas supplier.
 - If the pilot will not stay lit after several tries, turn the gas control knob clockwise  to "OFF" and call your service technician or gas supplier.
10. Once the pilot flame is established replace the inner and outer doors.
11. Turn the gas control knob counter-clockwise  to the "ON" position.
12. Set the thermostat dial to desired setting. The preferred starting point for temperature is indicated by  on the thermostat dial.



TO TURN GAS OFF TO THE APPLIANCE

1. Set the thermostat dial to the lowest setting "PILOT LIGHTING" by turning the thermostat dial clockwise  until it stops.
2. Slightly depress the gas control knob and turn clockwise  to "OFF POSITION". Note: Knob cannot be turned from "PILOT" position unless pushed down slightly. Do not use force.

SAFETY PRECAUTIONS

- A. **Do** turn off manual gas shut-off valve if water heater has been subjected to over heating, fire, flood, physical damage, or if gas supply fails to shut off.
- B. **Do Not** turn on water heater unless it is filled with water.
- C. **Do Not** turn on water heater if cold water supply shut-off valve is closed.
- D. Do Not store or use gasoline or other flammable vapors and liquids, such as adhesives or paint thinner, in vicinity of this or any other appliance. If such flammables must be used, open doors and windows for ventilation, and all gas burning appliances in vicinity should be shut off, including their pilot lights, to avoid igniting vapors that may be present.

NOTE: Flammable vapors may be drawn by air currents from surrounding areas to the water heater.

- E. **Do not** allow combustible materials such as newspaper, rags, or mops to accumulate near water heater.
- F. If there is any difficulty in understanding or following the OPERATION or MAINTENANCE instructions, it is recommended that a qualified person or serviceman perform the work.

CAUTION

Hydrogen gas can be produced in a hot water system served by this water heater that has not been used for a long period of time (generally two weeks or more). HYDROGEN GAS IS EXTREMELY FLAMMABLE!! To dissipate such gas and to reduce risk of injury, it is recommended that the hot water faucet be opened for several minutes at the kitchen sink before using any electrical appliance connected to the hot water system. If hydrogen is present, there will probably be an unusual sound such as air escaping through the pipe as the water begins to flow. Do not smoke or use an open flame near the faucet at the time it is open.

2. WATER TEMPERATURE SETTING— The temperature of the water in the heater can be regulated by setting the temperature dial on front of the thermostat. (Refer to Fig. 3) To comply with safety regulations the thermostat was set at its lowest setting before water heater was shipped from the factory. A setting of 120°F., or lower if local codes require, is recommended as a starting point.

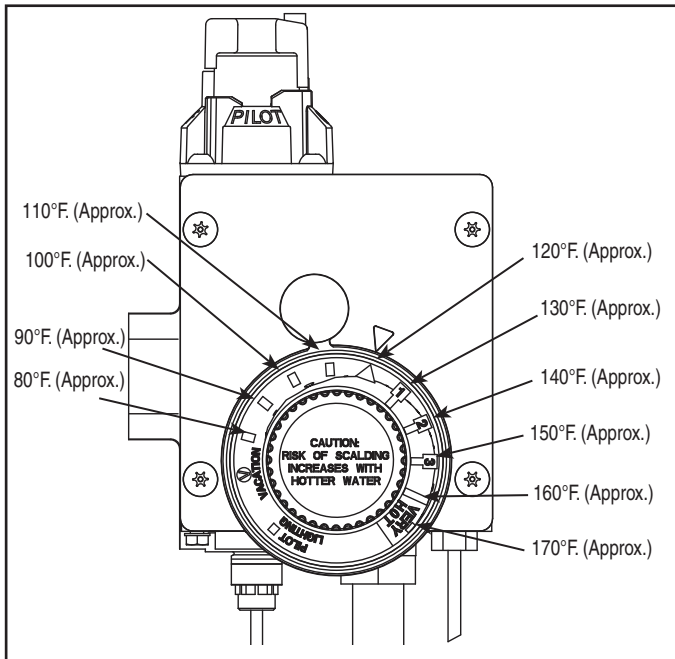

Figure 3 — Thermostatic Gas Valve.

The “TRIANGLE” reference mark on rim of temperature dial, represents an approximate water temperature of 120°F. The “1” reference mark, to the right, represents an approximate water temperature of 130°F. Each reference mark above or below these points indicates an approximate change of 10°F.

Safety and energy conservation are factors to be considered when selecting the water temperature setting of water heater’s thermostat. The lower the setting the greater the safety and savings in energy and operating cost.

TIME / TEMPERATURE RELATIONSHIPS IN SCALDS

Temperature	Time to Produce Serious Burn
120° F	More than 5 minutes
125° F	1 1/2 to 2 minutes
130° F	About 30 seconds
135° F	About 10 seconds
140° F	Less than 5 seconds
145° F	Less than 3 seconds
150° F	About 1 1/2 seconds
155° F	About 1 second

Table courtesy of Shriners Burn Institute

DANGER

There is a Hot Water SCALD Potential if the thermostat is set too high.

NOTE: Households with small children or invalids may require a 120°F. or lower thermostat setting to prevent contact with “HOT” water.

Maximum water temperatures occur just after burner has shut off. To find hot water temperature being delivered, turn on a hot water faucet and place a thermometer in the hot water stream and read the thermometer.

Operation

Mixing valves for reducing point of use water temperature by mixing hot and cold water in branch water lines are available. Contact a licensed plumber or the local plumbing authority for further information.

- 3. ADJUSTMENTS** - The thermostatic gas valve is equipped for total regulation of the main burner and pilot gas pressures and does not require adjustment.

BURNER ADJUSTMENT — The sheet metal burner does not require adjustment (Refer to Fig. 4)

HIGH ALTITUDE— Ratings of gas appliances are based on sea level operation and need not be changed for installations at elevations up to 2,000 feet. For installations above 2,000 feet, the input must be reduced per the National Fuel Gas Code for each 1,000 feet above sea level. Contact the local gas supplier for further information.

- 4. SAFETY CONTROLS**— The thermostat is constructed with a built in safety shut-off device designed to shut off the gas supply to the burner in the event the pilot flame is extinguished for any reason. The thermostat is also equipped with a single use or resettable gas shut-off device that will shut off the gas supply to the burner, if the water in the water heater exceeds normal operating temperatures. See thermostat label for shut-off device type. Refer to the Troubleshooting Section of this manual, or contact your dealer for service.

5. EMERGENCY SHUTDOWN—

Should overheating occur or the gas supply fail to shut off, turn off the manual gas control valve to the appliance.

If water heater has been subjected to fire, flood, or physical damage turn off the manual gas control (shut-off) valve, and do not operate the water heater again until it has been checked by qualified personnel.

NOTE: Replace any part of the gas control system which has been under water.

- 6. CONDENSATION**— Condensation can form on the tank when it is first filled with cold water. The condensation might also occur with a heavy water draw and very cold inlet water. Drops of water falling on the burner can produce a sizzling or pinging sound, and water may also be seen beneath the water heater. This condition is not unusual, and will disappear after the water in the water heater becomes heated. If, however, the condition is continuous, examine the piping and fittings for possible leaks.

- 7. VACATION AND LONG TIME SHUT-DOWN**— If the water heater is to remain idle for an extended period of time, the gas should be turned off to conserve energy. The water heater and piping should be drained if they might be subjected to freezing temperatures.

NOTE: Refer to Hydrogen Gas Caution, in Safety Precautions Section on page 9.

After a very long shut-down period, the water heater's operation and controls should be checked by qualified service personnel. Make certain the water heater is completely filled before placing it in operation again.

8. DRAINING WATER HEATER—

CAUTION

Shut off gas at thermostat gas cock or supply line manual shut-off valve before draining water from the water heater.

In order to drain water, turn off cold water supply, then it is necessary to open a hot water faucet or lift the handle on the relief valve to admit air to the tank. Attach a garden hose to the drain valve on the water heater and direct the stream of water to a drain where it will do no damage.

DANGER

The water drained from the tank may be hot enough to present a SCALD HAZARD and should be directed to a suitable drain to prevent injury or damage.

- 9. ANODE**— This water heater is equipped with an anode rod designed to prolong the life of the glass lined tank. Refer to Fig.2 for location. The anode rod is slowly consumed cathodically, thereby eliminating or minimizing corrosion of the glass lined tank. Water sometimes contains a high sulfate and/or mineral content and together with the cathodic protection process can produce a hydrogen sulfide or rotten egg odor in the heated water. Chlorination of the water supply should minimize the problem.

NOTE: Do not remove the anode rod from the water heater's tank, except for inspection and/or replacement, as operation with the anode rod removed will greatly shorten the life of the glass lined tank and will exclude warranty coverage.

Maintenance

1. ROUTINE PREVENTATIVE MAINTENANCE

Properly maintained, your water heater will provide years of dependable trouble free service. It is suggested that a regular routine maintenance program be established and followed by the user. It is further recommended that a periodic inspection of the thermostat, burner, relief valve, internal flueway and venting system should be made by service personnel qualified in gas appliance repair.

A. The water heater's internal flue must be inspected annually to be certain it is clean by removing the draft hood and flue baffle. When reinstalling the flue baffle make certain it is hung securely by its hanger at the top of the flue way. Remove any scale that may have fallen on the burner or floor shield. Reinstall the draft hood.

Inspect gas venting system to make certain vent connector from draft hood to chimney is properly positioned and securely attached and inspect chimney. Replace any corroded through vent connector and remove any obstruction in vent connector or chimney.

B. Visually inspect the burner annually while firing and pilot burner flame with main burner off. (Refer to Fig. 4 for normal flame pattern.) If any unusual burner operation is noted, the water heater should be shut off until qualified service assistance can be obtained.

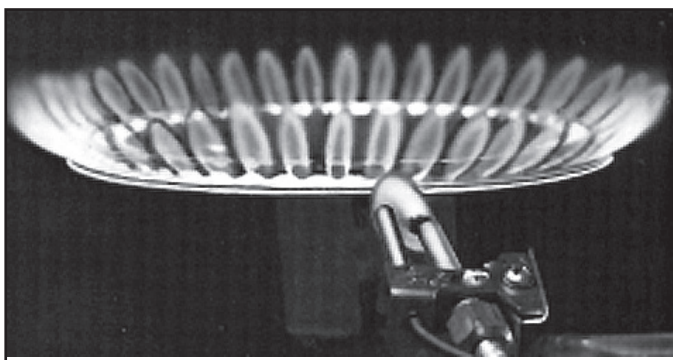

Figure 4. — Main Burner and Pilot Flame Pattern (Sheet Metal Burner)

For cleaning, remove the burner from the water heater. A vacuum cleaner can be used on the burner and floor shield inside the water heater. The burner can also be cleaned by scrubbing with mild detergent.

CAUTION

For your safety, cleaning of main burner should be performed ONLY by qualified service personnel, as it involves disconnection of gas piping and leak testing.

- C.** The area near the water heater must be kept free of flammable liquids such as gasoline or paint thinners, adhesives and other combustible materials.
- D.** For adequate combustion (proper burner operation) and ventilation, make certain the flow of air to the water heater is not obstructed.
- E.** At least once a year, lift and release the lever handle on the temperature pressure relief valve, located near the top of the water heater, to make certain the valve operates freely and allow several gallons to flush through discharge line. Make certain the discharged water is directed to an open drain.

DANGER

Before manually operating the relief valve, make certain no one will be exposed to the danger of coming in contact with the hot water released by this valve. The water may be hot enough to create a SCALD hazard. The water released should be directed to a suitable drain to prevent injury or damage.

NOTE: If the temperature and pressure relief valve on the water heater discharges periodically, this may be due to thermal expansion in a "Closed" water system. Contact the water supplier or your plumbing contractor on how to correct this. DO NOT plug the relief valve outlet.

- F.** A water heater's tank can act as a settling basin for solids suspended in the water. It is, therefore, not uncommon for hard water deposits to accumulate in the bottom of the tank. Deposits should not be allowed to accumulate as this can affect the service life of the water heater. It is suggested that a few quarts of water be drained from the water heater's tank every month. If sufficient hard water deposits accumulate, a rumbling or pounding sound can occur. There is no danger involved and the efficiency of the water heater is not seriously affected, but the noise can be annoying. Your plumbing contractor should be contacted to clean the tank of these deposits.
- G.** Rapid closing of faucets or solenoid valves in automatic water using appliances can cause a pounding "water hammer" sound. "Water hammer" can be described as a banging noise heard in a water pipe following an abrupt alteration of the flow with resulting pressure surges. Strategically located risers in the water pipe system can be used to minimize the problem. Also water hammer arresting devices are usually available from your plumber or local plumbing supply store.

2. ANODE ROD INSPECTION—The anode rod should be removed from the water heater's tank annually for inspection and replaced when more than 6" of core wire is exposed at either end of the rod. Refer to Fig. 2 for anode rod location. Make certain cold water supply is turned off before removing anode rod.

Replacement Parts List

Light Duty Models Natural or LP Gas

Instructions for placing a Parts Order:

Address parts orders to the distributor or store from where the heater was purchased.

All parts orders should include:

1. Model number and Serial number of heater (from rating plate).
2. Specify type of gas (Natural or LP) as listed on rating plate.
3. Part Description (as noted below) and number of parts desired.

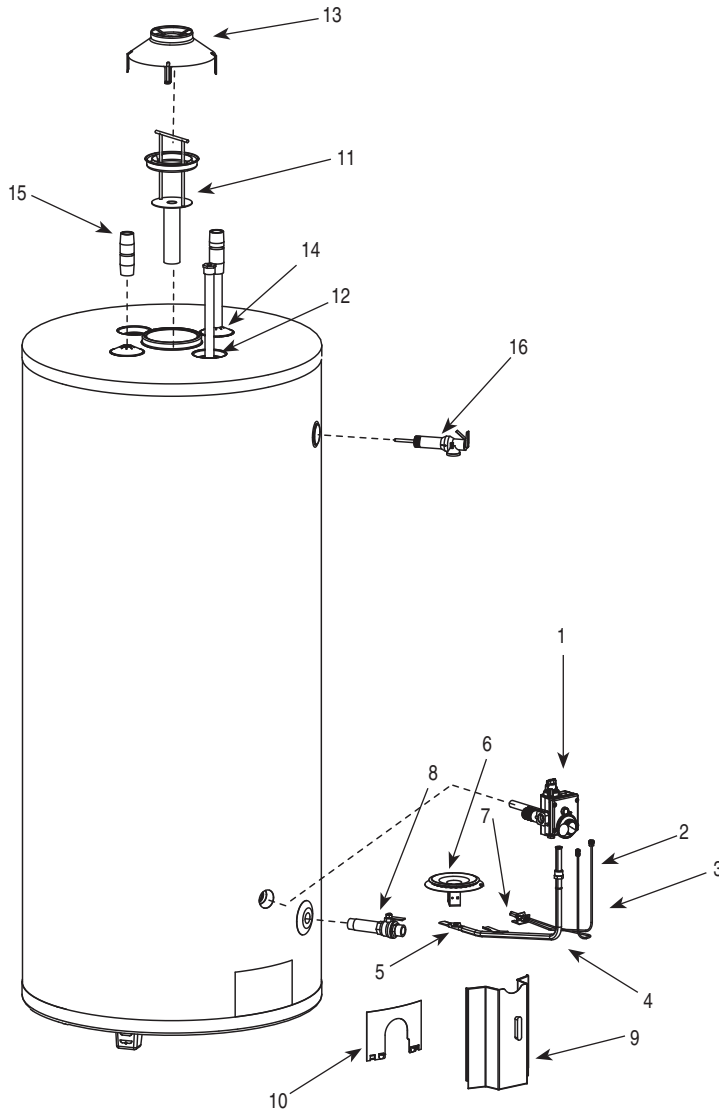

* Top Mounted on Select Models
** Standard Drain Valve on Select Models

CAUTION

For your safety, DO NOT attempt repair of gas piping, thermostat, burners, vent connectors or other safety devices. Refer repairs to qualified service personnel.

Replacement Parts List

Light Duty Models Natural or LP Gas

Instructions for placing a Parts Order:

Address parts orders to the distributor or store from where the heater was purchased.

All parts orders should include:

1. Model number and Serial number of heater (from rating plate).
2. Specify type of gas (Natural or LP) as listed on rating plate.
3. Part Description (as noted below) and number of parts desired.

Ref. No.	Part Description	Qty. Req'd
1.	Thermostat	1
2.	Pilot Supply Tube	1
3.	Thermocouple	1
4.	Burner Supply Tube	1
5.	Burner Orifice	1
6.	Burner	1
7.	Pilot Burner	1
8.	Drain Valve	1
9.	Jacket Door	1
10.	Inner Door	1
11.	Flue Baffle and Collar	1
12.	Anode Rod	2
13.	Draft Hood	1
14.	Dip Tube	1
15.	Outlet Nipple	1
16.	T&P Relief Valve	1

Trouble Shooting Guide

NATURE OF TROUBLE	POSSIBLE CAUSE	SERVICE
Unable to light pilot	<ol style="list-style-type: none"> 1. Gas knob dial not correctly positioned 2. Pilot orifice clogged 3. Pilot tube pinched or clogged. 4. Air in gas line 	Follow lighting instructions ** Clean or replace ** Clean, repair or replace ** Purge air from gas line
Pilot does not stay lit when gas control knob is released	<ol style="list-style-type: none"> 1. Loose Thermocouple 2. Thermocouple breakdown 3. Safety magnet breakdown 4. Thermostat's single use gas shut-off device has opened (See Thermostat labels) Or Thermostat's resettable gas shut-off has opened (See Thermostat label) 	** Tighten connection at thermostat ** Replace ** Replace thermostat ** Replace thermostat Or Allow water to cool before lighting
Not enough hot water	<ol style="list-style-type: none"> 1. Heater undersized 2. Low gas pressure 	Reduce rate of hot water usage ** Check gas supply pressure and manifold pressure
Water too hot or not hot enough	<ol style="list-style-type: none"> 1. Thermostat setting too high or low 2. Thermostat out of calibration 3. High water temperature followed by pilot outage. 	Change setting as required ** Replace ** Thermostat out of calibration, replace
Yellow flame Sooting	<ol style="list-style-type: none"> 1. Scale on top of burner 2. Combustion air inlets or flueway restricted 3. Not enough combustion or ventilation air supplied to the room 	Shut off heater and remove scale Remove lint or debris and inspect air inlet opening for restriction Refer to Sec. E in Introduction section of this manual
Rumbling noise	<ol style="list-style-type: none"> 1. Scale or sediment in tank 	Clean tank - See Maintenance, Sec.F
Rattling noise during periods of water usage	<ol style="list-style-type: none"> 1. Heat Trap fittings in operation (If heater is equipped with these energy saving devices) 	None. The rattling noise is normal for Heat Trap fittings when in operation and does not indicate a need for service.

⚠ CAUTION

**** For your safety, DO NOT attempt repair of thermostat, burners or gas piping. Refer repairs to qualified service personnel.**

How to Obtain Service Assistance

1. Should you have any questions about your new water heater, or if it requires adjustment, repair, or routine maintenance, it is suggested that you first contact your installer, plumbing contractor or previously agreed upon service agency. In the event that the firm has moved, or is unavailable, refer to the telephone directory commercial listings or local utility for qualified service assistance.

2. Should your problem not be solved to your complete satisfaction, you should then contact the Manufacturer's National Service Department at the following address:

2600 Gunter Park Drive
 Montgomery, Alabama 36109-1413
 Phone: 1-800-432-8373.

When contacting the manufacturer, the following information should

be made available:

- a. Model and serial numbers of the water heater as shown on the rating plate attached to the jacket of the heater.
- b. Address where water heater is located and can be seen.
- c. Name and address of installer and any service agency who performed service on the water heater.
- d. Date of original installation and dates any service work was performed.
- e. Details of the problem as you can best describe them.
- f. List of people, with dates, who have been contacted regarding your problem.

THIS PAGE WAS INTENTIONALLY LEFT BLANK.

THIS PAGE WAS INTENTIONALLY LEFT BLANK.