

Signature Pro

Dual Stage Snowthrowers

Attachment

Mfg. No.	Description
1695989	P1524E, 14.5GT 24" Dual Stage Snowthrower
1695990	(P1728E), 16.5TP 28" Dual Stage Snowthrower
1695991	(P1732E), 16.5GT 32" Dual Stage Snowthrower
1695992	(P1738E), 16.5GT 38" Dual Stage Snowthrower

PRODUCT COMPONENTS	PAGES
Handles & Controls Group	4
Engine & Frame Group	8
Auger Drive Group - Heavy Duty	12
Auger Housing Group	14
Traction Drive Group	16
Wheels & Tires Group	20
Decals Group	22
Chute & Rotation Group - Electric Chute/Remote Deflector	24
Gear Case Assembly - Heavy Duty	26
Torque Specification Chart	Inside Back Cover

Not for
Reproduction

Handles & Controls Group

NOTE: Unless noted otherwise,
use the standard hardware torque
specification chart.

2988283

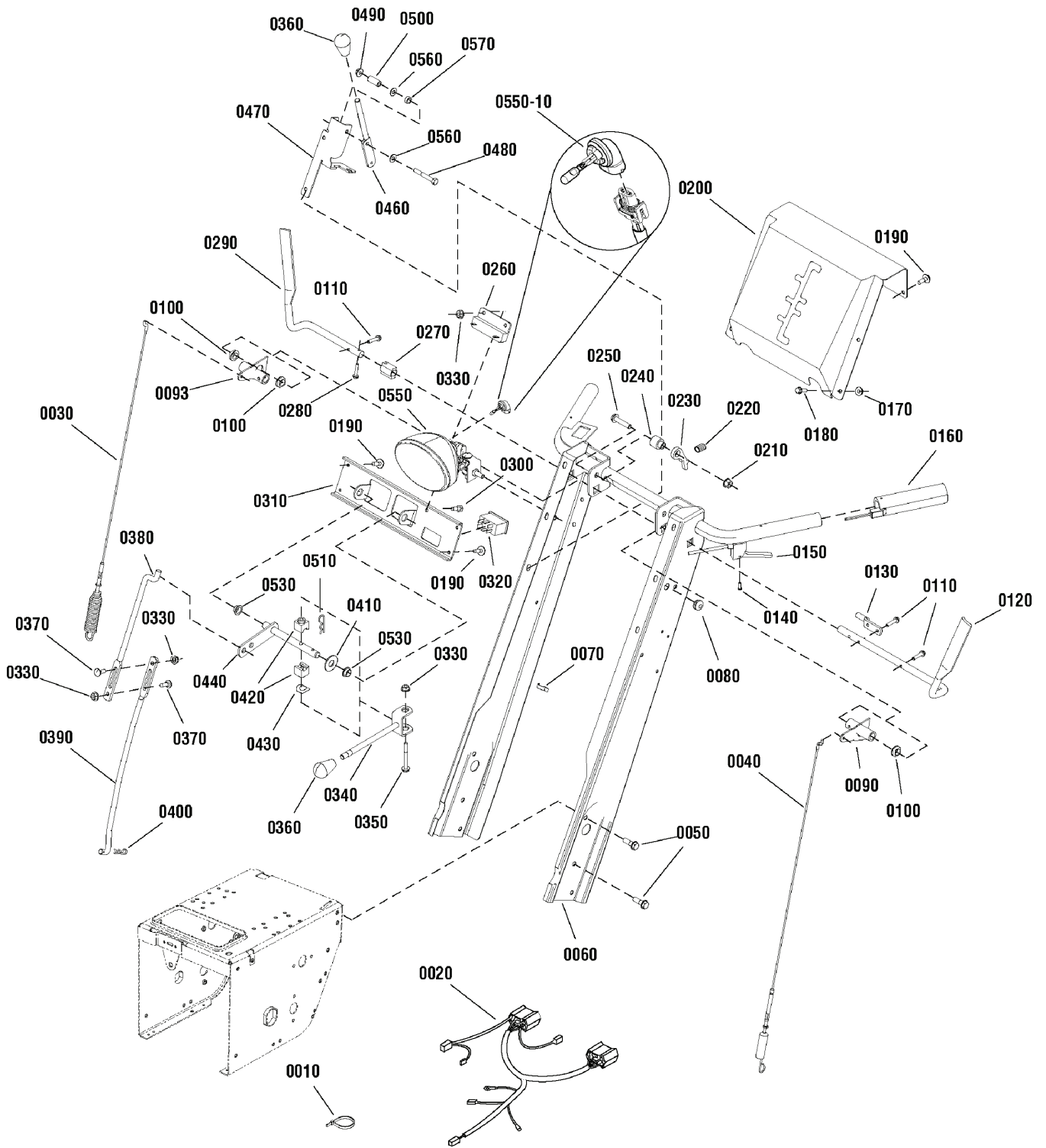

The above parts group applies to the following Mfg. Nos.:

- 1695989 - P1524E
- 1695990 - (P1728E)
- 1695991 - (P1732E)
- 1695992 - (P1738E)

Handles & Controls Group

REF NO	PART NO.	QTY.	DESCRIPTION
0010	1701011	5	TIE, Self Lock
0020	1728968	1	HARNESS, Wiring
0030	1735148	1	CABLE & SPRING ASSEMBLY, Auger, R.H.
0040	1728115	1	CABLE & SPRING ASSEMBLY, Traction, L.H.
0050	1664847	6	CAPSCREW, Hex Flange, 5/16-18 x 3/4
0060	1733890C	1	HANDLE ASSEMBLY
0070	2834683	2	CLIP, Wire
0080	1664022	1	GROMMET
0090	1725205A	1	LEVER, Clutch, L.H
0093	1735133A	1	LEVER, Clutch, R.H.
0100	1732732	3	BUSHING
0110	1960471	4	CAPSCREW, Hex Washer Head, Taptite, #12-24 x 1
0120	1727127	1	HANDLE, Clutch, L.H.
0130	1677453	1	ROD, Control, 2-7/8
0140	1725702	1	SCREW, Pan Head Torx, #10 x 1/2
0150	1718791	1	CABLE & HANDLE ASSEMBLY
0160	1723965	2	GRIP, Hand, Heated
0170	1930641	4	NUT, Hex Flange, Whiz Lock, 1/4-20
0180	1935450	4	CAPSCREW, Hex Flange Head, 1/4-20 x 3/4
0190	1925592	6	CAPSCREW, Hex Washer Head, Taptite, 1/4-20 x 3/4
0200	1734387C	1	DASH, Handle
0210	1960686	1	NUT, Hex Flange, ESNA, 5/16-18
0220	1701342	1	SPRING, Compression
0230	1705898	1	LATCH, Control
0240	1678579	1	SPACER
0250	1933689	1	CAPSCREW, Hex Flange, Whiz Lock, 5/16-18 x 1-1/2
0260	1724037	1	RESISTOR BLOCK
0270	1705899	1	GUIDE, Control
0280	1928732	1	SCREW, Hex Washer Head, Taptite, #10-24 x 1
0290	1727128	1	HANDLE, Clutch, R.H.
0300	1923341	1	CAPSCREW, Hex Flange Head, 1/4-20 x 3/4
0310	1723935	1	BRACKET, Shift Control
0320	1723967	1	SWITCH, Hand Warmer
0330	1960685	4	NUT, Hex Keps, 1/4-20
0340	1668523	1	ROD & CLEVIS ASSEMBLY
0350	1960705	1	CAPSCREW, Hex Flange, Whiz Lock, 1/4-20 x 2-1/4
0360	1732470	2	KNOB
0370	1931317	2	BOLT, Carriage, 1/4-20 x 3/4
0380	1734388	1	ROD, Shift, Upper, 10-1/2
0390	1666255	1	ROD, Shift, 15-5/16
0400	1722460	1	PIN, Quick
0410	1924361	1	WASHER, 1/2
0420	1668524	2	BLOCK, Pivot
0430	1668681	1	WASHER, Curved

Footnotes

Note* See your local hardware store for replacement bulbs.

The above parts group applies to the following Mfg. Nos.:

1695989 - P1524E
1695990 - (P1728E)
1695991 - (P1732E)
1695992 - (P1738E)

Handles & Controls Group

NOTE: Unless noted otherwise,
use the standard hardware torque
specification chart.

2988283

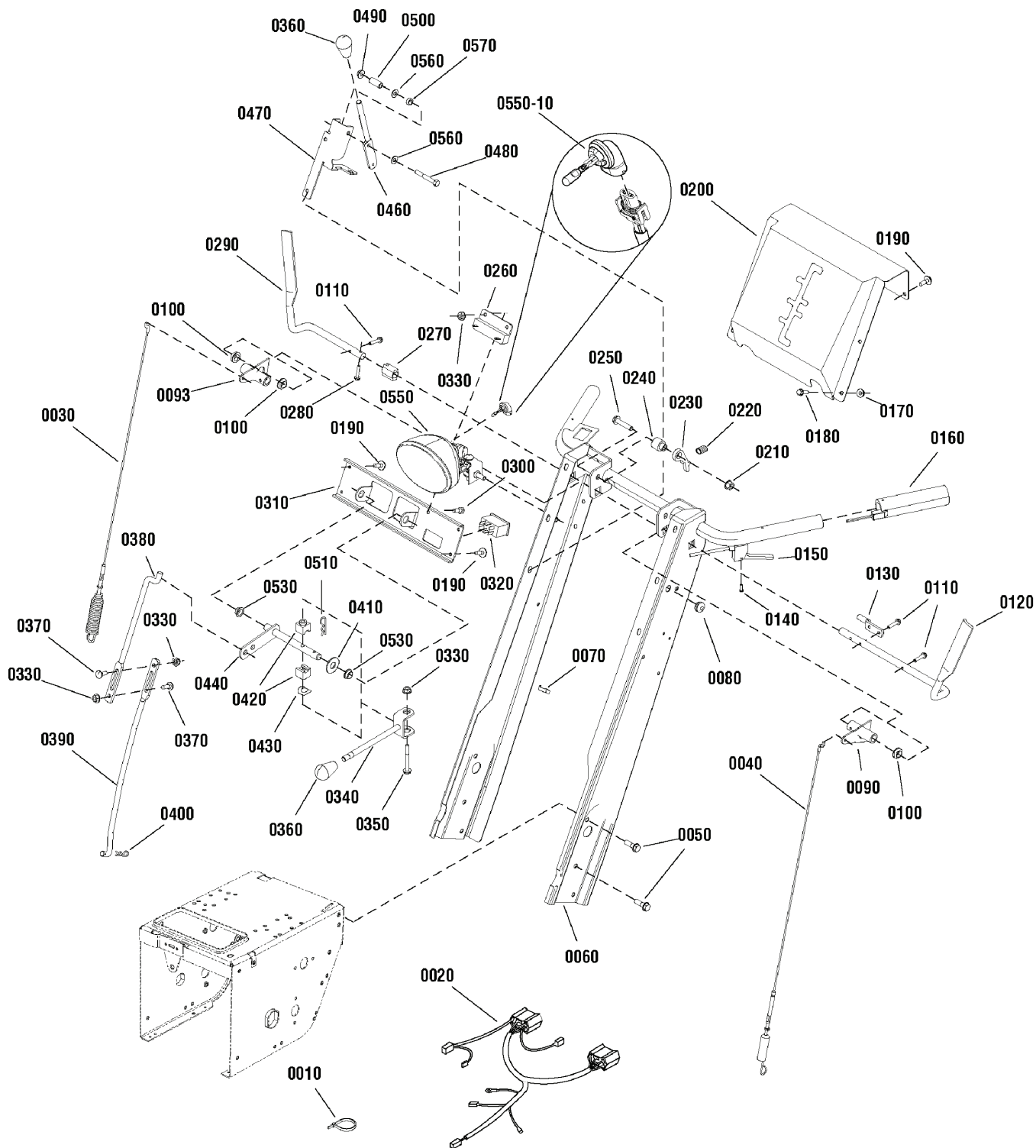

The above parts group applies to the following Mfg. Nos.:

- 1695989 - P1524E
- 1695990 - (P1728E)
- 1695991 - (P1732E)
- 1695992 - (P1738E)

Handles & Controls Group

REF NO	PART NO.	QTY.	DESCRIPTION
0440	1734696	1	PIVOT ASSEMBLY
0460	1735290	1	ROD, Chute, Deflector
0470	1734385A	1	BRACKET, Deflector Handle
0480	1921963	1	CAPSCREW, Hex Flange Head, 1/4-20 x 2
0490	1960694	1	NUT, Hex Flange, ESNA, 1/4-20
0500	1734709	1	SPRING, Compression
0510	1960074	1	CLIP, Hair Pin
0530	1668185	2	BUSHING, 1/2 ID x 3/4 OD x 1/4
0550	1737965	1	HEADLIGHT ASSEMBLY
0550-10	-----	1	* BULB, Headlight, Halogen, 881-12V 27W (Included with Ref. No. 0550)
0560	1921319	2	WASHER, 1/4
0570	1666697	1	SPACER, 5/16 ID x 1/2 OD x 1/4

Not for
Reproduction

Footnotes

Note* See your local hardware store for replacement bulbs.

The above parts group applies to the following Mfg. Nos.:

1695989 - P1524E
1695990 - (P1728E)
1695991 - (P1732E)
1695992 - (P1738E)

Engine & Frame Group

REF NO	PART NO.	QTY.	DESCRIPTION
0010	21M314-0135-F1	1	* ENGINE, 14.5TP Briggs & Stratton (Domestic) (Engine Model: 21M314-0135-F1)
0010	21M314-0127-F1	1	* ENGINE, 16.5TP Briggs & Stratton (Domestic) (Engine Model: 21M314-0127-F1)
0010-10	797095	1	GUARD, Muffler, Plate (Domestic)
0010-10	796384	1	GUARD, Muffler, Cage (Export)
0010-20	699234	3	CAPSCREW, Hex Washer Head, Muffler Guard
0010-30	795027	1	CAP, Fuel
0030	1921221	3	CAPSCREW, Hex Head, 5/16-18 x 1-1/2
0060	1739305	5	NUT, Hex Flange,ESNA, 5/16-18 (24" Models Only)
0060	2831277	5	NUT, Hex Flange, Whiz Lock, 5/16-18 (28", 32" & 38" Models Only)
0070	2822127	1	CAPSCREW, Hex Head, 5/16-18 x 1-3/4, G5
0100	1726864	1	PULLEY, Drive
0130	1726863	1	PULLEY, Engine
0140	1685366	1	WICK, Oil
0150	1726868	1	PULLEY HALF, Inside
0155	1726869	1	PULLEY, Engine
0160	1701818	1	WASHER, Thrust
0180	1922128	1	CAPSCREW, Hex Head, 3/8-24 x 1-1/2
0190	1922755	1	WASHER, 3/8
0200	1916965	1	LOCKWASHER, Spring
0230	1701849	1	SPRING, Compression
0240	1702425	1	SPRING, Compression
0290	1731178	2	STOP, Belt
0300	1921515	2	CAPSCREW, Hex Head, 5/16-24 x 3/4
0320	1917356	2	LOCKWASHER, Spring
0340	1732249	1	V-BELT, Auger, HA, 41.78
0350	1672732	1	V-BELT, Drive, 3L, 31.0
0360	1726348	1	PULLEY, Idler
0380	2860709	1	CAPSCREW, Hex Flange, Whiz Lock, 3/8-16 x 1-3/4
0400	1928352	1	NUT, Hex Flange, Whiz Lock, 3/8-16
0420	1668477	1	PULLEY, Idler
0430	1960647	1	CAPSCREW, Hex Head, 3/8-16 x 1-1/2
0460	7091575	2	NUT, Center Lock, 5/16-18
0470	1919326	6	WASHER, 5/16
0490	2159106	1	SPRING, Extension
0510	1703046BM	1	ARM, Idler
0520	1665994	1	PIN, Flat Head Drilled, 1-3/4
0530	1722460	2	PIN, Quick
0540	1727149	1	SPRING, Extension
0560	1930591	3	CAPSCREW, Hex Flange, Whiz Lock, 5/16-18 x 3/4
0570	1930595	2	CAPSCREW, Hex Flange, Whiz Lock, 5/16-18 x 1-1/4
0580	1927557	4	NUT, Hex Flange, Whiz Lock, 5/16-18
0600	1726870C	1	COVER, Bottom
0610	1925003	2	CAPSCREW, Hex Washer Head, Taptite, 1/4-20 x 1/2
0630	1725287	1	COVER, Belt

Footnotes

Note: * See your local Briggs & Stratton distributor for parts & service.

The above parts group applies to the following Mfg. Nos.:

1695989 - P1524E
 1695990 - (P1728E)
 1695991 - (P1732E)
 1695992 - (P1738E)

Engine & Frame Group

NOTE: Unless noted otherwise, use the standard hardware torque specification chart.

2988984

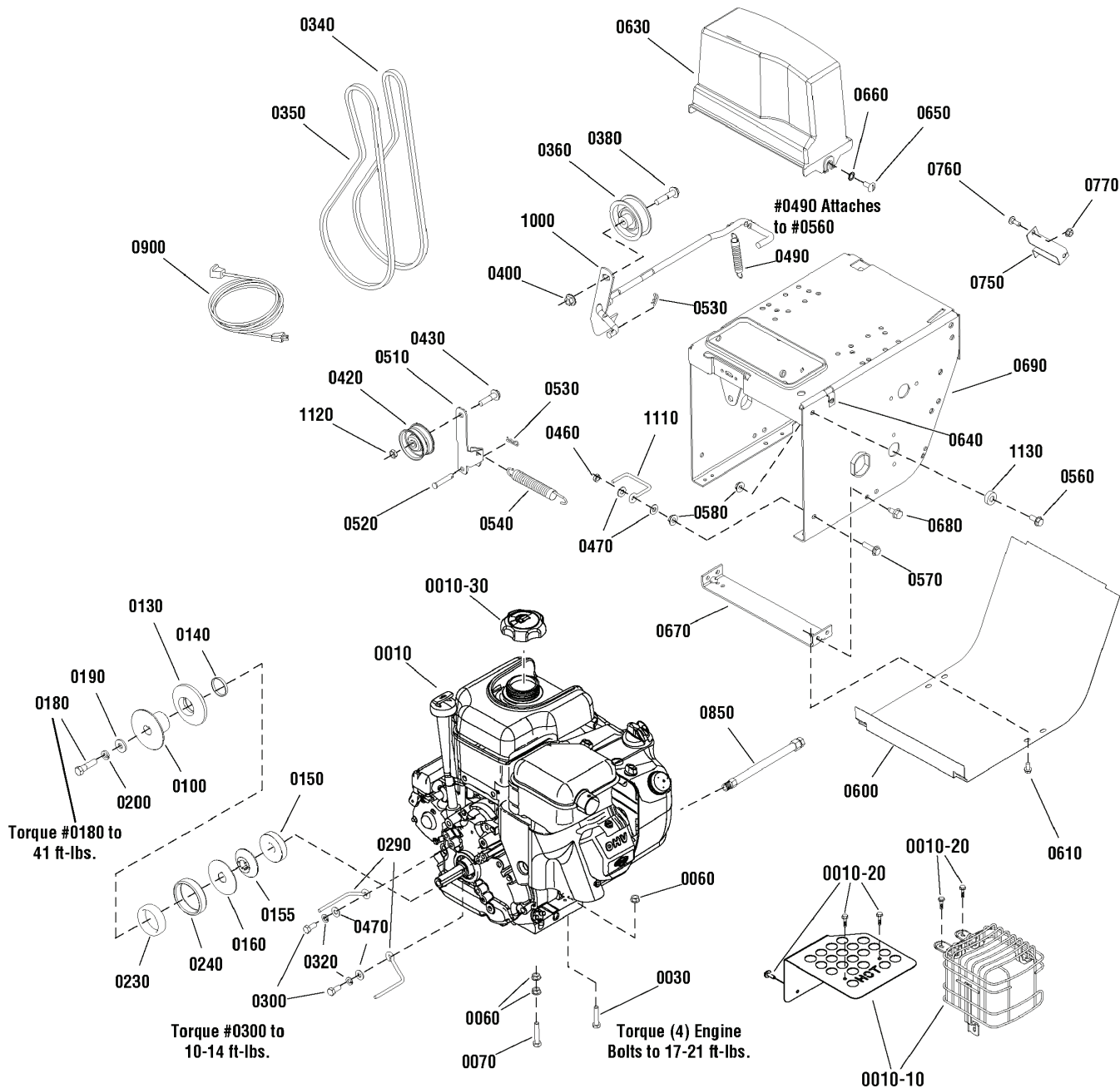

The above parts group applies to the following Mfg. Nos.:

- 1695989 - P1524E
- 1695990 - (P1728E)
- 1695991 - (P1732E)
- 1695992 - (P1738E)

Engine & Frame Group

REF NO	PART NO.	QTY.	DESCRIPTION
0640	1935255	2	NUT, Speed, 5/16-18
0650	1918249	2	SCREW, Truss Head, Slotted, 5/16-18 x 3/4
0660	2820426	2	WASHER, Lock, External Tooth, 5/16
0670	1727004BM	1	SUPPORT, Tie Bar
0680	1664847	4	CAPSCREW, Hex Washer Head, Taptite, 5/16-18 x 3/4
0690	1726568C	1	FRAME
0750	1720404BM	1	SUPPORT, Clutch Cable
0760	1931317	2	BOLT, Carriage, 1/4-20 x 3/4
0770	1960685	2	NUT, Hex Keps, 1/4-20
0850	798980	1	OIL DRAIN ASSEMBLY
0900	724865	1	CORD, Electrical (Domestic Only)
1000	1729646BM	1	CLUTCH ROD / BRAKE ARM
1110	1702969	2	STOP, Belt
1120	1928731	1	NUT, Hex, Toplock Jam, 3/8-16
1130	1666697	1	SPACER

Not for
Reproduction

Footnotes

Note: * See your local Briggs & Stratton distributor for parts & service.

The above parts group applies to the following Mfg. Nos.:

1695989 - P1524E
1695990 - (P1728E)
1695991 - (P1732E)
1695992 - (P1738E)

Auger Drive Group - Heavy Duty

2988281

NOTE: Unless noted otherwise,
use the standard hardware torque
specification chart.

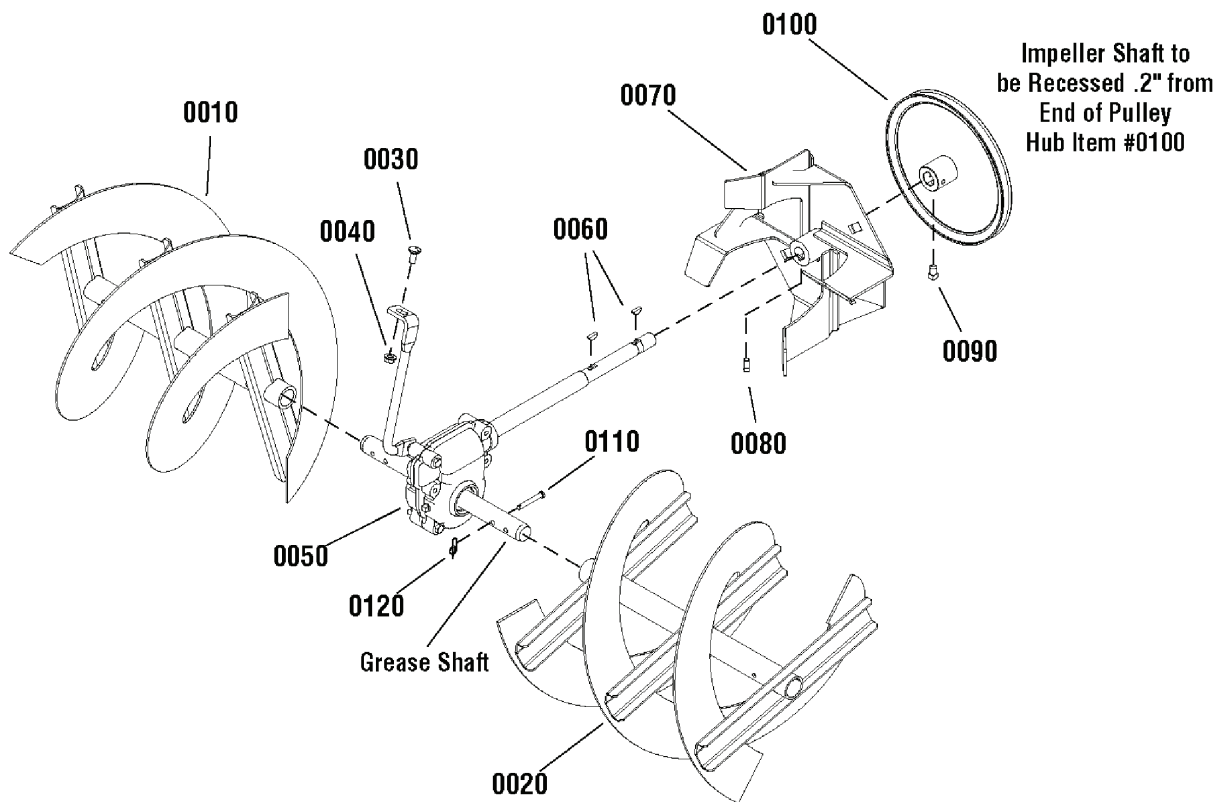

The above parts group applies to the following Mfg. Nos.:

- 1695989 - P1524E
- 1695990 - (P1728E)
- 1695991 - (P1732E)
- 1695992 - (P1738E)

Auger Drive Group - Heavy Duty

REF NO	PART NO.	QTY.	DESCRIPTION
0010	1734674A	1	AUGER ASSEMBLY, 24", R.H.
0010	1734676A	1	AUGER ASSEMBLY, 28", R.H.
0010	1734678A	1	AUGER ASSEMBLY, 32", R.H.
0010	1734680A	1	AUGER ASSEMBLY, 38", R.H.
0020	1734673A	1	AUGER ASSEMBLY, 24", L.H.
0020	1734675A	1	AUGER ASSEMBLY, 28", L.H.
0020	1734677A	1	AUGER ASSEMBLY, 32", L.H.
0020	1734679A	1	AUGER ASSEMBLY, 38", L.H.
0030	1931333	1	BOLT, Carriage, 5/16-18 x 3/4, G5
0040	1931277	1	NUT, Hex Flange, Whiz Lock, 5/16-18
0050	1732303	1	GEAR CASE ASSEMBLY, Heavy Duty
0060	2818312	2	KEY, Woodruff
0070	1612187A	1	IMPELLER
0080	1960474	1	SCREW, Set, 3/8-16 x 1/2, G8
0090	1928721	2	SCREW, Set, 5/16-18 x 1/2, G8
0100	1732468	1	PULLEY, 9 OD x 3/4 ID
0110	1668344	2	PIN, Shear, 1-3/4
0120	7023590	2	PIN, Cotter, 1/4

Not for
Reproduction

Footnotes

The above parts group applies to the following Mfg. Nos.:

1695989 - P1524E
1695990 - (P1728E)
1695991 - (P1732E)
1695992 - (P1738E)

Auger Housing Group

2988288

NOTE: Unless noted otherwise,
use the standard hardware torque
specification chart.

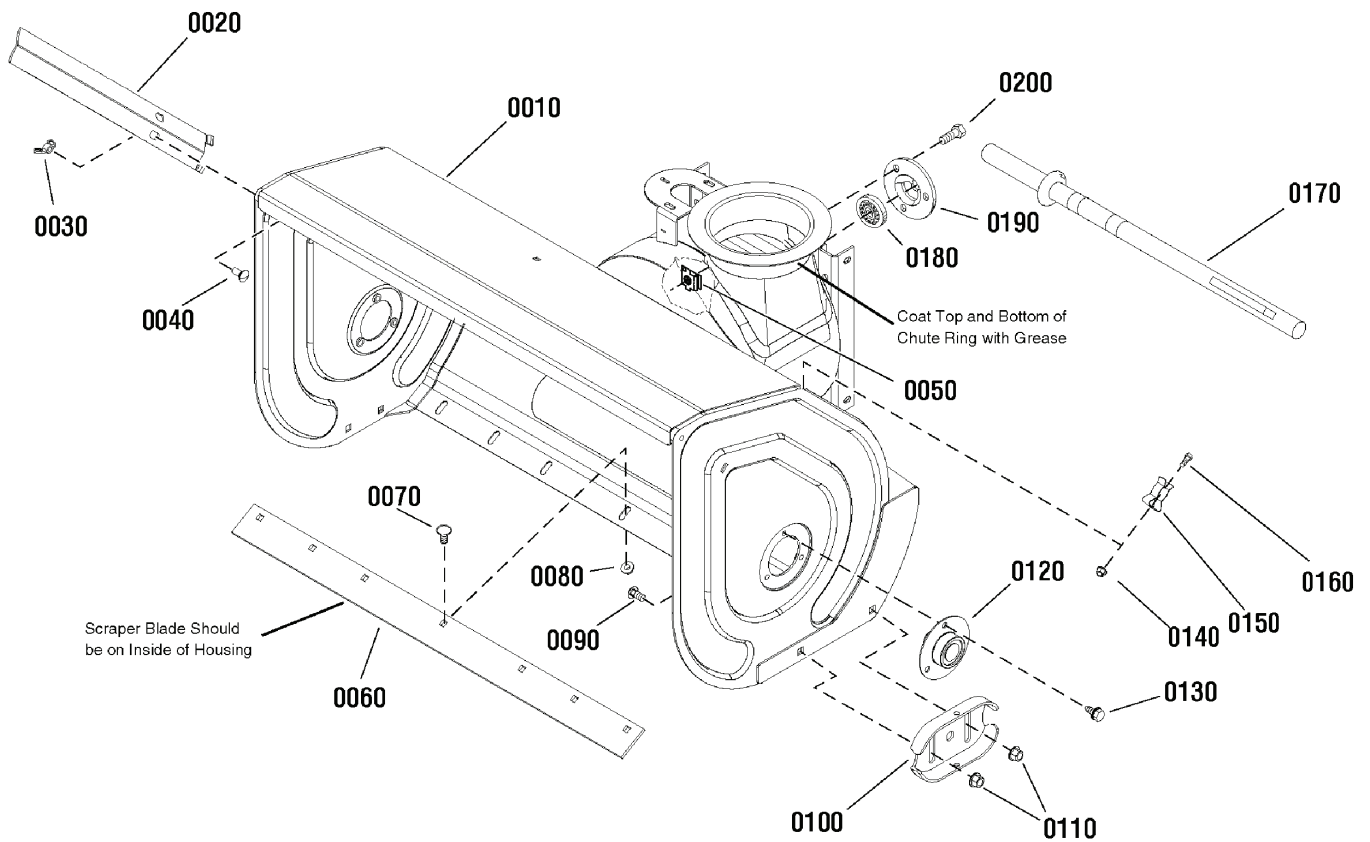

The above parts group applies to the following Mfg. Nos.:

- 1695989 - P1524E
- 1695990 - (P1728E)
- 1695991 - (P1732E)
- 1695992 - (P1738E)

Auger Housing Group

REF NO	PART NO.	QTY.	DESCRIPTION
0010	1737694C	1	AUGER HOUSING ASSEMBLY, 24"
0010	1737696C	1	AUGER HOUSING ASSEMBLY, 28"
0010	1737698C	1	AUGER HOUSING ASSEMBLY, 32"
0010	1737700C	1	AUGER HOUSING ASSEMBLY, 38"
0020	1733102BM	2	DRIFT CUTTER
0030	720125	2	NUT, Wing, Serrated, 5/16-18
0040	723873	2	BOLT, Carriage, 5/16-18 x 3/4
0050	1930659	3	NUT, Retainer, 5/16-18
0060	1709946A	1	BLADE, Scraper, 24"
0060	1709947A	1	BLADE, Scraper, 28"
0060	1709948A	1	BLADE, Scraper, 32"
0060	1723921A	1	BLADE, Scraper, 38"
0070	723873	5	BOLT, Carriage, 5/16-18 x 3/4, G5
0080	1935048	5	NUT, Hex Flange, Two Way Lock, 5/16-18
0090	1960711	4	BOLT, Carriage, 3/8-16 x 3/4, G5 (24", 28" & 32" Housing Only)
0090	1960702	4	BOLT, Carriage, 3/8-16 x 1, G5 (38" Housing Only)
0100	1727854BM	2	SHOE, Skid, Reversible (24", 28" & 32" Housing Only)
0100	1725747BM	2	SHOE, Skid (38" Housing Only)
0110	1960687	4	NUT, Hex Flange, ESNA, 3/8-16
0120	1734645	2	BEARING, Ball
0130	1664847	6	CAPSCREW, Hex Washer Head, Taptite, 5/16-18 x 3/4
0140	722401	2	NUT, Nylock, 10 x 24
0150	1736620	2	CLAMP, Retainer
0160	1960569	2	SCREW, Truss Head Torx, #10-24 x 3/8
0170	1736094	1	BRUSH, Cleanout
0180	2108202	1	BEARING, Ball
0190	1665982	1	RETAINER, Ball Bearing
0200	1960738	3	CAPSCREW, Hex Flange, Whiz Lock, 5/16-18 x 3/4

Footnotes

The above parts group applies to the following Mfg. Nos.:

1695989 - (P1524E)

1695990 - (P1728E)

1695991 - (P1732E)

1695992 - (P1738E)

Traction Drive Group

NOTE: Unless noted otherwise, use the standard hardware torque specification chart.

988280

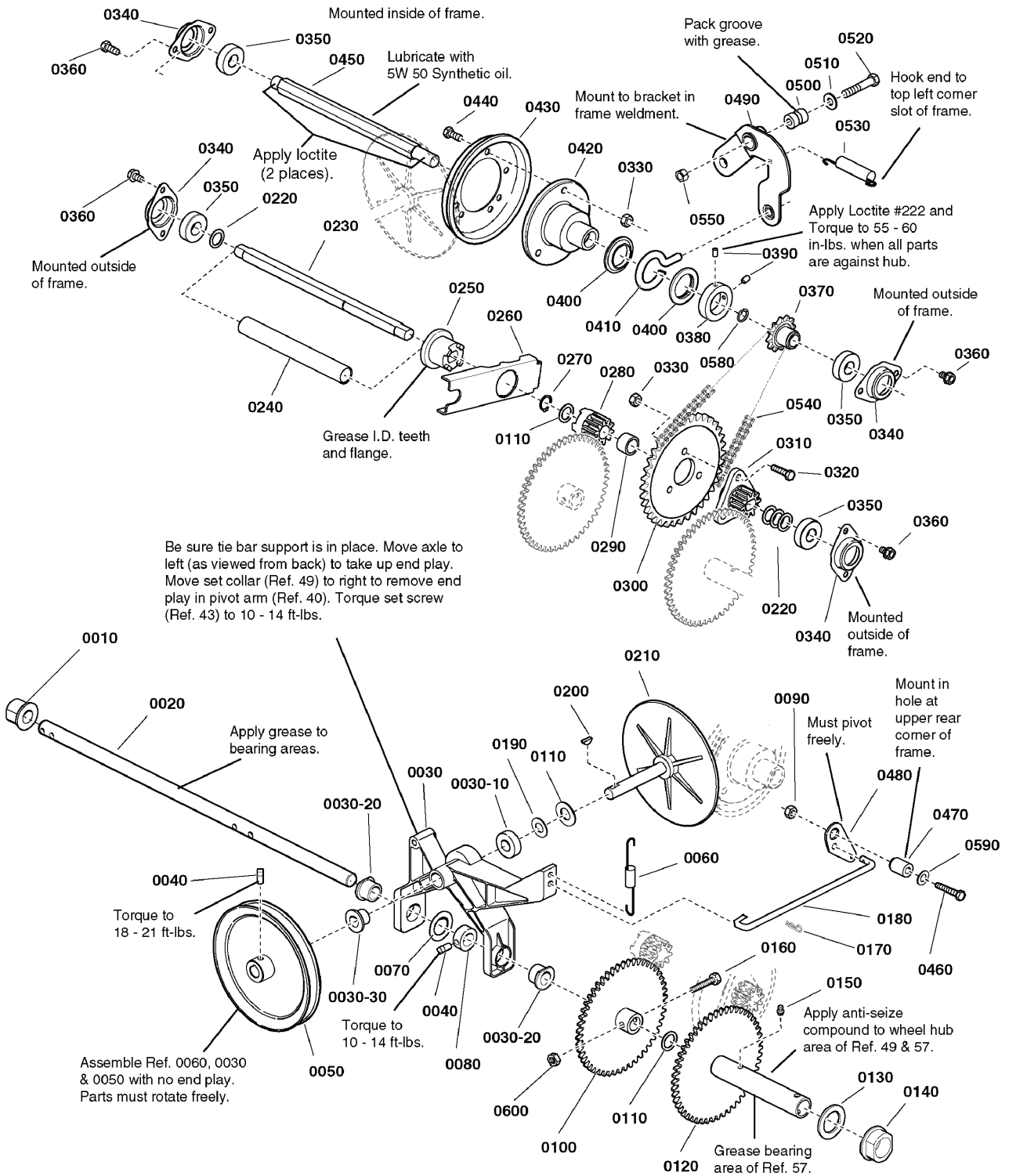

The above parts group applies to the following Mfg. Nos.:

- 1695989 - P1524E
- 1695990 - (P1728E)
- 1695991 - (P1732E)
- 1695992 - (P1738E)

Traction Drive Group

REF NO	PART NO.	QTY.	DESCRIPTION
0010	1666001	1	BUSHING, 1 Long
0020	1736641	1	AXLE, 22-13/16 Long
0030	1670849	1	ARM & PIVOT ASSEMBLY
0030-10	1665521	1	BEARING
0030-20	1666425	2	BUSHING, Flange
0030-30	1666855	1	BUSHING
0040	1928721	2	SCREW, Set, 5/16-18 x 1/2, G8
0050	1672595	1	PULLEY ASSEMBLY
0060	1725666	1	SPRING, Extension, 1/2 OD
0070	1919394	1	WASHER, 1-1/32 X 1-5/8 OD
0080	1729254	1	COLLAR, Set, 1/4 X 1-1/4 x 1/2
0090	1960686	1	NUT, Hex-Flange, 5/16-18
0100	1736639	1	GEAR ASSEMBLY
0110	1960114	3	WASHER, 3/4
0120	1730228	1	GEAR & HUB ASSEMBLY
0130	2860169	1	WASHER, 3/16
0140	1720305	1	BUSHING, 5/32
0150	7076998	1	Fitting, Lube, Straight, 1/4-28
0160	51374	2	CAPSCREW, Hex-Head, 1/4-20 x 1-1/2
0170	1722460	1	PIN, Quick, 1-3/16 Lg
0180	1726467	1	ROD, 9-1/2 Lg
0190	1924366	1	WASHER, 5/8
0200	2818312	1	KEY, Woodruff, 3/16 x 5/8, #61
0210	1719879	1	DISC, Drive, w/ Spindle
0220	2860164	4	WASHER, 5/8
0230	1718752	1	JACKSHAFT
0240	1720298	1	SPRING, Compression
0250	1718689	1	CLUTCH, Sliding, 1-1/2 OD
0260	1720078A	1	ARM, Clutch
0270	2827732	1	RING, Retaining, # 74, 3/4 Dia.
0280	1718688	1	GEAR, Stationary Clut
0290	1679556	1	SPACER, 1 Lg
0300	1667330	1	SPROCKET
0310	1718687	1	GEAR, 10T
0320	1921333	3	CAPSCREW, Hex-Head, 5/16-18 x 1, G5
0330	1960684	6	NUT, Hex, Conical Washer, 5/16-18
0340	1667341	4	RETAINER, Bearing
0350	1705897	4	BEARING, Ball, 11/16 X 1-9/16 x 15/32
0360	1930601	8	SCREW, Hex Washer-Head, 5/16-18 x 5/8
0370	1726931	1	SPROCKET, 10T
0380	1667335	1	COLLAR, 1-1/4 x 2 x 1/2
0390	1724333	2	SCREW, Set, 1/4-20 x 1/2
0400	1678956	2	COLLAR, Thrust, 1-1/4 ID x 2 OD
0410	1666207	1	PIN, LOOP 3/8 Dia. x 2-3/32 Lg

Footnotes

The above parts group applies to the following Mfg. Nos.:

1695989 - P1524E
 1695990 - (P1728E)
 1695991 - (P1732E)
 1695992 - (P1738E)

Traction Drive Group

NOTE: Unless noted otherwise, use the standard hardware torque specification chart.

988280

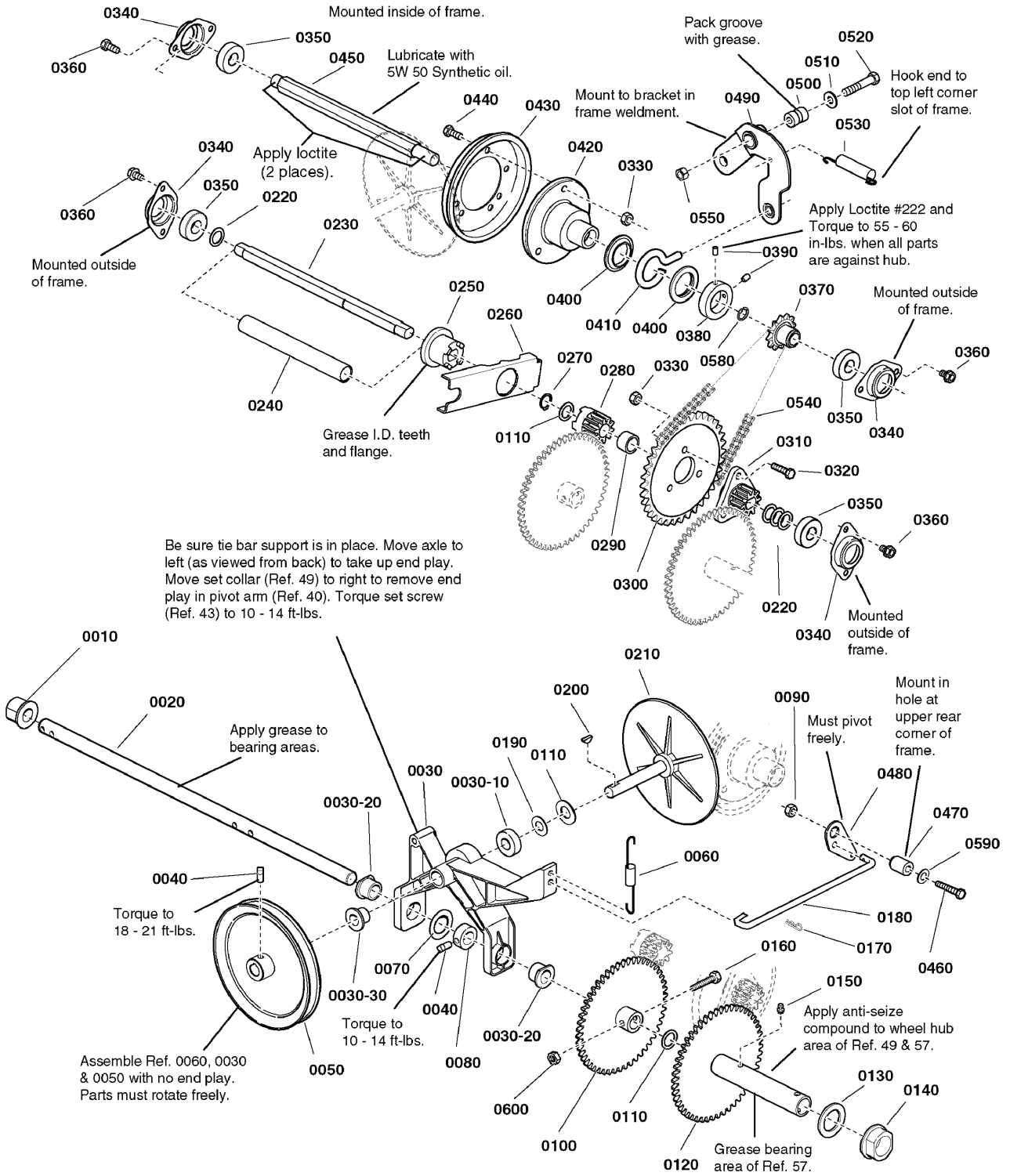

The above parts group applies to the following Mfg. Nos.:

- 1695989 - P1524E
- 1695990 - (P1728E)
- 1695991 - (P1732E)
- 1695992 - (P1738E)

Traction Drive Group

REF NO	PART NO.	QTY.	DESCRIPTION
0420	1665995	1	HUB, Friction Disc
0430	1725428	1	DISC, Friction
0440	1921332	3	CAPSCREW, Hex-Head, 5/16-18 x 3/4, G5
0450	1736100	1	SHAFT, Hex, 3/4 x 11-3/8 Lg, w/Groove
0460	1735776	1	CAPSCREW, Hex Socket-Head, 5/16-18 x 2, G8
0470	1666106	1	BUSHING, 11/32 ID x 3/4 OD, 1-1/16 Long
0480	1700473	1	BELLCRANK
0490	1669256	1	SHIFT ARM & PULLEY ASSEMBLY
0500	1666114	1	BUSHING
0510	1924940	1	WASHER, 3/8
0520	1923701	1	CAPSCREW, Hex-Head, 3/8-16 x 2, G5
0530	1668255	1	SPRING, Extension
0540	1666980	1	CHAIN, Roller, 22" Lg
0550	1960687	1	NUT, Hex-Flange, 3/8-16
0580	1736222	1	RING, Retaining, Split, # 79
0590	1919326	1	WASHER, 11/32 x 3/4 OD
0600	95661	2	NUT, Hex, Nylock 1/4-20

Not for
Reproduction

Footnotes

The above parts group applies to the following Mfg. Nos.:

1695989 - P1524E
1695990 - (P1728E)
1695991 - (P1732E)
1695992 - (P1738E)

Wheels & Tires Group

NOTE: Unless noted otherwise,
use the standard hardware torque
specification chart.

2988292

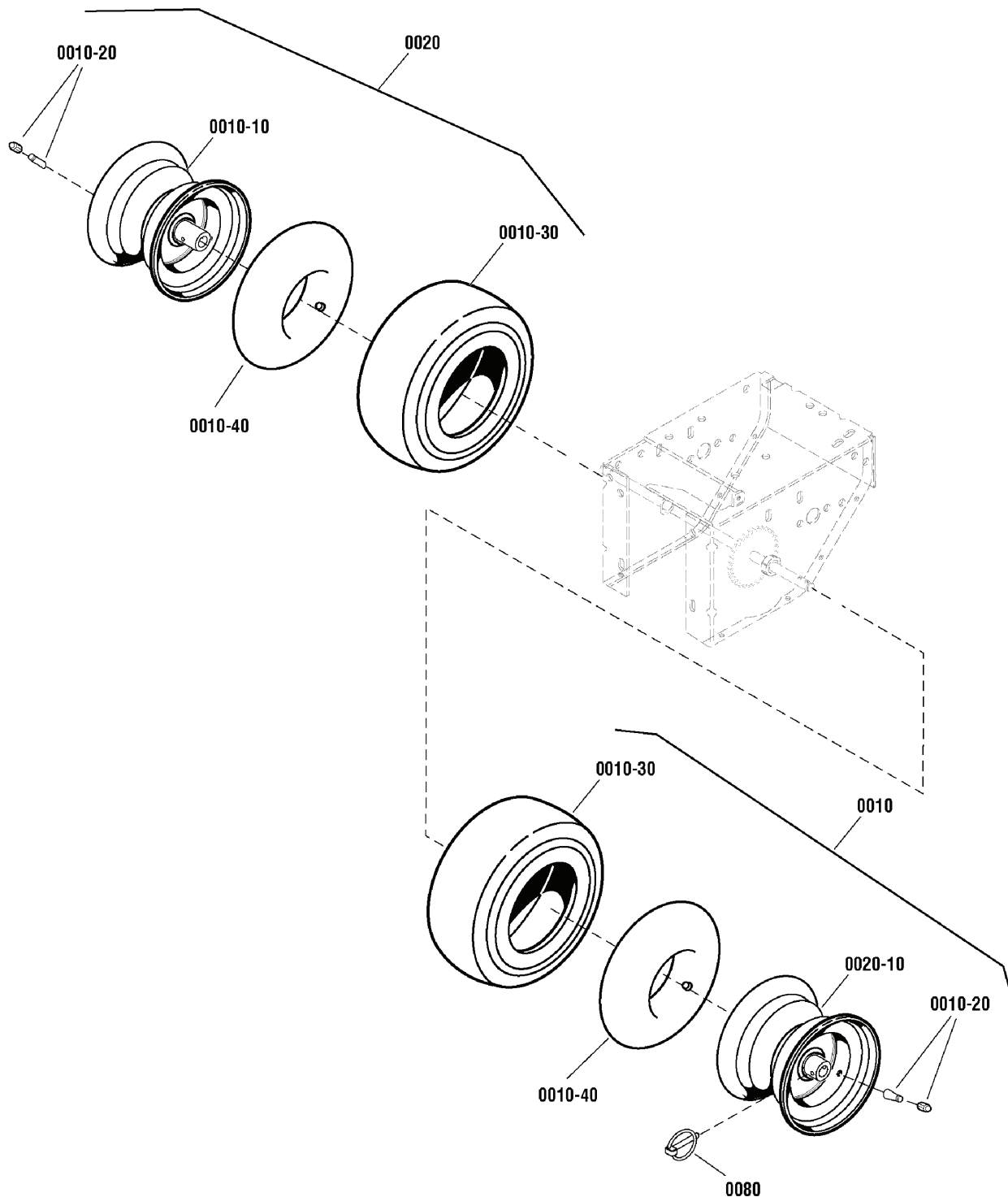

The above parts group applies to the following Mfg. Nos.:

- 1695989 - P1524E
- 1695990 - (P1728E)
- 1695991 - (P1732E)
- 1695992 - (P1738E)

Wheels & Tires Group

REF NO	PART NO.	QTY.	DESCRIPTION
0010	1751465	1	WHEEL ASSEMBLY, 16 X 4.8, A478, L.H. (24" & 28" Models Only)
0010	1726744	1	WHEEL ASSEMBLY, 16 x 6-1/2, K478, L.H. (32" & 38" Models Only) (Includes Ref. Nos. 0010-10, 0010-20, 0010-30 & 0010-40)
0010-10	-----	1	*RIM, 3.75-8, L.H. (24" & 28" Models Only)
0010-10	-----	1	*RIM, 8 x 5-3/8 x 4, L.H. (32" & 38" Models Only)
0010-20	2172353	2	VALVE STEM & CAP
0010-30	1751298	2	TIRE, 4.80 / 4.00 - 8, 2 Ply, A478 (24" & 28" Models Only)
0010-30	1727075	2	TIRE, 16 x 6-1/2 - 8, X-Track TL (32" & 38" Models Only)
0010-40	2153038	2	TUBE, Tire, 4-8 (24" & 28" Models Only)
0010-40	2164247	2	TUBE, Tire, 16 x 6-1/2 - 8 (32" & 38" Models Only)
0020	1751466	1	WHEEL ASSEMBLY, K478 4.80-8, R.H. (24" & 28" Models Only)
0020	1726745	1	WHEEL ASSEMBLY, 16 x 6-1/2, K478, R.H. (32" & 38" Models Only) (Includes Ref. Nos. 0020-10, 0010-20, 0010-30 & 0010-40)
0020-10	-----	1	*RIM, 3.75-8, R.H. (24" & 28" Models Only)
0020-10	-----	1	*RIM, 8 x 5-3/8 x 4, R.H. (32" & 38" Models Only)
0080	1731186	2	PIN, Klik, 5/16 x 2

Not for
Reproduction

Footnotes

*Not a servicable part. Order Complete Wheel & Tire Assembly

The above parts group applies to the following Mfg. Nos.:

1695989 - P1524E
1695990 - (P1728E)
1695991 - (P1732E)
1695992 - (P1738E)

Decals Group

NOTE: Unless noted otherwise, use the standard hardware torque specification chart.

2988985

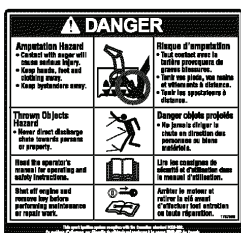
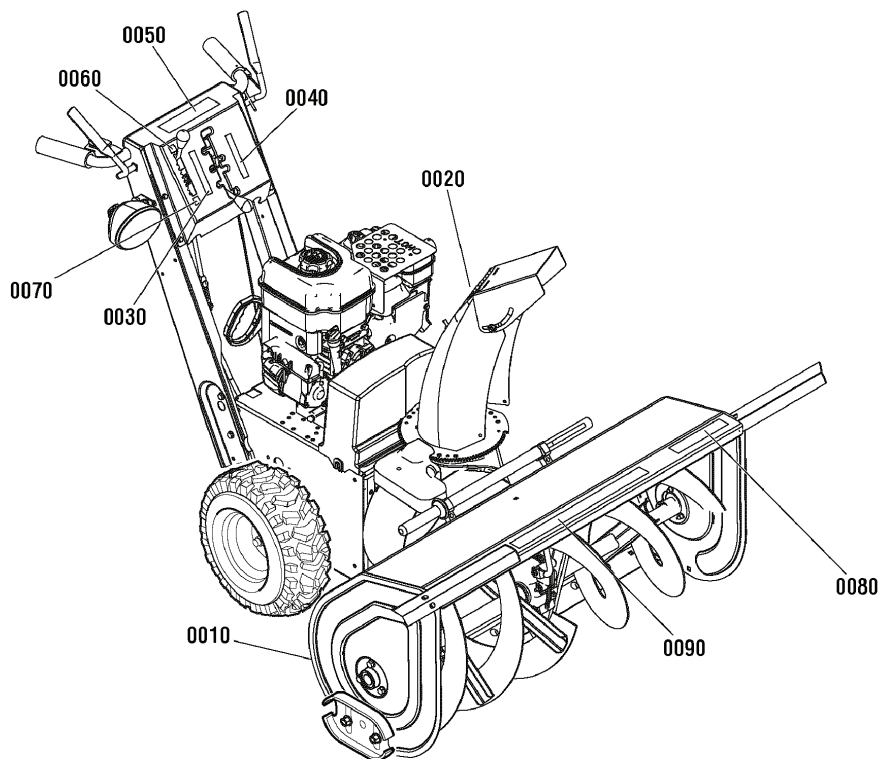

0010



0020

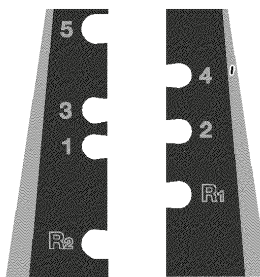

0030

0040



0080



0070



0010

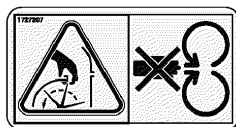

0020

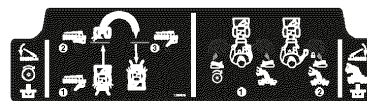

0050



0060



0090



0100

The above parts group applies to the following Mfg. Nos.:

- 1695989 - P1524E
- 1695990 - (P1728E)
- 1695991 - (P1732E)
- 1695992 - (P1738E)

Decals Group

REF NO	PART NO.	QTY.	DESCRIPTION
0010	1737866	1	DECAL, Danger Foot, FR/ENG (Domestic)
0010	1737867	1	DECAL, Danger Auger Icons (CE/ Export)
0020	1737865	1	DECAL, Danger Chute Warning, FR/ENG (Domestic)
0020	1727207	1	DECAL, Chute Warning (CE/ Export)
0030	1734786	1	DECAL, Left Shift Pattern
0040	1734787	1	DECAL, Right Shift Pattern
0050	1737873	1	DECAL, Controls
0060	1734788	1	DECAL, Deflector Up
0070	1734789	1	DECAL, Deflector Down
0080	1734733	1	DECAL, Model, 1524P
0080	1750424	1	DECAL, Model, P1728E
0080	1750710	1	DECAL, Model, P1728EX
0080	1734735	1	DECAL, Model, 1732P
0080	1750425	1	DECAL, Model, P17232E
0080	1750426	1	DECAL, Model, P1738E
0090	1733071	1	DECAL, Housing, Stripe, 24" Long
0090	1733246	1	DECAL, Housing, Stripe, 28" Long
0090	1733244	1	DECAL, Housing, Stripe, 32" Long
0090	1733074	1	DECAL, Housing, Stripe, 38" Long
0100	1725507	1	DECAL, Power Boost

Not for
Reproduction

Footnotes

The above parts group applies to the following Mfg. Nos.:

1695989 - P1524E

1695990 - (P1728E)

1695991 - (P1732E)

1695992 - (P1738E)

Chute & Rotation Group - Electric Chute/Remote Deflector

988278

NOTE: Unless noted otherwise,
use the standard hardware torque
specification chart.

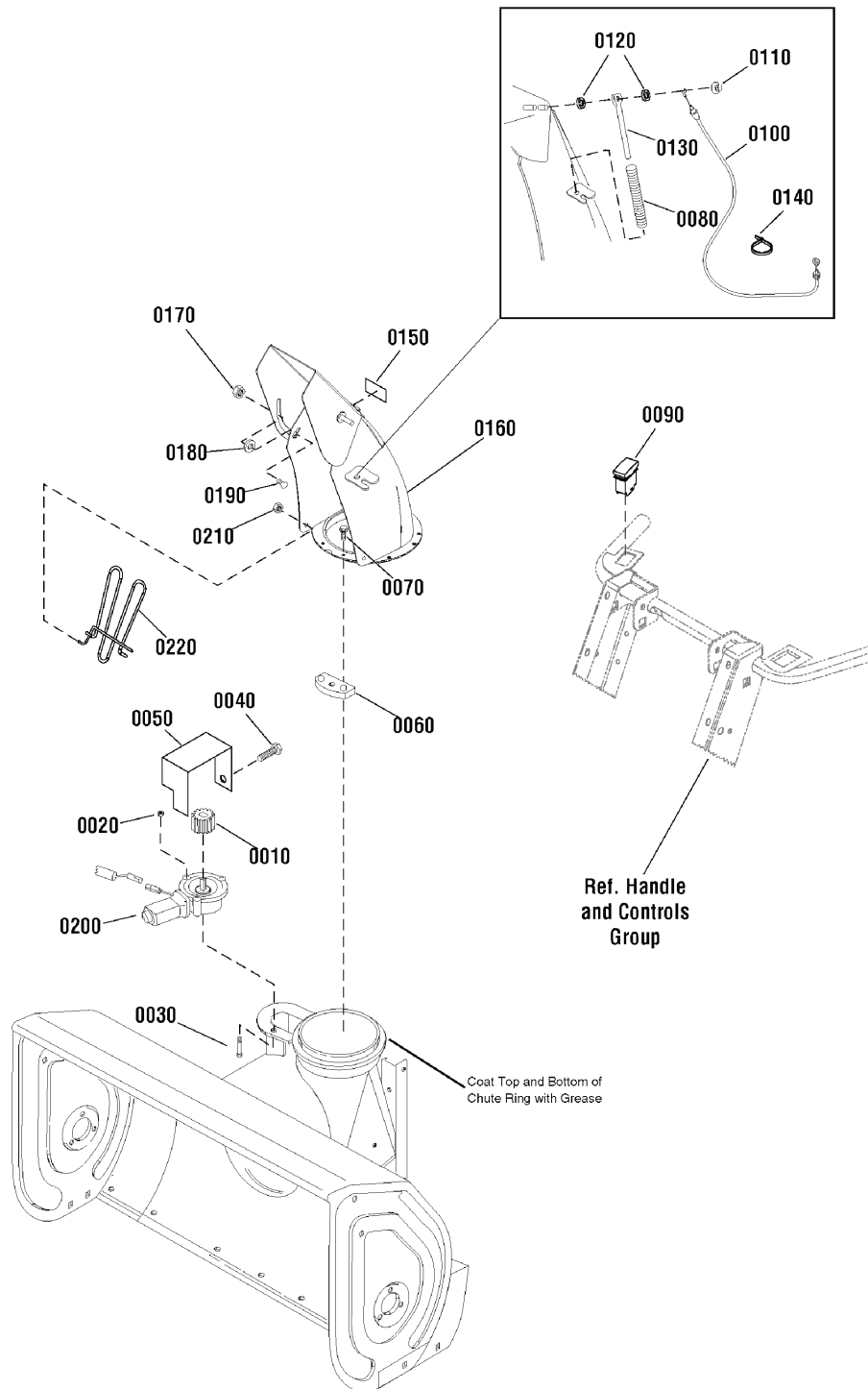

The above parts group applies to the following Mfg. Nos.:

- 1695989 - P1524E
- 1695990 - (P1728E)
- 1695991 - (P1732E)
- 1695992 - (P1738E)

Chute & Rotation Group - Electric Chute/Remote Deflector

REF NO	PART NO.	QTY.	DESCRIPTION
0010	1728967	1	PINION, 1-1/4 Lg
0020	1960745	3	NUT, Whiz Lock, #10-24
0030	2860604	3	CAPSCREW, Hex Washer, #10 x 1-1/4, G2
0040	1927428	1	CAPSCREW, Hex Washer, Self Tapping, 1/4-20 x 3/8
0050	1733934A	1	COVER, Gear
0060	1666613	3	RETAINER, Chute
0070	1960001	3	CAPSCREW, Hex Washer, 10-14 x 5/8
0080	1734647	1	SPRING, Compression, 9/16 OD x 6-1/16 Lg
0090	1728969	1	SWITCH, Rocker, Chute Rotation, 5-Pin
0100	1732971	1	CABLE, Deflector Control
0110	1932718	1	PUSHNUT, 5/16 Dia. x 5/8 OD
0120	1666697	2	SPACER, 1/2 OD x 7/32 Lg
0130	1734708A	1	ROD, 5/16 Dia., 5-7/8 Lg
0140	1701011	1	TIE, Self Locking, 7-5/16 Lg
0150	1706085	2	DECAL, Hinge (24", 28" & 32" Models Only)
0150	1733598	2	DECAL, Hinge (38" Models Only)
0160	1734400C	1	CHUTE ASSEMBLY, 32" (24", 28" & 32" Models Only)
0160	1736419C	1	CHUTE ASSEMBLY, 38" (38" Models Only)
0170	1960686	1	NUT, Hex Flange, 5/16-18
0180	2860210	1	WASHER, Nylon, 3/8
0190	1931333	1	BOLT, Carriage, 5/16-18 x 3/4, G5
0200	1728965	1	MOTOR, Spout Rotator, 38"
0210	1960126	2	PUSHNUT, 1/4 Dia. (CE/Export Only)
0220	1735174	1	GUARD & SUPPORT ASSEMBLY (CE/Export Only)

Not for
Reproduction

Footnotes

The above parts group applies to the following Mfg. Nos.:

1695989 - P1524E

1695990 - (P1728E)

1695991 - (P1732E)

1695992 - (P1738E)

Gear Case Assembly - Heavy Duty

NOTE: Unless noted otherwise, use the standard hardware torque specification chart.

1732303

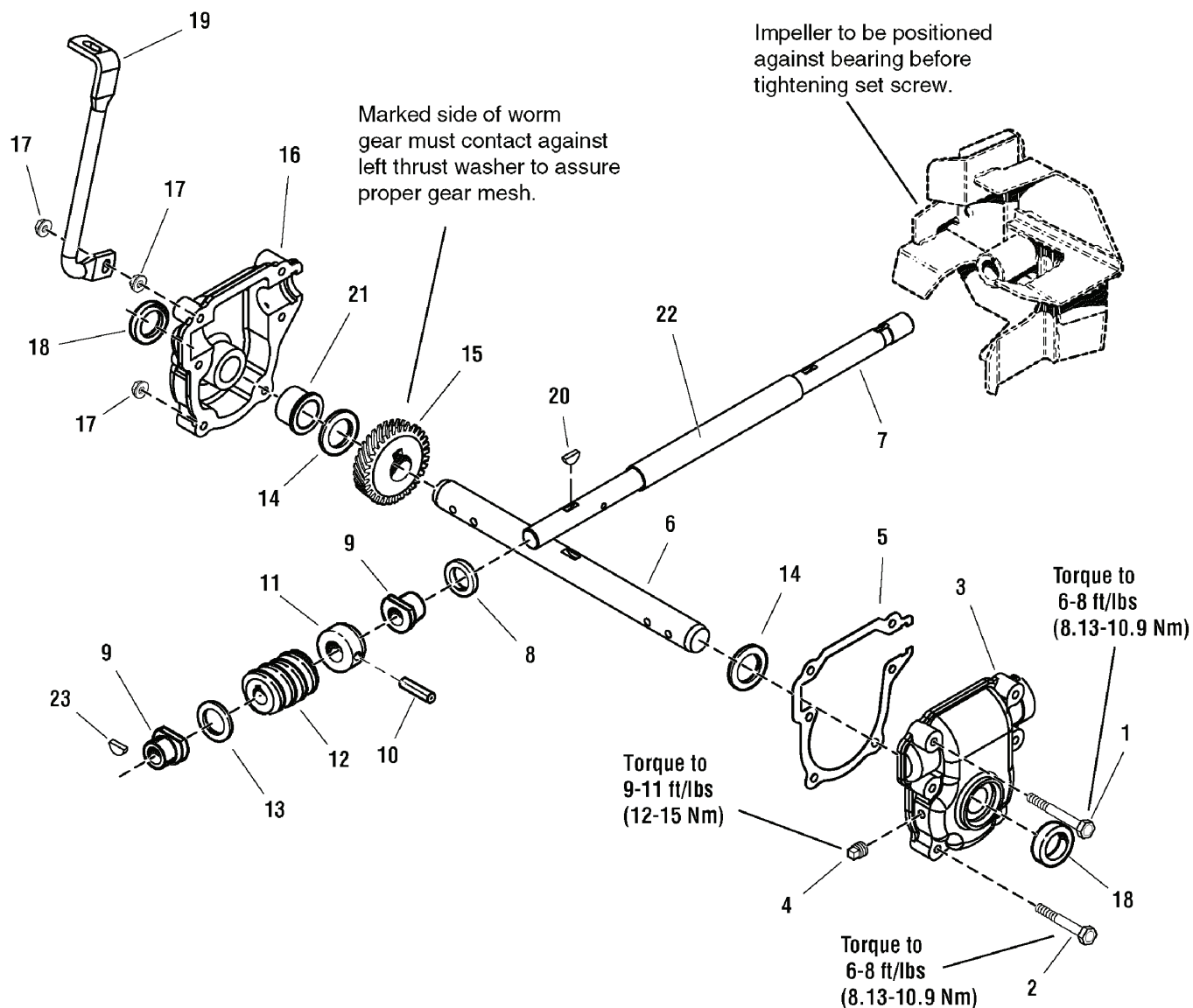

The above parts group applies to the following Mfg. Nos.:

- 1695989 - P1524E
- 1695990 - (P1728E)
- 1695991 - (P1732E)
- 1695992 - (P1738E)

Gear Case Assembly - Heavy Duty

REF NO	PART NO.	QTY.	DESCRIPTION
1	1923282	1	CAPSCREW, Hex Head, 1/4-20 x 2-1/2
2	1960346	5	CAPSCREW, Hex Head, 1/4-20 x 2-1/4
3	1612136	1	GEAR CASE, L.H.
4	1668971	1	FITTING, Pipe Plug
5	1612124	1	GASKET
6	1732440	1	SHAFT, Auger Cutoff
7	1732182	1	SHAFT, Worm Cutoff
8	1612093	2	SEAL, Oil
9	1612149	2	FLANGE BUSHING
10	2836098	1	PIN, Drive Lock
11	1612127	1	THRUST COLLAR
12	1612142	1	WORMGEAR, 1-3/4 OD x 1-3/8 Long
13	2168111	1	THRUST WASHER
14	2118315	2	THRUST WASHER
15	1612141	1	WORMGEAR, 21T, 3" O.D. x 7/8 Long
16	1612137	1	GEAR CASE, R.H.
17	1930642	7	NUT, Top Lock Flange 1/4-20
18	2118118	1	SEAL
19	1732152	1	BRACKET, Support
20	2818312	1	KEY, Woodruff .18 x .62
21	1732991	2	BUSHING
22	1612111	1	TUBE
23	2830246	1	KEY, Woodruff 1/4 x 3/4

Not for
Reproduction

Footnotes

The above parts group applies to the following Mfg. Nos.:

1695989 - P1524E
1695990 - (P1728E)
1695991 - (P1732E)
1695992 - (P1738E)

Not for
Reproduction

Hardware Identification & Torque Specifications

Torque Specification Chart								
FOR STANDARD METRIC MACHINE HARDWARE (Tolerance ± 20%)								
Property Class	5.6		8.8		10.9		12.9	
	Class 5.6		Class 8.8		Class 10.9		Class 12.9	
Size Of Hardware	in/lbs	Nm.	in/lbs	Nm.	in/lbs	Nm.	in/lbs	Nm.
	ft/lbs		ft/lbs		ft/lbs		ft/lbs	
M3	5.88	.56	13.44	1.28	19.2	1.80	22.92	2.15
M4	13.44	1.28	30.72	2.90	43.44	4.10	52.56	4.95
M5	26.4	2.50	60.96	5.75	5.97	8.10	7.15	9.7
M6	44.64	4.3	7.3	9.9	10.3	14	12.1	16.5
M7	5.2	7.1	12.1	16.5	16.9	23	19.9	27
M8	7.7	10.5	17.7	24	25	34	29	40
M10	15	21	35	48	50	67	59	81
M12	26	36	61	83	86.2	117	103	140
M14	42	58	101	132	136	185	162	220
M16	64	88	147	200	210	285	250	340
M18	89	121	202	275	287	390	346	470
M20	126	171	290	390	405	550	486	660
M22	169	230	390	530	559	745	656	890
M24	217	295	497	375	708	960	840	1140
M27	320	435	733	995	1032	1400	1239	1680
M30	435	590	995	1350	1401	1900	1681	2280
M33	590	800	1349	1830	1902	2580	2278	3090
M36	759	1030	1740	2360	2441	3310	2935	3980
M39	988	1340	2249	3050	3163	4290	3798	5150

Torque Specification Chart						
FOR STANDARD MACHINE HARDWARE (Tolerance ± 20%)						
Hardware Grade	No Marks		SAE Grade 5		SAE Grade 8	
	SAE Grade 2		SAE Grade 5		SAE Grade 8	
Size Of Hardware	in/lbs	Nm.	in/lbs	Nm.	in/lbs	Nm.
	ft/lbs		ft/lbs		ft/lbs	
8-32	19	2.1	30	3.4	41	4.6
8-36	20	2.3	31	3.5	43	4.9
10-24	27	3.1	43	4.9	60	6.8
10-32	31	3.5	49	5.5	68	7.7
1/4-20	66	7.6	8	10.9	12	16.3
1/4-28	76	8.6	10	13.6	14	19.0
5/16-18	11	15.0	17	23.1	25	34.0
5/16-24	12	16.3	19	25.8	29	34.0
3/8-16	20	27.2	30	40.8	45	61.2
3/8-24	23	31.3	35	47.6	50	68.0
7/16-14	30	40.8	50	68.0	70	95.2
7/16-20	35	47.6	55	74.8	80	108.8
1/2-13	50	68.0	75	102.0	110	149.6
1/2-20	55	74.8	90	122.4	120	163.2
9/16-12	65	88.4	110	149.6	150	204.0
9/16-18	75	102.0	120	163.2	170	231.2
5/8-11	90	122.4	150	204.0	220	299.2
5/8-18	100	136	180	244.8	240	326.4
3/4-10	160	217.6	260	353.6	386	525.0
3/4-16	180	244.8	300	408.0	420	571.2
7/8-9	140	190.4	400	544.0	600	816.0
7/8-14	155	210.8	440	598.4	660	897.6
1-8	220	299.2	580	788.8	900	1,244.0
1-12	240	326.4	640	870.4	1,000	1,360.0

The guides and ruler furnished below are designed to help you select the appropriate hardware.

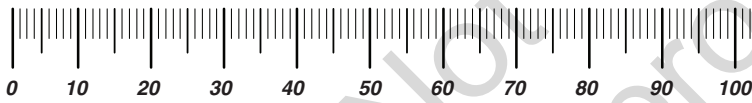

Nut, M8

Thread Diameter (mm)
Inside Diameter (in)
Threads per inch

Nut, 1/2-16

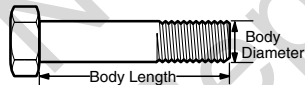

Screw, M8 - 1.25 x 25

Thread Diameter (mm)
Body Diameter
Distance between threads (mm)
Threads per inch
Body Length (mm)
Body Length (in)

Screw, 1/2- 16 x 2

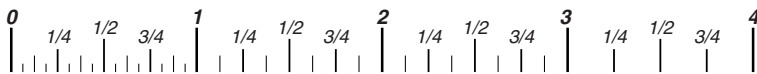

Standard Hardware Sizing

When a washer or nut is identified as **1/2"** (M8), this is the *Nominal size*, meaning the *inside diameter* is 1/2 inch (8mm metric thread diameter); if a second number is present it represents the *threads per inch* (distance between threads).

When bolt or capscrew is identified as **1/2 - 16 x 2"** (M8 - 1.25 x 50), this means the *Nominal size*, or body diameter is 1/2 inch (8mm metric thread diameter), the second number, 16, represents the *threads per inch*, (1.25 thread diameter). The final number is the body length of the bolt or screw, 2 inches (50mm).

NOTES

- These torque values are to be used for all hardware excluding: locknuts, self-tapping screws, thread forming screws, sheet metal screws and socket head setscrews.
- Recommended seating torque values for locknuts:
 - for prevailing torque locknuts - use 65% of grade 5 torques.
 - for flange whizlock nuts and screws - use 135% of grade 5 torques.
- Unless otherwise noted on assembly drawings, all torque values must meet this specification.

Common Hardware Types

Hex Head Capscrew



Washer

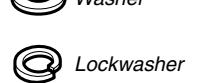

Carriage Bolt



Hex Nut

Wrench & Fastener Size Guide

1/4" Bolt or Nut Wrench—7/16"	5/16" Bolt or Nut Wrench—1/2"	3/8" Bolt or Nut Wrench—9/16"	7/16" Bolt or Nut Wrench (Bolt)—5/8" Wrench (Nut)—11/16"	1/2" Bolt or Nut Wrench—3/4"
M6 Bolt or Nut Wrench—10mm	M8 Bolt or Nut Wrench—13mm	M10 Bolt or Nut Wrench—17mm	M12 Bolt or Nut Wrench—19mm	M14 Bolt or Nut Wrench—22mm

**IT IS THE POLICY OF BRIGGS & STRATTON CORP. TO IMPROVE ITS PRODUCTS
WHENEVER IT IS POSSIBLE AND PRACTICAL TO DO SO. WE RESERVE THE RIGHT TO
MAKE CHANGES OR ADD IMPROVEMENTS AT ANY TIME WITHOUT INCURRING ANY
OBLIGATION TO MAKE SUCH CHANGES ON PRODUCTS.**

Briggs & Stratton Yard Power Products Group

3515 N. 124 Street / PO Box 702
Wauwatosa, WI 53222 USA

www.simplicitymfg.com

© Copyright 2011 by Briggs & Stratton Corporation
Milwaukee, WI, USA. All rights reserved