

# SPEAKMAN EYESAVER® LABORATORY FAUCETS

## LABORATORY FAUCET WITH INTEGRATED EYEWASH SEF-2001

SPECIFICATION

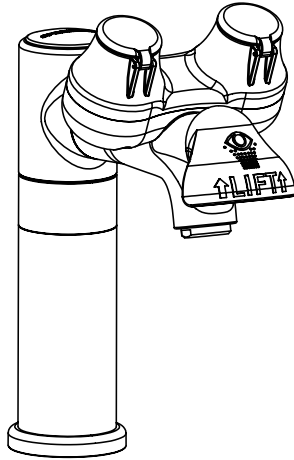

The Speakman SEF-2001 is a NSF 61 compliant laboratory faucet with an integrated ANSI compliant aerated eyewash. Dedicated water ways allow the faucet and eyewash to work independently of each other.

### EYEWASH FEATURES:

- Lift handle activator
- Dedicated water channel for eyewash
- Aerated plated spray outlets with flip-top dust covers
- 2 gpm (7.57 L/min) flow rate at 30 PSI
- Tepid water ready

### FAUCET FEATURES:

- Lead-free brass construction
- Swivel or rigid spout up to 100 degrees
- 1.5 gpm (5.7 L/min) flow rate

### COMPLIANCE:

- Certified to ANSI Z358.1, ASME A112.18.1/CSA B125.1, NSF 61 & CA AB 1953

### AVAILABLE FINISHES:

ADD SUFFIX TO MODEL #

- Polished Chrome (standard)

### OPTIONS:

- 8 In. spout  -8
- Serrated tip with vacuum breaker  -ST (not available in lead free option)
- Non-aerated eyewash and laminar faucet flow control 1.5 gpm (6.68 L/min)  -NA
- Thermostatic mixing valve  -TW
- 6" wrist blade handles  -6WH

### WARRANTY:

- 25 YEARS FOR CERAMIC CARTRIDGES
- 1 YEAR LIMITED

SEF-2001 SIDE VIEW (LESS HOSES)

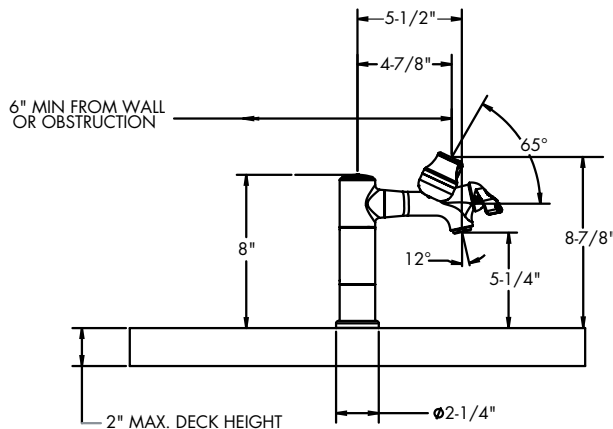

PATENT PENDING

NOTE: 1. All dimensions are in inches (millimeters) unless otherwise specified and are subject to change without notice. Unless otherwise specified, all inlets are 3/8" compression with female threads

THIS SPACE FOR ARCHITECT/ENGINEER APPROVAL.

# SPEAKMAN®

400 ANCHOR MILL ROAD | NEW CASTLE, DE 19720  
 P: 800-537-2107 | F: 800-977-2747  
 WWW.SPEAKMANCOMPANY.COM



REVISION DATE: JUNE 2013