

Contents

Product Specifications.....	2	ZWave Install.....	16
Operation.....	3	Inclusion.....	16
Thermostat Control Screen Function Control		Exclusion.....	16
Buttons.....	4	Inclusion and Exclusion	16
Minimized Display Mode	5	Thermostat Info	17
Menu Map	6	Installer Settings.....	18
User Settings	7	System Settings.....	19
Set Clock	7	Thermostat Recovery Operation.....	19
Filter Service	8	Mechanical Settings	20
Maint Service.....	9	Fan Cyclor Settings.....	20
Screen Timeout.....	10	Schedules.....	21
F/C Settings	11	Installation.....	24
Sensor Calibration.....	12	Warranty	25
Backlite/Display.....	13	Index	26
Usage Graph	14		
ESM Setpoints	15		

Product Specifications

Specification	Description
Product Model:	TZEMT400BB32MAA
Product:	Thermostat for Heating and Cooling HVAC System control. Z-Wave™ RF communications enabled
Thermostat	
Size:	5.7" wide x 4.0" height x 1.2" depth
Display:	Graphical LCD, 2.75" x 1.5", 64x128-pixel
Backlight:	Yes, Blue/white, Controllable, on, off, timeout
Contrast:	Adjustable on screen
Buttons:	6
Power:	24VAC from HVAC System
HVAC System Type Compatible:	Standard (gas/electric) or Heat Pump
Multistage System Compatible:	Standard HVAC Systems: 2 stage heating, 2-stage cooling Heat Pump Systems: 3 stage heating (2-compressor, 1 aux heat), 2-stage cooling
Heat Pump change over valve:	Selectable change over with cool or with heat
Communications:	Z-Wave™ RF

Operation

The model TZEMT400BB32MAA thermostat provides typical thermostat control of a central heating and cooling HVAC system. This thermostat also features a Z-Wave™ module for remote control.

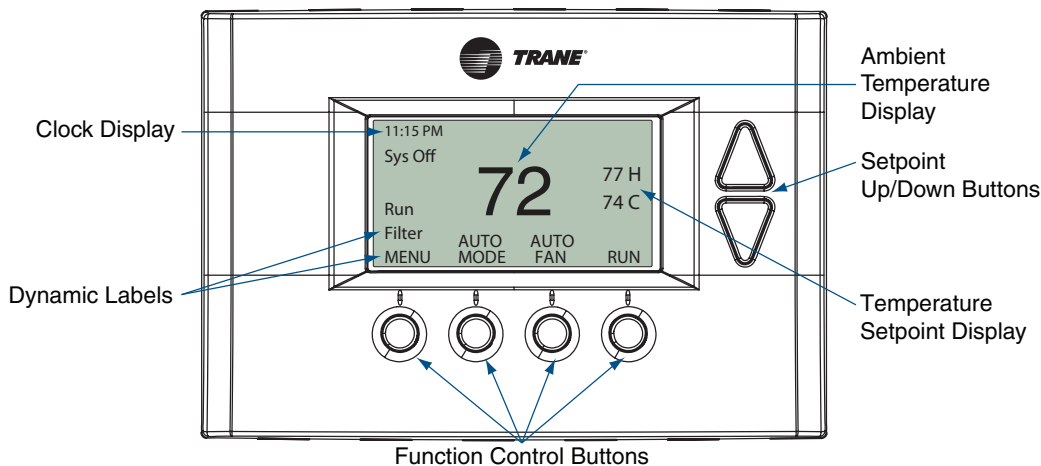

Normally, the thermostat displays the thermostat control screen as shown above.

Item	Description	Notes
Clock Display	The current time is displayed in the upper left corner of the main screen. The time will blink when the clock has not been set.	See "User Settings", Set Clock for instructions to set time, date, and day.
Function Control Buttons and Dynamic Labels	As you press the function buttons and navigate through menus, the button labels will change. Dynamic button labels are displayed above or beside each button.	
Setpoint Display and Setpoint Up/Down Buttons	The current heat and cool temperature setpoints are displayed. These setpoints may be set using the Z-Wave control system, by pressing the Setpoint Up/Down buttons, or through the thermostat's internal schedule Note: If the system mode is set to HEAT the setpoint Up/Down buttons change the heat setpoint. If the system mode is set to COOL the setpoint Up/Down buttons change the cool setpoint. In AUTO mode, the buttons change the heating or cooling setpoint of the last active mode.	The setpoints will push each other if they are adjusted to within the minimum heat/cool separation setting. This is normally 3 degrees. The internal schedule is disabled by default. See system setting H/C Delta for more information.
Temperature Display	The thermostat displays the ambient temperature as sensed by the internal temperature sensor.	The internal temperature sensor can be calibrated. See the Sensor Calibration section.

Thermostat Function Control Buttons

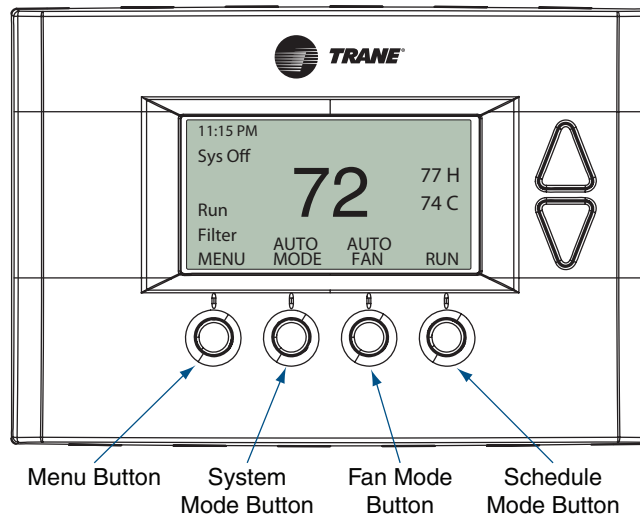

Button	Description
Menu	Other thermostat menus can be accessed by pressing the MENU button.
System Mode	Used to <u>change</u> the system mode Off: System off Heating: Heating only on Cooling: Cooling only on Auto: Heating/Cooling on as necessary
Fan Mode	Used to <u>change</u> the fan mode Auto: Fan on when cooling/heating is necessary On: Fan constantly on
Schedule Mode	Used to <u>change</u> the schedule mode Hold: System maintains the current temperature setpoints. Schedules are disregarded. Run: Run the system schedule (or Z-Wave controlled schedule) Energy Saving Mode: Temperature setpoints in ESM Setpoints are maintained. See ESM Setpoints for more information.

Minimized Display Mode

Optionally, you can set the thermostat to show only the temperature in minimized display mode. This mode can be enabled or disabled in the Users Settings screen.

→ See *Screen Timeout* on page [14](#) for more information.

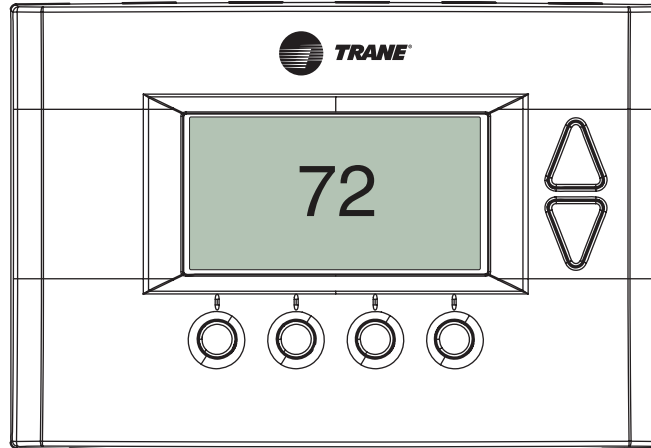

Menu Map

The menus are accessed by pressing the **MENU** button on the main screen.

A. "User Settings"

1. Set Clock
2. Filter Service
3. Maint. Service
4. Screen Timeout
5. F/C Settings
6. Sensor Calibration
7. Backlite/Display

B. "Usage Graph"

C. "ESM Setpoints"

D. "ZWave Install"

E. "Thermostat Info"

F. "Installer Settings" (**hidden**)

1. Display Lock
2. System Settings
 - a. Mechanical Settings
 1. Type
 2. Fan Type
 3. C/O Type
 4. 2nd Stage Heat
 5. Aux Heat
 6. 2nd Stage Cool
 - b. Sched Enable
 - c. Recovery Enable
 - d. H/C Delta
 - e. H Delta Stg1 ON
 - f. H Delta Stg1 OFF
 - g. H Delta Stg2 ON
 - h. H Delta Stg2 OFF
 - i. H Delta Stg3 ON
 - j. H Delta Stg3 OFF
 - k. C Delta Stg1 ON
 - l. C Delta Stg1 OFF
 - m. C Delta Stg2 ON
 - n. C Delta Stg2 OFF
3. Fan Cyclers
4. Min Cool SP
5. Min Run Time
6. Min Off Time
7. T-Sense Match
8. Fan Cyclers
 - a. Fan ON Time
 - b. Fan OFF Time
9. Restore Defaults

G. "Schedules" (**disabled by default**)

1. Heat and Cool
2. Preset: Comfort
3. Preset: EnergyStar
4. Copy (small c on each schedule screen)

User Settings

A.1 Set Clock

The Set Clock screen allows you to set the thermostat's internal clock.

- ➔ If the clock has been reset by an extended power outage, press the **MENU** button, scroll to the User Settings button and select, select the **Set Clock** screen and set clock.

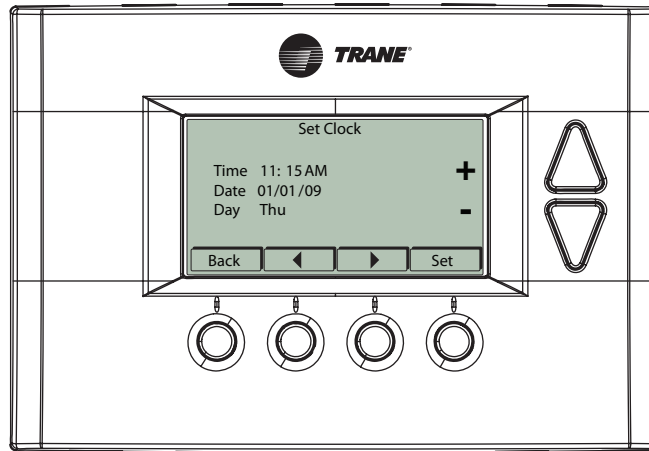

Set the Clock

1. Press the **MENU** button.
2. Scroll to **User Settings** and press the **Select** button.
3. Scroll to **Set Clock** and press the **Select** button.
4. Scroll to the item you want to change (hour, minute, day part, month, day, year, day of week).
5. Press the plus (+) or minus (-) buttons to adjust the item.
6. Press the **Set** button to save the changes.

Filter Service

The Filter Service screen will show the accumulated Filter Runtime hours as well as the Service Interval that will be used to trigger a Filter Message. Any type of HVAC operation that causes the HVAC system fan to run will cause the Filter Runtime value to increase.

When the Runtime hours equals the Service Interval hours, a “Filter” message will appear to remind you to replace the media filter or service the air cleaner. Once the filter has been replaced, press the Reset button to reset the Filter Runtime value to zero.

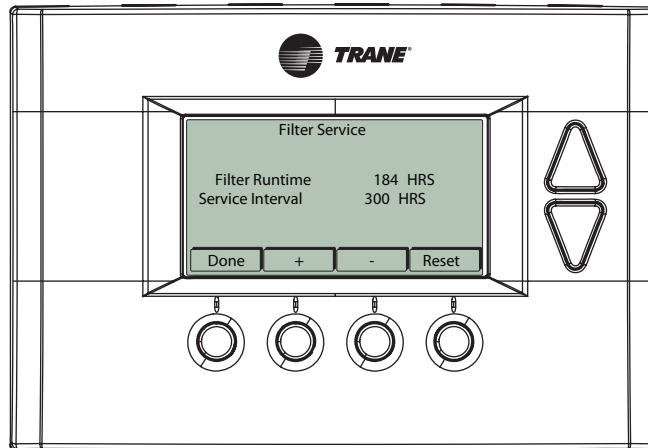

View/Reset Filter Runtime

1. Press the **MENU** button.
2. Scroll to **User Settings** and press the **Select** button.
3. Scroll to **Filter Service** and press the **Select** button. The Filter Runtime is displayed in hours.
4. To reset the Filter Runtime counter, press the **Reset** button.

➔ The Filter Runtime counter should be reset each time the filter is changed.

Change the Filter Service Interval

1. Press the **MENU** button.
2. Scroll to **User Settings** and press the **Select** button.
3. Scroll to **Filter Service** and press the **Select** button.
4. Press the plus (+) or minus (-) buttons to adjust the service interval.

➔ The service interval can be set between 100 and 4000 hours in 100 hour increments. Factory default is 300 hours.

Disable the Filter Service Interval

When the filter service interval is disabled, the runtime counter will continue to count the runtime, but the filter service indicator will never be displayed.

1. Press the **MENU** button.
2. Scroll to **User Settings** and press the **Select** button.
3. Scroll to **Filter Service** and press the **Select** button.
4. Press the minus (-) button until **Disabled** is displayed

Maint Service

The Maintenance Service screen shows the accumulated Heat and Cool Runtime hours as well as the Service Interval that will be used to trigger a Maintenance Message. Any HEAT or COOL type of HVAC operation will cause the respective Runtime values to increase.

When the combined HEAT and COOL Runtime hours equals the Service Interval hours, a “Maint” message will appear to remind you your HVAC system may require periodic maintenance. Press the **Menu** button to enter the Maintenance Service screen. The Reset button can be pressed and the HEAT and COOL Runtime values will be reset to zero.

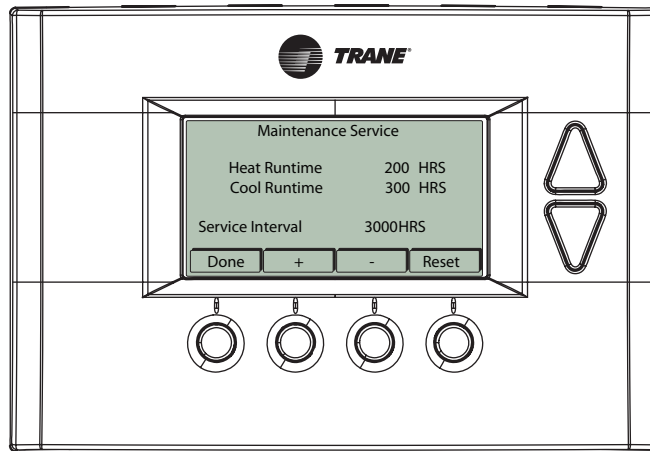

Change the Maintenance Service Interval

1. Press the **MENU** button.
2. Scroll to **User Settings** and press the **Select** button.
3. Scroll to **Maint Service** and press the **Select** button.
4. Press the plus (+) or minus (-) buttons to adjust the service interval.
→ The service interval can be set between 200 and 4000 hours in 100 hour increments.

Disable the Maintenance Service Interval

When the maintenance service interval is disabled, the runtime counter will continue to count the runtime, but the maintenance service indicator will never be displayed.

1. Press the **MENU** button.
2. Scroll to **User Settings** and press the **Select** button.
3. Scroll to **Maint Service** and press the **Select** button.
4. Press the minus (-) button until **Disabled** is displayed

Screen Timeout

This is the time before any screen reverts to the Minimized Screen (temperature display only), after you stop pushing buttons. Minimized Screen feature is disabled by setting this time to “0”.

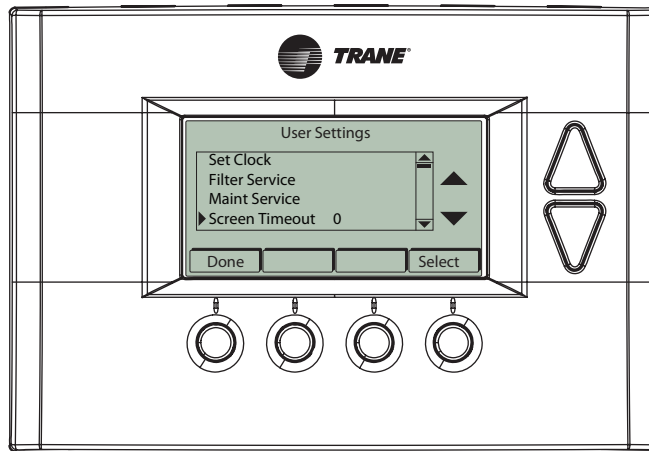

Change the Screen Timeout

1. Press the **MENU** button.
2. Scroll to **User Settings** and press the **Select** button.
3. Scroll to **Screen Timeout**
4. Press the plus (+) or minus (-) buttons to adjust the time (in seconds).
 - ➔ The screen time-out can be set between 0 and 120 seconds. Zero (0) is the default setting. When set to Zero (0), the minimized screen feature is disabled.

Disable the Minimized Display

1. Press the **MENU** button.
2. Scroll to **User Settings** and press the **Select** button.
3. Scroll to **Screen Timeout**
4. Press the minus (-) button until zero (0) is displayed.

F/C Settings

The F/C Settings screen is use to select the temperature display mode. Fahrenheit (F) or Celsius (C) are the two available modes.

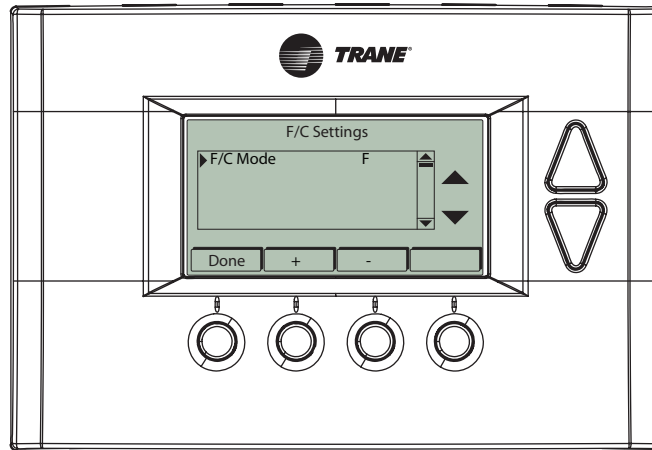

Change the Temperature Mode

1. Press the **MENU** button.
2. Scroll to **User Settings** and press the **Select** button.
3. Scroll to **F/C Settings** and press the **Select** button.
4. Press the plus (+) or minus (-) buttons to change the temperature mode. Select F for Fahrenheit or C for Celsius.

Sensor Calibration

The Sensor Calibration screen is used to change the temperature calibration of the internal temperature sensor. The temperature calibration can be changed by +/- 7 degrees.

When the Sensor Calibration screen is selected, the current temperature calibration is displayed. In the example screen, the calibrated temperature is 77 and the number of degrees of offset being applied is 1.

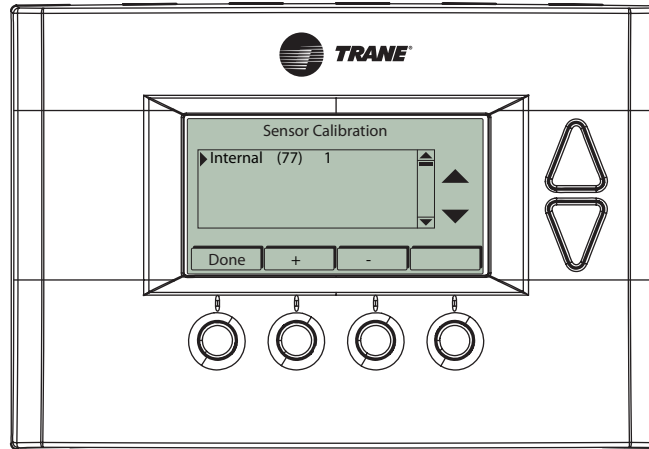

Change the Sensor Calibration

1. Press the **MENU** button.
2. Scroll to **User Settings** and press the **Select** button.
3. Scroll to **Sensor Calibration** and press the **Select** button.
4. Press the plus (+) or minus (-) buttons to change the sensor calibration.
 - ➔ After this screen is closed, it may take a few seconds for the temperature displayed on the main thermostat screen to update to the new temperature.

Backlite/Display

The Backlite/Display screen is used to set the backlight time-out and contrast.

Backlite Timeout is the time (in seconds) from the last button press to the backlight going out. The time-out can be set between zero (0) and one hundred and twenty (120) seconds. Thirty (30) is the default setting. When set to zero (0), the backlight will remain always on.

Contrast sets the contrast level of the LCD display. The contrast can be set between zero (0) and twenty (20). Ten (10) is the default setting. If the display is too light, using a higher number. If dark lines appear in the display, use a lower number.

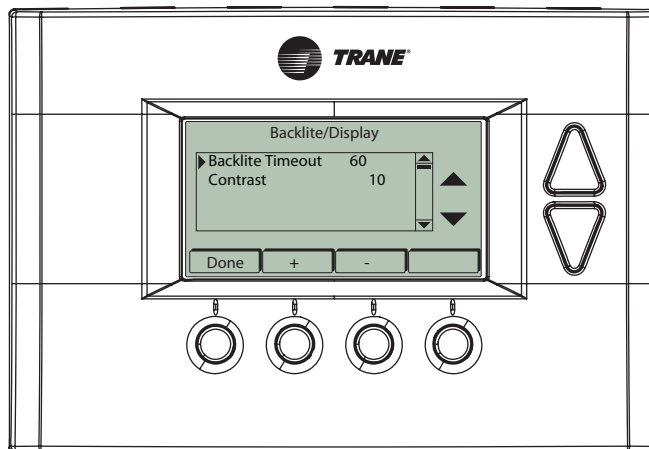

Adjust the Backlight

1. Press the **MENU** button.
2. Scroll to **User Settings** and press the **Select** button.
3. Scroll to **Backlite/Display** and press the **Select** button.
4. Scroll to **Backlite Timeout**.
5. Press the plus (+) or minus (-) buttons to change the number of seconds.
 - ➔ The backlight time-out can be set between 0 and 120 seconds. Thirty (30) is the default setting. When set to Zero (0), the backlight will remain always on.

Adjust the Contrast

1. Press the **MENU** button.
2. Scroll to **User Settings** and press the **Select** button.
3. Scroll to **Backlite/Display** and press the **Select** button.
4. Scroll to **Contrast**.
5. Press the plus (+) or minus (-) buttons to change the contrast value.
 - ➔ The contrast can be set between 0 and 20. Ten (10) is the default setting.

Usage Graph

The Usage Graph shows daily heating and cooling runtime hours for a week.

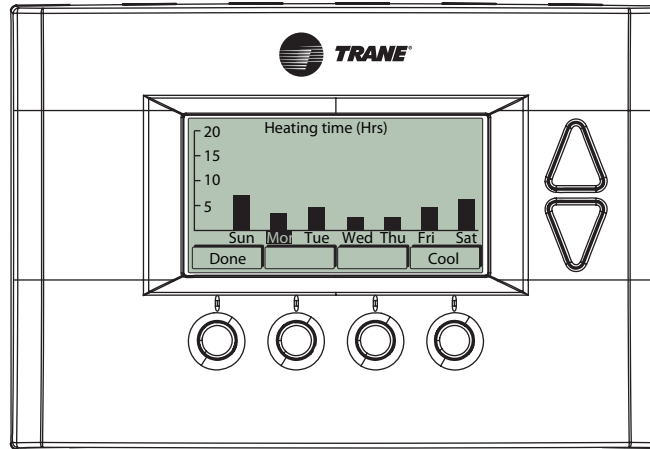

The button in the lower right corner will change depending on what is being displayed. When the heating time is displayed, the button will read *Cool*. When the cooling time is displayed, the button will read *Heat*. Press the *Heat/Cool* button to display the heating/cooling time.

ESM Setpoints

Energy Saving Mode (ESM) Setpoints are the setpoints used when the *Energy Saving Mode* schedule is selected in the *Schedule Mode* screen.

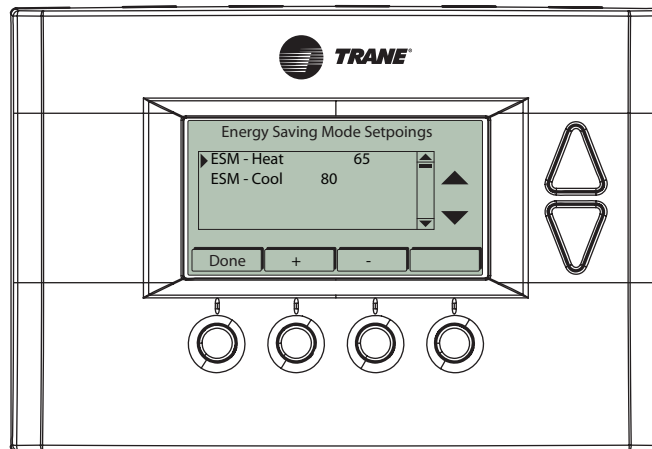

Adjust ESM Setpoints

1. Press the *MENU* button.
2. Scroll to *ESM Setpoints* and press the *Select* button.
3. To adjust the heat setpoint, scroll to *ESM - Heat*. Press the plus (+) or minus (-) buttons to adjust the setpoint.
4. To adjust the cool setpoint, scroll to *ESM - Cool*. Press the plus (+) or minus (-) buttons to adjust the setpoint.

ZWave Install

Z-Wave™ controllers from various manufacturers may support the Z-Wave™ Thermostat General V2 Device class used by the Trane Z-Wave™ Thermostat. The following procedure will allow the thermostat to be added to a Z-Wave™ network.

- ➔ If you are using a controller that is not a Schlage bridge, consult the instructions that came with the controller to find out how to enroll a new device.

Inclusion

1. Install a new, high-quality 9-volt battery into the bridge.
2. Hold the bridge within 6 feet (1.8 meters) of the thermostat throughout the entire inclusion process.
 - ➔ After you begin the inclusion process, you have 30 seconds to complete the remainder of the steps. Study the steps below before beginning.
3. Press and release the plus (+) button on the bridge.
4. Press the **MENU** button on the thermostat.
5. Scroll to **ZWave Install**. Then press the **Select** button.
6. Press the **Yes** button.
7. Observe the lights on the bridge. The orange light will blink while enrollment is taking place. Enrollment is complete when the orange light becomes solid.

Exclusion

1. Install a new, high-quality 9-volt battery into the bridge.
2. Hold the bridge within 6 feet (1.8 meters) of the thermostat throughout the entire exclusion process.
 - ➔ Note: After you begin the enrollment process, you have 30 seconds to complete the remainder of the steps. Study the steps below before beginning.
3. Press and release the minus (-) button on the bridge.
4. Press the **MENU** button on the thermostat.
5. Scroll down to **Z-Wave Install** and press the **Select** button.
6. Press the **Yes** button to exclude the thermostat.
7. Observe the lights on the bridge. The orange light will blink while exclusion is taking place. Exclusion is complete when the orange light becomes solid.

Inclusion and Exclusion with Other Controllers

Inclusion or exclusion is started by putting the controller into add node or remove node state and performing the procedure outlined above. As part of the process, the thermostat sends a node information frame at normal power. Low power inclusion or low power exclusion is not possible.

Thermostat Info

The Thermostat Info screen displays information about the thermostat and the system the thermostat controls. This information will be helpful if you need to contact customer support.

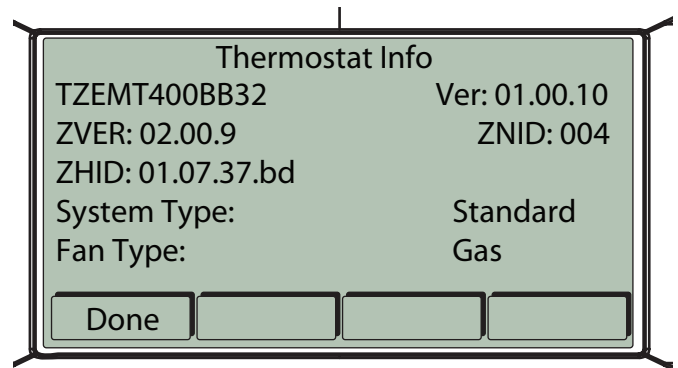
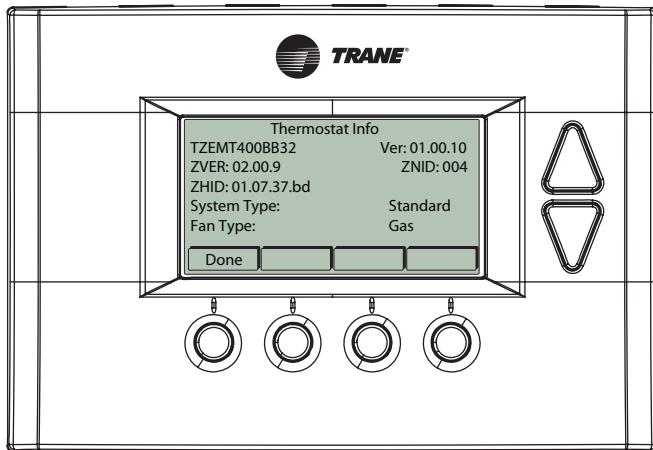

Item	Description
TZEMT400BB32	Model Number
Ver: 01.00.10	Firmware version → This number may vary.
ZVER: 02.00.9	Z-Wave version → This number may vary.
ZNID: 004	Z-Wave node ID → This number may vary.
ZHID: 01.07.37.bd	Z-Wave Home ID → This number may vary.
System Type: Standard	System type may be Standard or Heatpump
Fan Type: Gas	Fan type may be Gas or Elect (electric)

Installer Settings

➔ *The Installer Settings screen is a hidden screen designed for installer use only. Do not change any settings in this screen unless you are a qualified service technician.*

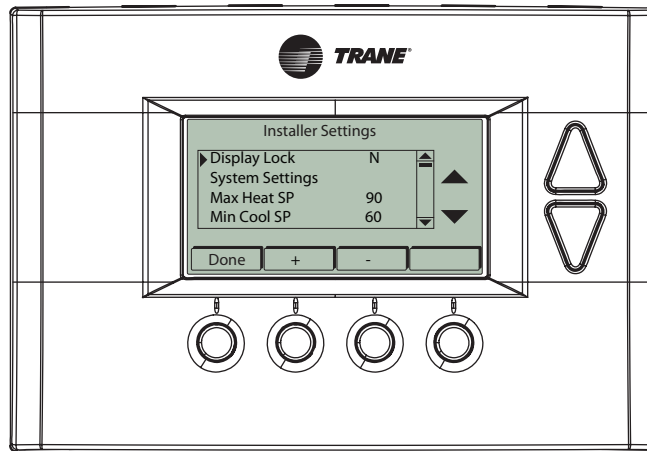

➔ *Changing these settings will affect the operation of the heating/cooling system.*

To view and edit these settings:

1. Press the **MENU** button.
2. Press and hold the two middle buttons simultaneously until the **Installer Settings** menu is displayed.
3. Scroll to the setting you want to change. Press the plus (+) or minus (-) button to adjust the setting.
4. Press the **Done** button when you are finished.

Setting	Range	Default	Description
Display Lock	Y or N	N	Locks or unlocks the thermostat buttons. When the buttons are locked, the main menu can still be accessed, but no menu options may be selected. The Installer Settings hidden button operation is always operational, allowing Display Lock to be turned off.
Max Heat SP	55F to 90F (12C-32C)	90F (32C)	Sets the maximum heating setpoint value. Will not ramp or accept setpoints higher than this maximum.
Min Cool SP	60F to 99F (15C-37C)	60F (15C)	Sets the minimum cooling setpoint value. Will not ramp or accept setpoints lower than this minimum.
Minimum Run Time (MRT)	1- 9 Minutes	3	Sets the minimum run time before a heating/cooling cycle can turn off to prevent rapid cycling. Thermostat screen will display Cool ON or Heat ON while the minimum run time is being enforced.
Minimum Off Time (MOT)	5-9 Minutes	5	Sets the minimum off time before another heating/cooling cycle can begin to provide compressor short cycle protection. Thermostat screen will display WAIT when minimum off time is being enforced.
T-Sense Match	1-6	2	Sample rate of temperature sensor Low Sample Rate = Less sensitive (slower response) High Sample Rate = More sensitive (faster response)
Restore Defaults	n/a	n/a	Sets all of the thermostat settings back to the factory defaults.

System Settings

→ *Changing these settings will affect the operation of the heating/cooling system.*

To view and edit these settings:

1. Press the **MENU** button.
2. Press and hold the two middle buttons simultaneously until the **Installer Settings** menu is displayed.
3. Scroll to System Settings and press the **Select** button.
4. Scroll to the setting you want to change. Press the plus (+) or minus (-) button to adjust the setting.
5. Press the **Done** button when you are finished.

→ **Note on Delta Settings:** The Delta T Setting is the delta, or difference between, the setpoint and current temp for determining when a heat or cool call comes on. The “delta” is the number of degrees away from setpoint.

Setting	Range	Default	Description
Schedule Enable	Y or N	N	When enabled, the local thermostats scheduler function is enabled.
Recovery Enable	Y or N	N	See Thermostat Recovery Operation below.
H/C Delta	3 - 15 degrees	3	Sets the minimum separation between heating and cooling setpoints. Attempts to lower the cooling below the heating setpoint by this amount will PUSH the heating setpoint down to maintain this separation. Same for setting the heating setpoint above the cooling setpoint, it will PUSH the cooling setpoint up to maintain this separation.
Heating Delta Stage 1 ON	1 to 8 degrees	1	Sets the delta from setpoint that stage 1 heating starts.
Heating Delta Stage 1 OFF	0 to 8 degrees	0	Sets the delta from setpoint that stage 1 heating stops. Stage 1 turns off at setpoint minus (-) Delta Stage 1.
Heating Delta Stage 2 ON	1 to 8 degrees	2	Sets the delta from setpoint that stage 2 heating starts.
Heating Delta Stage 2 OFF	0 to 8 degrees	0	Sets the delta from setpoint that stage 2 heating stops. Stage 2 turns off at setpoint minus (-) Delta Stage 2.
Heating Delta Stage 3 ON	1 to 8 degrees	3	Sets the delta from setpoint that stage 3 heating starts.
Heating Delta Stage 3 OFF	0 to 8 degrees	0	Sets the delta from setpoint that stage 1 heating stops. Stage 3 turns off at setpoint minus (-) Delta Stage 3.
Cooling Delta Stage 1 ON	1 to 8 degrees	1	Sets the delta from setpoint that stage 1 cooling starts.
Cooling Delta Stage 1 OFF	0 to 8 degrees	0	Sets the delta from setpoint that stage 1 Cooling stops. Stage 1 turns off at setpoint plus (+) Delta Stage 1.
Cooling Delta Stage 2 ON	1 to 8 degrees	2	Sets the delta from setpoint that stage 2 cooling starts.
Cooling Delta Stage 2 OFF	0 to 8 degrees	0	Sets the delta from setpoint that stage 2 Cooling stops. Stage 2 turns off at setpoint plus (+) Delta Stage 2.

Thermostat Recovery Operation

The Recover feature is active only when “Schedule” is enabled and the schedule mode is set to “RUN”

Recovery operation, when enabled, will start the cooling or heating system so that the desired comfort temperature is reached by the next scheduled set point time. The advance start time calculation is a learned process that is recalculated and adjusted each day until the room temperature is at the target temperature at the schedule time. When the thermostat is in Recovery mode the display will show “Recov”.

Recovery works for all scheduled periods (1-4) and in HEAT, COOL or AUTO modes. While in Recovery the Aux-Heat stage will not engage.

The maximum Recovery time is one hour.

Mechanical Settings

→ *Changing these settings will affect the operation of the heating/cooling system.*

To view and edit these settings:

1. Press the **MENU** button.
2. Press and hold the two middle buttons simultaneously until the **Installer Settings** menu is displayed.
3. Scroll to **System Settings** and press the **Select** button.
4. Scroll to **Mechanical Settings** and press the **Select** button.
5. Scroll to the setting you want to change. Press the plus (+) or minus (-) button to adjust the setting.
6. Press the **Done** button when you are finished.

Setting	Range	Default	Description
Type	Gas/Elec or Heatpump	Gas/Elec	Selects HVAC type, Gas/Electric or Heatpump
Fan Type	Gas or Elec	Gas	Selects the Fan type if system is Gas or Electric
C/O Type	w/Cool or w/Heat	w/Cool	Set the Heat pump Changeover type
2nd Stage Heat	Y or N	N	Enables the 2nd Stage Heat operation
Aux Heat (HP)	Y or N	Y	Enables the Auxiliary Heat operation. Typically the Aux Heat will be heat-strips in a Heatpump system
2nd Stage Cool	Y or N	N	Enables the 2nd Stage Cool operation

Fan Cyclor Settings

→ *Changing these settings will affect the operation of the heating/cooling system.*

To view and edit these settings:

1. Press the **MENU** button.
2. Press and hold the two middle buttons simultaneously until the **Installer Settings** menu is displayed.
3. Scroll to **Fan Cyclor** and press the **Select** button.
4. Scroll to the setting you want to change. Press the plus (+) or minus (-) button to adjust the setting.
5. Press the **Done** button when you are finished.

Setting	Range	Default	Description
Fan ON Time	0-120 minutes	0 (=OFF)	The fan cyclor function cycles the HVAC system fan for an ON period followed by an Off period continuously. Used to provide minimum air ventilation requirements. When the Fan ON time is set to a value greater than 0, an additional Cyclor FAN mode is present when pressing the FAN button.
Fan OFF Time	10-120 minutes	10	

Schedules

Scheduling is usually controlled by your Z-Wave system. See the instructions that came with your Z-Wave system for more information. However, scheduling may also be controlled by the thermostat.

- The Schedules menu is hidden by default, but may be enabled in the Installer Settings. See *Enable/Disable the Schedules Menu* on page 19 for more information.

The thermostat has a 4 x 7 schedule, meaning the setpoints can be changed up to four times a day each day. Each day has a separate schedule. Schedules may be copied from one day to another day or group of days. See *Copy a Day Schedule* on page 23 for more information.

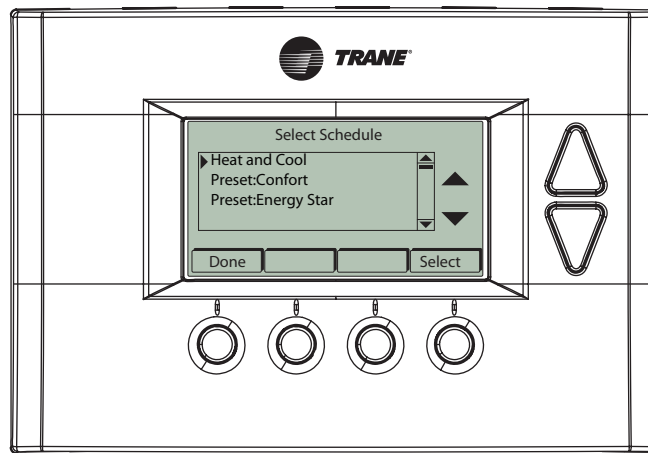

Enable/Disable the Schedules Menu

Because the Schedules menu is disabled by default, you must first enable it before any scheduling can be done at the thermostat. If you want to use your Z-Wave system for scheduling, scheduling must be disabled in the thermostat.

1. Press the **MENU** button.
 2. Press and hold the two middle buttons simultaneously until the **Installer Settings** menu is displayed.
 3. Scroll to **Systems Settings** and press the **Select** button.
 4. Scroll to Sched Enable and press the **plus (+)** button to enable scheduling or the **minus (-)** button to disable scheduling.
- When scheduling is enabled in the thermostat, a **Y** will be displayed next to **Sched Enable**. When scheduling is disabled in the thermostat, an **N** will be displayed next to **Sched Enable**.

Load a Preset Schedule

There are two possible schedules that may be loaded: Preset Comfort and Preset Energy Star. These schedules may not be changed. When a schedule is loaded, it changes the current Heat and Cool schedule settings. You can then edit the Heat and Cool schedule, if necessary.

➔ *Selecting Preset Comfort or Preset Energy Star schedules will overwrite the current Heat and Cool schedule.*

1. Press the **MENU** button.
2. Scroll to **Schedules** and press the **Select** button.
3. Scroll to the schedule you want to load and press the **Select** button.
4. Press the **Yes** button.

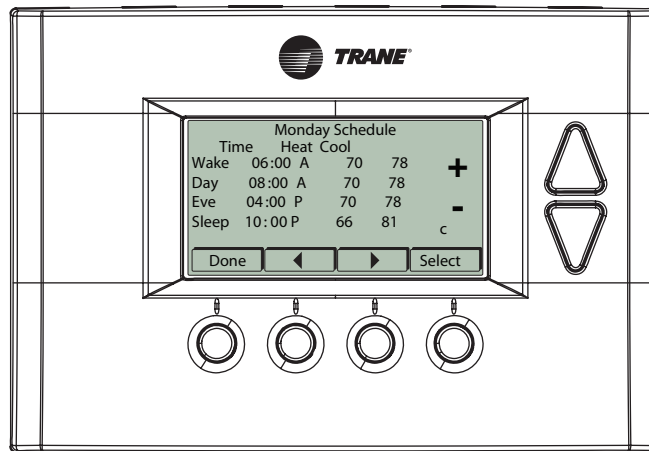

Preset Schedule	Description
Preset: Comfort	This is a preset schedule with mild setbacks, designed to maintain a comfortable temperature.
Preset: Energy Star	This is a preset schedule with deeper setbacks, designed to conserve energy.

View the Current Schedule

1. Press the **MENU** button.
2. Scroll to **Schedules** and press the **Select** button.
3. Scroll to **Heat and Cool** and press the **Select** button.
4. The schedule for the current day will be displayed. To view other days, press the **Next** button.

Set a Heat and Cool Schedule

1. Press the **MENU** button.
2. Scroll to **Schedules** and press the **Select** button.
3. Scroll to **Heat and Cool** and press the **Select** button.
4. The schedule for the current day will be displayed. To view other days, press the **Next** button.
5. To change a setting (hour, minute, day part, heat setpoint or cool setpoint), scroll to that setting using the left (◀) or right (▶) arrow buttons. Then press the plus (+) or minus (-) buttons as necessary.
➔ Continue pressing the left (◀) or right (▶) arrow buttons to move to the next line.

Copy a Day Schedule

1. Press the ***MENU*** button.
2. Scroll to ***Schedules*** and press the ***Select*** button.
3. Scroll to ***Heat and Cool*** and press the ***Select*** button.
4. The day of the week is displayed at the top of the screen. Press the Next button until the day you want to copy is displayed.
5. Highlight the small ***c*** in the lower right corner by pressing the left arrow (◀) button once. The ***Next*** button will change to ***Copy***.
6. Press the ***Copy*** button.
7. For each day to which you want to copy the day schedule, change the ***N*** (no) to ***Y*** (yes). Use the left (◀) or right (▶) arrow buttons to scroll to the day and the use the ***Yes*** or ***No*** buttons on the side of the screen.
8. Press the ***Copy*** button.

Installation

For complete installation instructions, browse to part2.schlage.com and download *Trane Thermostat Installation Instructions*.

Warranty

Trane Remote Energy Management Thermostat Limited One (1)-Year Electronics and Mechanical Warranty

U.S.A. and Canada Only

Subject to the terms and conditions of this Limited One (1)-Year Electronics and Mechanical Warranty, Trane warrants that, if within one (1) year from Original Date of Purchase, the Purchased Product fails due to defect in manufacture, material or workmanship, Trane will provide a replacement for the Purchased Product or refund the Original Purchase Price, at its sole option, to the Original Purchaser occupying the premises in which the Purchased Product was originally installed. This warranty applies to the Original Purchaser only and is non-transferable. The one (1)-year limited warranty period begins from Original Date of Purchase, confirmed by sales receipt or other dated proof of purchase.

Exclusions: The following costs, expenses and damages are not covered by the terms and conditions of this One(1)-Year Limited Electronics and Mechanical Warranty: (i) labor and costs including, but not limited to, original initial installation, removal and reinstallation of Purchased Product; (ii) shipping and freight expenses for any required return of Purchased Product; (iii) failures, defects, or damages (including, but not limited to, any security failure or loss of data) caused by any third party product, service, or system connected or used in conjunction with the Purchased Product; and (iv) any other incidental, consequential, indirect, special and/or punitive damages, whether based on contract, warranty (express or implied), tort (including, but not limited to, strict liability or negligence), patent infringement, or otherwise, even if advised of the possibility of such damages. Additionally, this limited warranty does not cover scratches, abrasions, or deterioration due to the use of paints, solvents or other chemicals.

Further, the terms and conditions of this One (1)-Year Limited Electronics and Mechanical Warranty do not apply to Purchased Product when: (1) used in common area applications (2) used for purposes for which it was not designed or intended; (3) subjected to alteration, modification, abuse, misuse, negligence or accident, improper storage, improper installation or maintenance or operation or unauthorized repair; (4) used in violation of written instructions provided for Purchased Product; (5) subjected to improper temperature, humidity or other environmental conditions; or (6) damaged as a result of acts of God.

This One (1)-Year Limited Electronics and Mechanical Warranty is the only express warranty Trane makes on this product. THE DURATION OF ANY IMPLIED WARRANTIES, INCLUDING THE WARRANTIES OF MERCHANTABILITY AND FITNESS FOR A PARTICULAR PURPOSE, IS HEREBY LIMITED TO THE ONE-YEAR DURATION OF THIS WARRANTY. IF THIS PURCHASED PRODUCT IS CONSIDERED A CONSUMER PRODUCT, SOME STATES DO NOT ALLOW THE EXCLUSION OR LIMITATION OF INCIDENTAL OR CONSEQUENTIAL DAMAGES, SO THIS LIMITATION MAY NOT APPLY TO YOU. REFER TO YOUR LOCAL LAWS FOR YOUR SPECIFIC RIGHTS UNDER THIS WARRANTY.

Additional items: Trane does not authorize any person to create for it any obligation or liability in connection with the Purchased Product. Trane's maximum liability hereunder is limited to the Original Purchase Price of the Purchased Product. No action arising out of any claimed breach of this warranty by Trane may be brought by the Original Purchaser more than one (1) year after the cause of action has arisen.

If you have a claim under this warranty, please return the Purchased Product to place of purchase for replacement or refund of the Original Purchase Price in exchange for the return of the Purchased Product, including sales receipt or other dated proof of purchase. Contact Schlage Customer Service at 877-288-7707 in U.S.A. and Canada for assistance with set-up and installation, or questions regarding your warranty claim.

Index

Symbols

2nd Stage Cool 20
2nd Stage Heat 20

A

Adjust
 Backlight 13
 Contrast 13
 ESM Setpoints 15
Aux Heat (HP) 20

B

Backlight
 Adjust 13
Backlite 13
Backlite/Display 13
Button
 Menu 4
Buttons
 Function Control 4
 Setpoint 3

C

Calibration
 Sensor 12
Celsius 11
Change
 Filter Service Interval 8
 Maintenance Service Interval 9
 Screen Timeout 10
 Sensor Calibration 12
 Temperature Mode 11
Clock
 Display 3
 Set 7
Comfort Schedule 22
Contrast 13
 Adjust 13
Cooling Delta Stage 1 OFF 19
Cooling Delta Stage 1 ON 19
Cooling Delta Stage 2 OFF 19
Cooling Delta Stage 2 ON 19
Copy
 Schedule 23
C/O Type 20

D

Defaults
 Restore 18
Disable
 Filter Service Interval 8
 Maintenance Service Interval 9
 Minimized Display 10
 Schedules 21
Display
 Clock 3
 Setpoint 3
 Temperature 3
Display Lock 18
Dynamic Labels 3

E

Enable
 Recovery 19
 Schedule 19
 Schedules 21
Energy Star
 Schedule 22
ESM (Energy Savings Mode) Setpoints
 15
 Adjust 15
Exclusion 16

F

Fahrenheit 11
Fan
 Mode 4
Fan Cyclers Settings 20
Fan OFF Time 20
Fan ON Time 20
Fan Type 20
F/C Settings 11
Filter Service 8
 View/Reset Filter Runtime 8
Filter Service Interval
 Change 8
 Disable 8
Function Control Buttons 4
 Thermostat Control Screen 3

H

H/C Delta 19
Heating Delta Stage 1 OFF 19
Heating Delta Stage 1 ON 19
Heating Delta Stage 2 OFF 19
Heating Delta Stage 2 ON 19
Heating Delta Stage 3 OFF 19
Heating Delta Stage 3 ON 19

I

Inclusion 16
Installation 24
Installer Settings 18

L

Labels
 Dynamic 3
Load
 Preset Schedule 22

M

Maintenance Service 9
Maintenance Service Interval
 Change 9
 Disable 9
Maint Service 9
Max Heat SP 18
Mechanical Settings 20

Menu

 Button 4
Menu Map 6
Min Cool SP 18
Minimized Display 5
 Disable 10
 Mode 5
Minimum Off Time 18
Minimum Run Time 18
Mode
 Fan 4
 Minimized Display 5
 Schedule 4
 System 4
 Temperature 11
MOT 18
MRT 18

O

Operation 3

P

Preset Schedule
 Load 22

R

Recovery Enable 19
Restore Defaults 18

S

Schedule
 Comfort 22
 Copy 23
 Energy Star 22
 Load Preset 22
 Mode 4
 Preset 22
 Set 22
 View 22
Schedule Enable 19
Schedules 21
 Disable 21
 Enable 21
Screen Timeout 10
 Change 10
Sensor Calibration 12
 Change 12
Service
 Maintenance 9
Set
 Clock 7
 Schedule 22
Setpoints
 Display 3
 ESM (Energy Savings Mode) 15
 Up/Down Buttons 3

Settings
Fan Cyclor 20
Installer 18
Mechanical 20
User 7
Specifications 2
System
Mode 4
System Settings 19

T
T-Sense Match 18
Temperature
Display 3
Mode 11
Temperature Mode
Change 11
Thermostat control screen 3
Thermostat Control Screen
Function Control Buttons 4
Thermostat Info 17
Type 20

U
Usage Graph 14
User Settings 7

V
View
Filter Runtime 8
Schedule 22

W
Warranty 25

Z
Z-Wave
Exclusion 16
Inclusion 16
ZWave Install 16

FCC Notice

FCC ID WIBTZW008

INFORMATION TO USER

This device complies with Part 15 of the FCC Rules. Operation is subject to the following two conditions: (1) This device may not cause harmful interference, and (2) This device must accept any interference received, including interference that may cause undesired operation.

This equipment has been tested and found to comply with the limits for Class B Digital Device, pursuant to Part 15 of the FCC Rules. These limits are designed to provide reasonable protection against harmful interference in a residential installation. This equipment generates and can radiate radio frequency energy and, if not installed and used in accordance with the instructions, may cause harmful interference to radio communications. However, there is no guarantee that interference will not occur in a particular installation. If this equipment does cause harmful interference to radio or television reception, which can be determined by turning the equipment off and on, the user is encouraged to try to correct the interference by one or more of the following measures.

- Reorient or relocate the receiving antenna
- Increase the separation between the equipment and receiver
- Connect the equipment into an outlet on a circuit different from that to which the receiver is connected
- Consult the dealer or an experienced radio/TV technician for help

Any changes or modifications not expressly approved by the party responsible for compliance could void the user's authority to operate the equipment.

IC Notice

IC 9374A-TZ45

This device complies with Industry Canada license-exempt RSS standard(s). Operation is subject to the following two conditions: (1) this device may not cause interference, and (2) this device must accept any interference, including interference that may cause undesired operation of the device.

Le présent appareil est conforme aux CNR d'Industrie Canada applicables aux appareils radio exempts de licence. L'exploitation est autorisée aux deux conditions suivantes : (1) l'appareil ne doit pas produire de brouillage, et (2) l'utilisateur de l'appareil doit accepter tout brouillage radioélectrique subi, même si le brouillage est susceptible d'en compromettre le fonctionnement.

