

TRION[®]

Air Purification Systems



READ AND SAVE THESE INSTRUCTIONS

Comfort**BREEZE**[™] CB707

Centrifugal Atomizing Humidifier



READ AND SAVE THESE INSTRUCTIONS
LIRE ET CONSERVER CES INSTRUCTIONS

TABLE OF CONTENTS

1. Warranty Statement 3
2. Safety Warnings 3
3. Introduction 4
 3.1 Basic Operation 4
 3.2 Specifications Table 4
 3.3 What's in the Box 4
 3.4 Hardware Details 4
4. Installation 5
 4.1 Clearances 5
 4.2 Selecting a location 5
 4.2.1 Wall Mounting 5
 4.2.2 Duct Mounting 6
 4.2.3 Ceiling Mounting 6
 4.2.4 Shelf Mounting 7
 4.3 Plumbing 7
 4.4 Electrical/Wiring 7
5. Operation 8
 5.1 Preliminary Checkout 8
 5.2 Starting and Stopping the humidifier 8
 5.3 End Of Season Decommissioning 8
6. Maintenance/Troubleshooting 8
 6.1 Cleaning Instructions 9
 6.2 Control Board Faults & Reset 10
 6.3 Troubleshooting Chart 11
 6.4 Exploded View/Parts List 12

1. Warranty

Humidifier 5-Year Limited Warranty

This limited warranty covers Trion Residential Type Humidifiers, excluding duct work, wiring and installation. Trion warrants that all new Trion humidifiers are free from defects in material and workmanship under normal, non-commercial use and service. Trion will remedy any covered defects if they appear within 60 months from the date of original installation & subject to the terms and conditions of this Limited 5-Year Warranty stated below:

1. THIS LIMITED 5-YEAR WARRANTY is granted by Trion Customer Service, 101 McNeill Road, Sanford, NC 27330.
2. This warranty shall extend only to any non-commercial owner who has purchased the residential humidifier other than for purposes of resale.
3. All components are covered by this limited warranty except expendable items, such as evaporative pads, media filter pads and nozzles.
4. If, within the warranty period, any Trion residential humidifier unit or component requires service it must be performed by a competent heating and/or air conditioning contractor (preferably the installing contractor). Trion will not pay shipping charges, or labor charges to remove or replace such defective parts or components. If the part or component is found by inspection to contain such defective material and workmanship it will be either repaired or exchanged free of charge at Trion's option, and returned freight collect.
5. In order to obtain the benefits of this limited 5-year warranty, the owner must notify the dealer or distributor of any defect within 30 days of its discovery. If after reasonable time you have not received an adequate response from the dealer or distributor, notify in writing to Trion Customer Service 101 McNeill Road, Sanford, NC 27330, or call 1-800-884-0002 or email customerservice@trioniaq.com Humidifiers which have been installed or become part of real estate cannot be returned. Trion will receive, freight prepaid, only removable parts or components of such defective humidifiers.
6. This limited warranty does not apply to any part or component that is damaged in transit or in handling, has been subject to misuse, neglect or accident; has not been installed, operated and serviced according to Trion's instructions; has been operated beyond the factory rated capacity; or altered in any such way that its performance is affected. There is no warranty due to neglect, alteration or ordinary wear and tear. Trion's liability is limited to replacement of defective parts or components and does not include the payment of the cost of labor charges to remove or replace such defective components or parts.
7. Trion will not be responsible for loss of use of any product; loss of time, inconvenience, or any other indirect, incidental or consequential damages with respect to person or property, whether as a result of breach of warranty, neglect or otherwise. SOME STATES DO NOT ALLOW THE EXCLUSION OR LIMITATION OF INCIDENTAL OR CONSEQUENTIAL DAMAGES, SO THE LIMITATION OR EXCLUSION IN THE PRECEDING SENTENCE MAY NOT APPLY TO YOU.
8. THIS WARRANTY GIVES YOU SPECIFIC RIGHTS, AND YOU MAY ALSO HAVE OTHER RIGHTS WHICH VARY FROM STATE TO STATE.
9. Any warranty by Trion of merchantability, fitness for use or any other warranty (express, implied or statutory), representation or guarantee other than those set forth herein, shall expire at the expiration date of this express limited warranty. SOME STATES DO NOT ALLOW LIMITATIONS ON HOW LONG AN IMPLIED WARRANTY LASTS, SO THE LIMITATION IN THE PRECEDING SENTENCE MAY NOT APPLY TO YOU.
10. Trion reserves the right to make changes in the design and material of its products without incurring any obligation to incorporate such changes in units completed on the effective date of such change.

2. Safety & Warnings

DANGER

RISK OF ELECTRIC SHOCK

Before cleaning, servicing, or parts replacement, the unit must be disconnected from all sources of electricity.

CAUTION

Read these instructions thoroughly before installing this unit. Check data label and verify electrical specifications agree with those at the point of installation.

WARNING

Improper installation, adjustment, alteration, service, or maintenance may cause property damage, injury, or death. This appliance must be installed according to these instructions. Read these instructions thoroughly before installing or servicing the unit.

WARNING

Failure to install this unit in a position that is level and plumb may impair the unit's ability to drain if an overflow condition presents itself. Damage to personal property may also result.

WARNING

Installation in freezing conditions can result in unit failure. Damage to personal property may also result.

WARNING

This appliance is not intended for use by children or persons with reduced physical, sensory or mental capabilities, or lack of experience and knowledge, unless they have been given supervision or instruction concerning use of the appliance by a person responsible for their safety. Children should be supervised to ensure that they do not play with the appliance

3. Introduction

The benefits of a properly humidified environment (35-55% Relative Humidity) are many. They include both personal comfort as well as the preservation of furniture, draperies, carpets, wooden floors and cabinets, paintings, pianos, etc. Your home can be more comfortable at a lower temperature (i.e.: 68° F) at 30-40% Relative Humidity (RH) than at 71° to 72° F without controlled humidity. Since every degree of temperature setback represents about 3% of your heating costs, this can represent a significant annual savings. During the heating season, cold air infiltrates the home and must be heated. When heated, this air dries out and greatly increases its capacity to hold more moisture. By using a humidifier, a source of water is provided to satisfy this increased moisture holding capacity, rather than having it drawn from occupants and the surrounding furnishings in the home.

3.1 Basic Operation

Your ComfortBREEZE™ centrifugal atomizing humidifier operates on the principles of atomization and evaporation. A rotating impeller pulls water from a small reservoir and slings it against a periphery of impaction posts inside the unit. The force of the impact causes the water to break into tiny droplets which are subsequently discharged from the unit into the air. Once the atomized water has exited the unit, it evaporates and raises the relative humidity of the air.

If applicable, set the humidistat in the recommended range of 30-40% relative humidity for automatic humidity control during the heating season. A lower setting may be necessary to prevent condensation on windows. If needed, an electronic humidistat is available to automatically reset the humidity setpoint as the outside air temperature changes.

During the first heating season, check the reservoir for mineral build-up periodically to establish a cleaning schedule. Clean the unit at the end of each heating season, or whenever mineral deposits appear to be impeding the performance of the humidifier. When shutting the humidifier down for the summer months, start by cleaning and mineral accumulation from the unit. Turn the water off to the unit and dry any remaining water from the reservoir. See Page 8 for End Of Season Decommissioning.

3.2 "What's In The Box?"

Part Number	Description
265562-001 or 265562-002	CB707 Humidifier
265160-001	Humidistat
265310-001	Wall/Duct Mount Bracket
266152-002	Nozzle Extension Tube
265631-001	IOM Manual
266004-001	Parts Bag

Hardware Details:

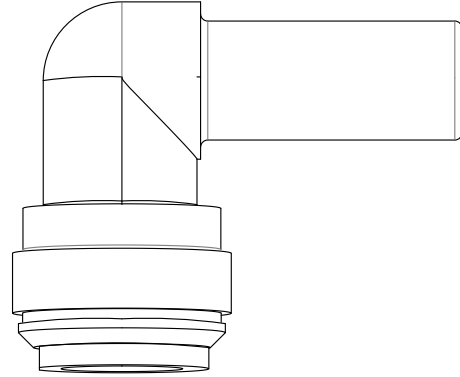

(1) Plug-in Elbow Tube Fitting 1/2" X 1/2"

P/N: 265570-001

Use: Attaches to the drain connection on the bottom of the unit for shelf mounted applications.



(4) #10 X 1/2" Plastite Screw & Rubber Feet

P/N: 265378-226 & 266201-001

Use: Attaches to the bottom of the base

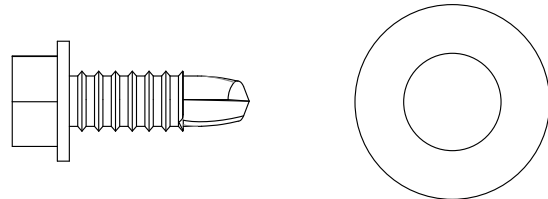

(6) #12 X 3/4" TEK Screw & #12 Flat Washer

P/N: 60645 & 120031-010

Use: Secures flange and mounting bracket to duct.

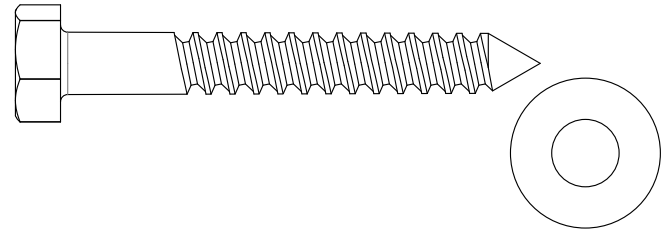

(2) 1/4" X 2" Lag Screw & 1/4" Flat Washer

P/N: EST-175 & 120031-011

Use: Attaches mounting bracket to wall stud.

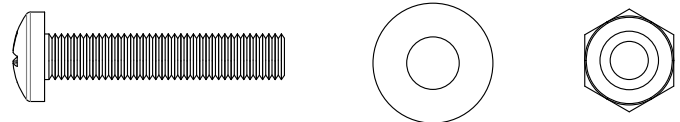

(2) #10-32 X 1" Pan Head Screw, #10 Flat washer, & #10-32 Nyloc Nut

P/N: 137790-310, 120031-009, & 123149-008

Use: Attaches unit to the mounting bracket.

3.3 Unit Specifications

Type of Unit	Centrifugal Atomizing
Mounting	Return Duct/Wall/Table-top/Ceiling
Capacity (GPD)	6 GPD, 2 Lbs./Hr., 0.9 Kg/Hr.
Water Supply	20-80 PSI (138-552 KPa)
Voltage(Amps)	120VAC(0.8A), 220VAC(0.4A)
Unit Dimensions	11"W x 9.5" D x 12" H 279mm W x 241mm D x 305mm H
Water Connection	1/4" (6.35 mm) OD Tubing
Overflow Connection	1/2" (12.7 mm) ID Tubing
Ducted Connection	3" Diameter (76 mm)
Shipping Weight	12.75 Lbs. (28 Kg)
Operating Weight	9 Lbs. (19.8 Kg)
Approvals	ETL (US & Canada) CE (220V)

4. Installation

Prior to installing this product:

- Read the instructions carefully and completely to ensure safe operation. Failure to follow the instructions could lead to damage to the product or cause a hazardous condition.
- Check the ratings given on the product to make sure it is suitable for your application.

Remember to select a location that is readily accessible for periodic inspection, cleaning, and service. The following table indicates the minimum allowable installation clearances.

4.1 Clearances

Left	2"
Right	2"
Top	5"
Bottom	0" (for surface mounting)
Back	2"

CAUTION

Trion recommends that this humidifier be installed by a trained HVAC professional. Do not connect the unit to the power source until the installation is complete. A thorough checkout of the unit installation should be completed before operating the unit. Failure to follow these directions may void the manufacturer's original warranty.

4.2 Selecting A Location

The ComfortBREEZE CB-707 Humidifier may be mounted directly to the return duct of your HVAC system with the discharge entering the ductwork, it may be wall-mounted for atmospheric dispersion, it may be hung from a ceiling (mounting hardware not included for this type of installation), or it may be simply mounted to a shelf. An indicating LED is located on the opposite side of the base from the plumbing and electrical connections. Ensure that this LED is visible, if desired, when selecting a mounting location.

When mounting the humidifier on the face of a horizontal return duct or on the face of a vertical return duct, certain conditions must be met to ensure proper unit operation.

- Ensure that the duct surface is reinforced, if necessary, to allow the unit to remain level and plumb.
- Locate the humidifier at least four (4) linear feet upstream of either the furnace fan and/or filter and any turn in the duct. This will ensure that moisture does not accumulate in the duct that may cause leakage, corrosion, or mold growth.
- Mount the humidifier at least six (6) linear feet (preferably 10 feet) upstream of any electronic air cleaner. Failure to follow this recommendation may result in excessive arcing or power supply failure in the air cleaner.
- If the duct seams inside the duct are not flat, locate the humidifier at least three (3) linear feet upstream of the seam.
- If the humidification needs of the space require more than one humidifier, each unit should be installed a minimum of three (3) linear feet apart.
- DO NOT use this humidifier on the discharge or warm air supply side of a forced air heating system. This will reduce the efficiency of the humidifier and may cause additional operational problems.
- DO NOT mount the humidifier in a furnace jacket.
- DO NOT install the humidifier where freezing conditions could occur.
- DO NOT install on gravity hot air systems.

4.2.1 Wall Mounting The Humidifier

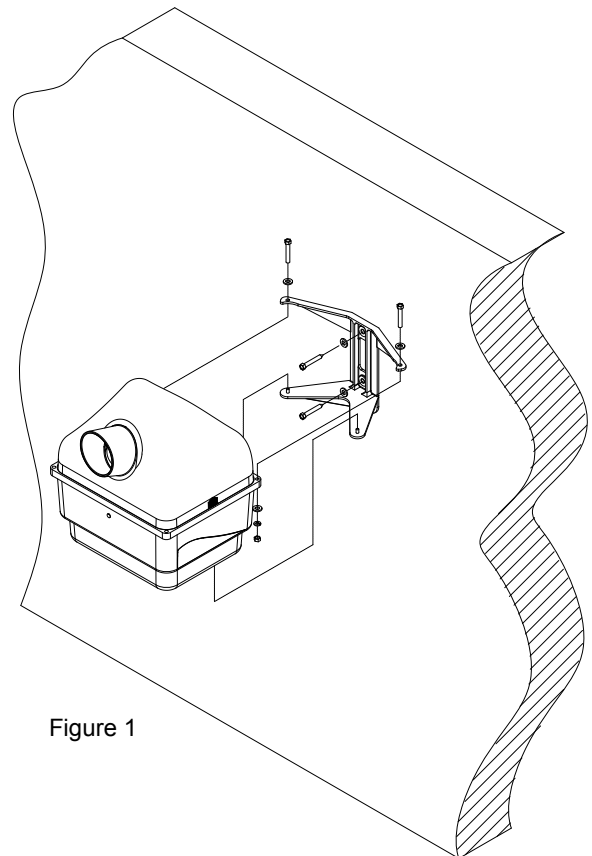

Figure 1

1. Referring to figure 1, using the mounting template, mark the mounting holes on the wall. Ensure that the mounting screws will penetrate wall-studs.
2. While holding the template against the wall, check with a

level to ensure that the unit will be installed level and plumb. If the unit is not level and plumb, ideal operation may not be obtained.

3. Drill the mounting holes as shown on the template for mounting the bracket to the wall.
4. Attached the mounting bracket to the wall using the lag screws provided.
5. Place the base of the unit on the mounting bracket and secure using the screws provided. See Figure #1 for details.
6. Once the humidifier is mounted, place the dome on top of the unit. It will snap into place. Ensure that the direction of discharge is facing away from the wall.
7. Refer to the plumbing and electrical connection sections to complete the installation.

4.2.2 Duct Mounting The Humidifier

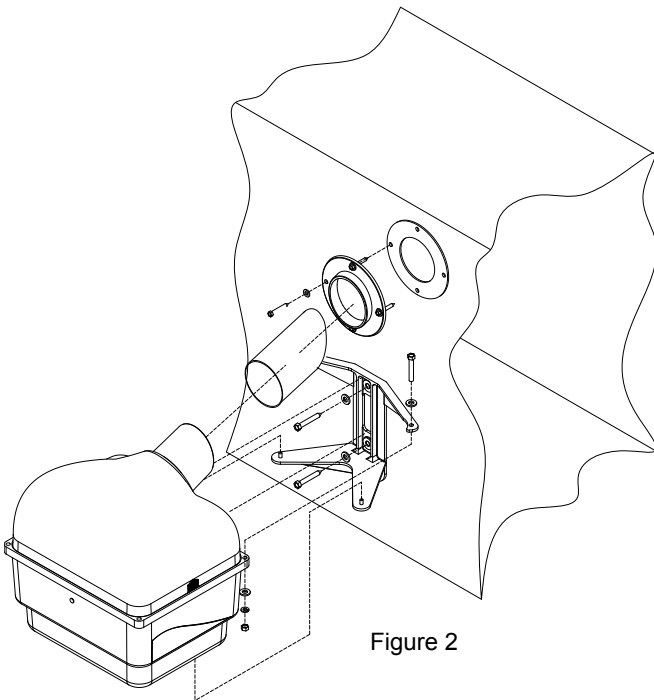

Figure 2

IMPORTANT

The unit must be installed so that interconnection can be made to the source of electrical supply without the use of an extension cord.

1. Referring to figure 2, using the mounting template, mark the mounting holes on the duct. Ensure that the discharge tube is lined up with the centerline of the duct.
2. While holding the template against the duct, check with a level to ensure that the unit will be installed level and plumb. If the unit is not level and plumb, ideal operation may not be obtained.
3. If you are installing the humidifier on a return duct, also mark the discharge hole as indicated on the template.
4. Drill the mounting holes as shown on the template for mounting the bracket to the duct.
5. Cut out the discharge hole while taking care not to injure yourself. Once the hole is cut out, ensure that the edges will not damage the humidifier.
6. Attached the mounting bracket and discharge flange to the wall or duct using the screws provided. Ensure that the

gasket is placed between the duct and the flange.

7. Place the base of the unit on the mounting bracket and secure using the screws provided. See Figure #2 for details.
8. Insert Nozzle Extension Tube through gasket hole in duct approximately 2".
9. With the humidifier mounted, place the dome on top of the unit. It will snap into place. Ensure that the direction of discharge is correct for your application; either wall or duct mount.
10. Insert Nozzle Extension Tube from duct into humidifier dome, discharge nozzle. Tube will insert approximately 1" inside dome discharge nozzle against stops.

4.2.3 Ceiling Mounting The Humidifier

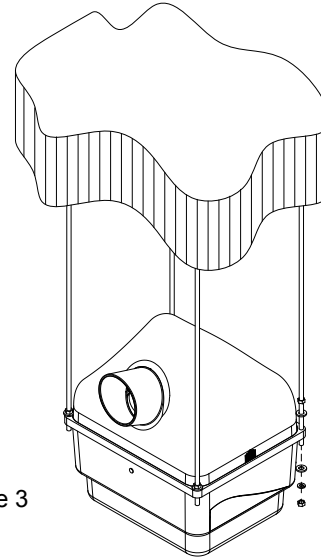

Figure 3

1. Refer to Figure 3. The humidifier base has holes at the four corners that may be used to suspend the unit from the ceiling using threaded rods.
2. Using #10-32 threaded rods, suspend the unit at least 24 inches from the ceiling to prevent mist from impinging on the ceiling.
3. Ensure that the discharge mist is not entrained within air currents that may cause the mist to accumulate on the threaded rods or back onto the unit itself. Dripping may occur.
4. Once the humidifier is mounted, place the dome on top of the unit. It will snap into place. Ensure that the direction of discharge is correct for your application.
5. Refer to the plumbing and electrical sections for completing the installation.

4.2.4 Shelf Mounting The Humidifier

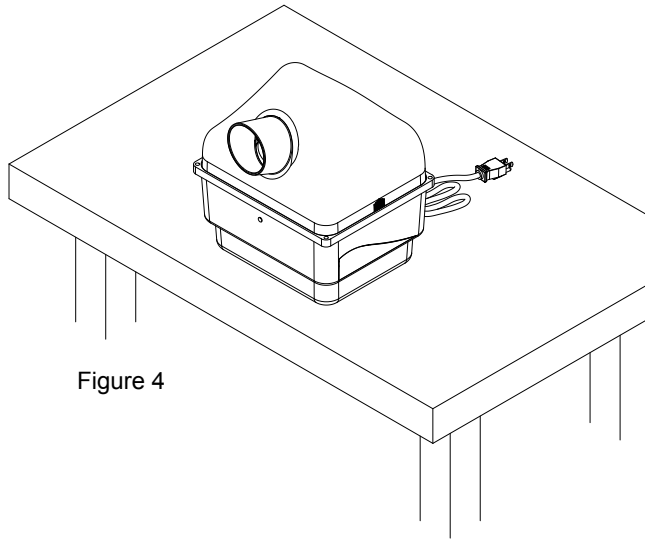

Figure 4

1. The unit may be placed on a shelf for direct space humidification without the use of additional hardware. Rubber mounting feet supplied with the humidifier may be attached to the base of the humidifier.
2. Ensure that the shelf is level and plumb before the unit is placed into operation.
3. See Figure #4 for details.
4. Refer to the plumbing and electrical sections for completing the installation.

4.3 Plumbing (for all installation types)

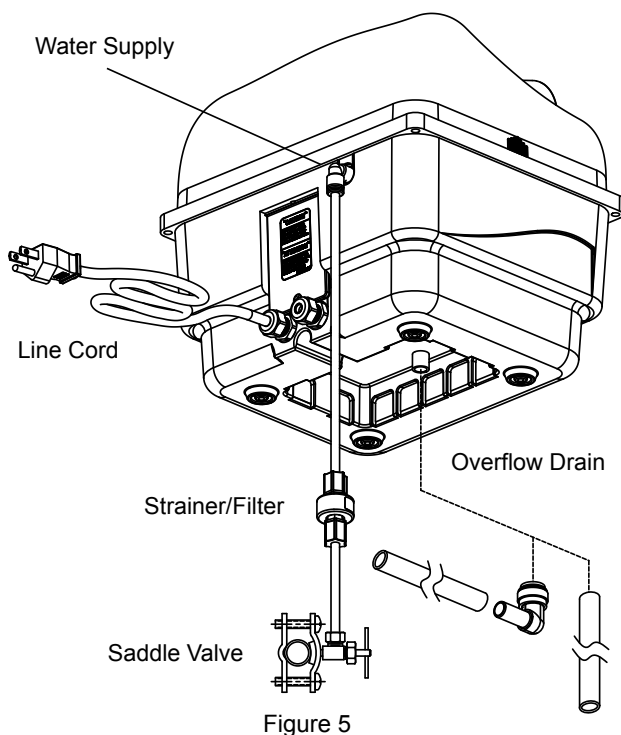

Figure 5

1. Install a saddle valve and minimum 50 Mesh strainer (not provided) on the nearest cold water supply pipe. (See the instructions that accompany the saddle valve for additional

details).

2. After the saddle valve and strainer are installed but before inserting the line into the humidifier supply fitting, turn the saddle valve to the open position and discharge the water into a bucket or pan. This will allow the water to flush any debris that may have accumulated in the line during the installation process. Once this is complete, close the saddle valve.
3. Attach the line to the humidifier by simply pushing the line into the push-to-lock fitting and pulling back slightly to seat the line. If it becomes necessary to remove the line, press on the release ring around where the line goes into the fitting to release the line and pull it out.
4. Connect the drain hose to the overflow fitting and run this to an open, gravity drain. The end of this line must not be submerged in water or be trapped.
5. Turn on the saddle valve.
6. Upon starting the humidifier, you will notice water flowing into the humidifier. If any water discharges from the overflow drain hose, ensure that the unit is level and plumb. If water continues to flow from the overflow, please refer to the troubleshooting chart.

4.4 Electrical (for all installation types)

Removal of electrical cover plate will reveal the connection terminals for the humidistat (all models) and the high voltage terminals (220 VAC models only). See Figures 6 & 6A below.

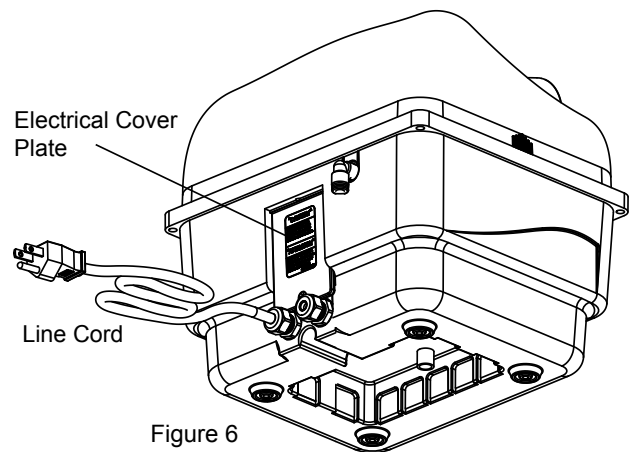

Figure 6

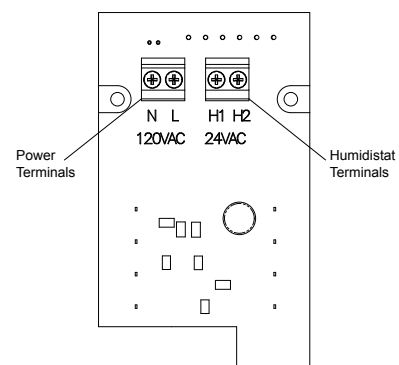

Figure 6A

- US models are factory equipped with a 120 VAC line cord attached to the unit. This must be connected to an electrical outlet that is protected for short-circuit and overload according to national, state and local codes/standards. It is the installers responsibility to ensure compliance with these codes. It is not necessary to operate this unit from a dedicated circuit. See Figure 7.
- UK (CE) models must be wired for 220 VAC from a protected circuit wired in accordance with any applicable codes or standards. It is the responsibility of the installer to ensure compliance with these codes. Disconnection means shall be provided for fixed wiring. See Figure 8.

Wiring Diagrams

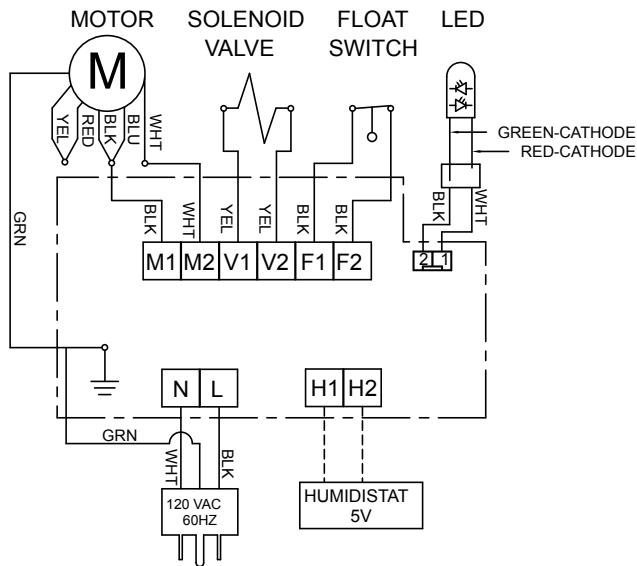

Figure 7
(120 VAC, US VERSION)

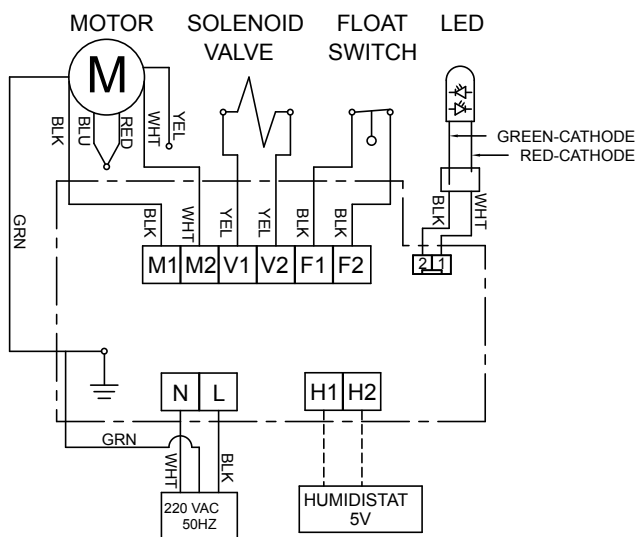

Figure 8
(220 VAC, UK VERSION)

5. Operation

With the CB707 properly mounted it must be determined if the humidifier will be run continuously through the use of jumper between the H1 & H2 terminals on the control board or receive a "call for humidity" from the humidistat provided. Humidistat wiring is shown in the preceding wiring diagrams.

5.1 Preliminary Checkout and Start-up Sequence

1. Check that unit overflow plumbing is properly connected.
2. Ensure that the supply plumbing is installed properly.
3. Open cold water supply and insure water is reaching the unit. Incoming water line must be filtered.
4. Plug unit line cord into appropriate power source or connect power to the unit supply terminals.
5. With the power on and the humidifier set to run continuously or if the humidistat has a "call for humidity", the indicator LED will illuminate Green and the unit will discharge a fine mist. If this is the initial startup the unit will take approximately 60 seconds before producing the fine mist. Mist will be discharged immediately on subsequent running conditions. If the unit has been idle for a prolonged period of time such as the off season - summer months, restart will again take approximately 60 seconds to produce mist.
6. If at any point the indicator LED illuminates Red a fault has been detected; service may be required and the fault must be reset. Refer to the Maintenance & Troubleshooting section.
7. Refer to the humidistat manual for "call for humidity" set-point information.

5.2 Starting/Stopping the unit

In order to start the unit it is necessary to close the H1 & H2 terminals on the circuit board. This may be accomplished by installing the included humidistat or by installing a jumper wire between the "H" terminals on the control board. In order to stop the unit you must only lower the humidistat setting to a point at which the contacts are open. If the unit is set up for continuous operation by installing a jumper between the "H" terminals on the control board, you must remove the jumper wire placed between terminals H1 & H2 on the control board.

5.3 End of Season Decommissioning

1. At the end of the humidification season it is recommended that the unit be run dry of all remaining water in the reservoir. Please do the following...
2. Close the water supply valve so that water can not flow to the unit.
3. Adjust the humidistat all the way up so that the unit begins to operate. If the unit is dispersing into a duct, ensure that the blower is operating before allowing the unit to operate.
4. The unit will produce mist, but will not be able to replenish the reservoir because the water supply valve is closed.
5. Once the unit stops producing mist, adjust the humidistat down and the unit should stop operating.

6. Maintenance & Troubleshooting

DANGER - RISK OF ELECTRIC SHOCK

Before cleaning, servicing, or parts replacement, the unit must be disconnected from all sources of electricity.

6.1 Cleaning Instructions

It will become necessary to clean your humidifier as time goes on. A red LED Service indicator light may light up. (Refer to #3 in Control Board Faults Section, 1500 hour service interval.) This will tell you that it is time to service your humidifier. Please follow the following procedure.

1. Perform the End-Of-Season Decommissioning procedure described in section 5.3. This will cause the unit to run out of water so that service can be performed without a large amount of water inside the unit.
2. Adjust Humidistat to the lowest setting to ensure that there is no call for humidity.
3. Unplug the humidifier in order to remove power before servicing the unit.
4. Close the water supply valve so that no water may flow to the humidifier and remove the supply line from the push-to-lock fitting. See section 4.3 Step 3 for details regarding removing the tube from the fitting.
5. Remove the top discharge dome and wipe out any accumulated mineral build-up.
6. Examine the atomizing posts and gently clean any mineral build-up from the posts using a soft cloth. Ensure great care is taken not to damage, bend, or break the atomizing posts.
7. Remove the cover from the electrical box and unwire the line cord and humidistat wires from the terminals. It is not necessary to remove the strain relief fittings.
8. On either side of the circuit board there are mounting screws. Remove the screw that secures the ground wire (left). Loosen the screw on the right. It is not necessary to remove it completely. (See Figure 9)
9. With the dome removed from the unit, remove the four screws that secure the motor base to the reservoir base. (See Figure 10)
10. The mid-section of the humidifier may now be lifted from the base. This will allow access to the water reservoir, impeller pump, solenoid valve, float switch, control enclosure and air filter media. The circuit board will slide out with the mid-section of the unit.
11. Examine the float switch and ensure that it moves freely upon the shaft. If there is any binding, gently clean the shaft to allow the float to move freely.
12. Wipe away any additional mineral build-up that may have accumulated elsewhere within the humidifier.
13. Examine filter media and remove and clean as necessary using a mild soap and water solution. Allow to dry and reinstall between vent holes and pinch pins.
14. Reassemble the humidifier in the reverse of disassembly. Assembly may be simplified by turning the humidifier upside-down. This will simplify the alignment of the circuit board with the grooves on either side of the electrical compartment.
15. Reset the service timer (RED LED) by cycling the humidistat on & off three times within 10 seconds. Return to service.

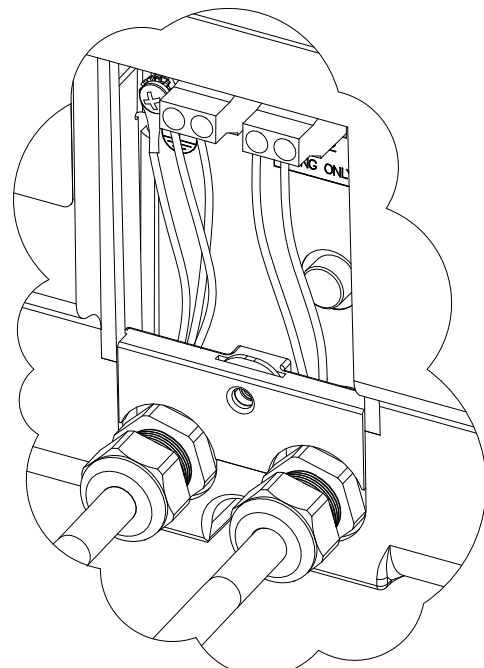

Figure 9

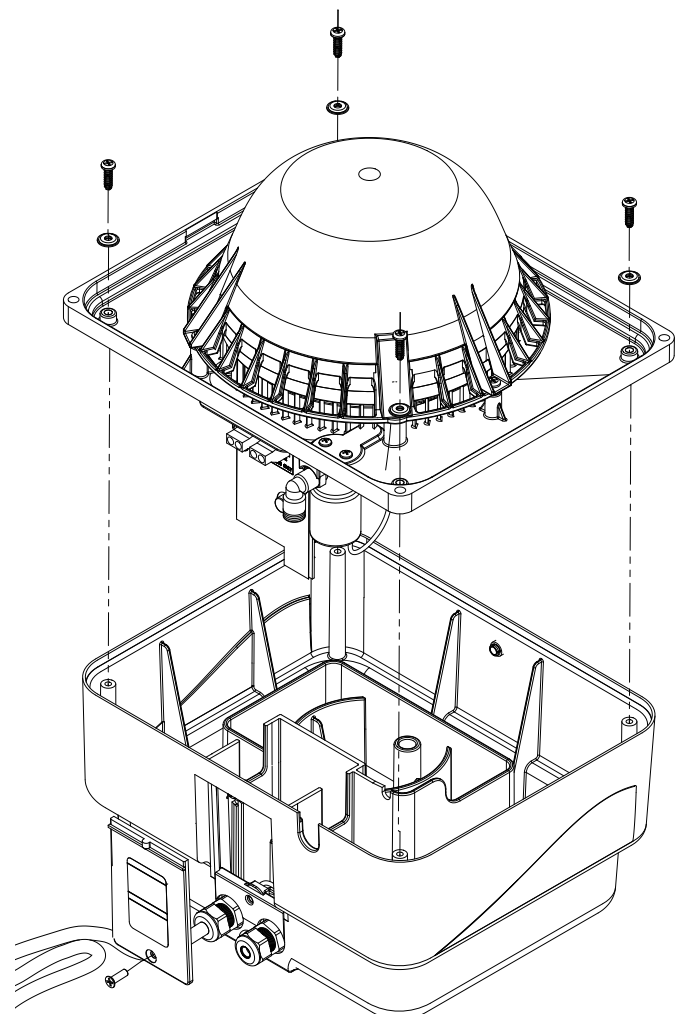

Figure 10

6.2 Control Board Faults & Reset

Faults are indicated by a flashing LED located on the base of the unit opposite the electrical access cover. (See figure11)

1. Red LED, blinking repeatedly .25 second ON & .25 second OFF. Unit will not function.
 - A. Float switch not opening after 10 minutes of fill.
 - a) Damaged or stuck float switch. This would cause overflow to drain.
 - b) Restricted input water flow; clogged solenoid valve or flow restrictor.
 - c) Leaking reservoir.
 - d) Bad control board.
2. Red LED, blinking repeatedly 1 second On & 1 second OFF. Unit will not function.
 - B. Float switch not closing in 30 minutes.
 - a) Damaged or stuck float switch. This would cause reduced mist or dry air discharge.
 - b) Clogged pump or damaged pump/impeller.
 - c) Bad control board.
3. Red LED, solid ON. Unit will continue to function.
 - A) 1,500 service interval on "call for humidity" hours

Control Board Fault Reset

All control board faults are reset by cycling the "call for humidity" signal ON and OFF, 3 times in ten seconds. This may be accomplished by rotating the humidistat knob from the minimum setting to the maximum setting repetitively.

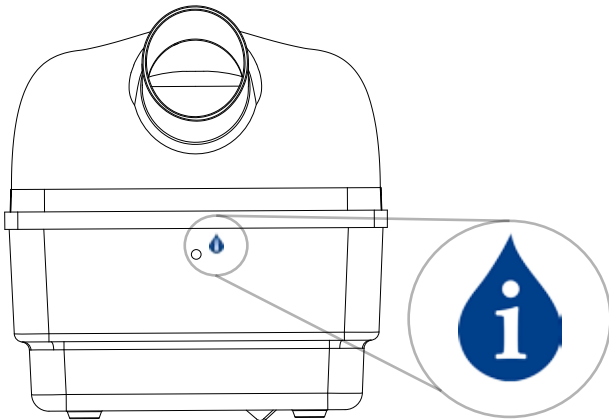

Figure 11

Installation, Operation, & Maintenance Manual

6.3 Troubleshooting Chart

Problem/Symptom	Probable Cause	Corrective Action
Power is applied and the LED does not illuminate.	No issue.	The LED does not illuminate unless the H1 & H2 terminals are closed on the circuit board or the humidistat contacts are closed.
Humidistat contacts are closed but the unit will not produce mist	No water pressure or water supply valve is closed.	Ensure that the supply water is on.
	Solenoid Valve is not operating	Ensure that there is power supplied to the valve. Check control board output.
	Motor is not operating	Ensure that there is power supplied to the motor. Check control board output.
	Circuit Board has failed/fuse is blown	Replace circuit board.
	Duct Static pressure is too high	Ensure unit is connected to the return duct and not the supply duct. Relocate if necessary.
Motor will not operate/turn	Impeller pump broken or missing	Ensure pump has not fallen out of the impeller tube.
	Motor internal thermal protective device is open.	Remove power and allow motor to cool. Restart unit and ensure proper operation. If motor will not turn, replace motor.
	Motor has failed	Replace motor.
LED is glowing solid RED	Impeller is stuck	Remove obstruction or replace motor as necessary.
	Service Timer has expired	Follow the Cleaning instructions and reset the service interval. See page 8.
Unit will not operate and LED is blinking rapidly. (1/4 second interval)	Damaged or stuck float switch	Clean float switch and ensure proper operation. Replace switch is necessary.
	Restricted input water flow; clogged solenoid valve	Inspect orifice located in solenoid valve discharge tube.
	Leaking reservoir	Inspect the unit for cracks in the reservoir. Replace reservoir if necessary.
	Control Board has failed.	Replace control board.
Unit will not operate & LED is blinking slowly (1 second interval)	Damaged or stuck float switch	Clean float switch and ensure proper operation. Replace switch is necessary.
	Clogged pump or damaged pump/impeller	Ensure pump has not fallen out of the impeller tube.
	Bad control board	Replace control board.
	Solenoid Valve stuck open	Replace solenoid valve.

Installation, Operation, & Maintenance Manual

QUANTITY	ITEM NO.	PART NUMBER	DESCRIPTION
1	1	265311-001	UNIT BASE
1	2	265433-001	ENCLOSURE ENTRY BRACKET
1	3	265317-001	COVER PLATE
1	4	265307-001	DIFFUSER/DRAIN BASE (MUST BE ORDERED WITH ITEM 58)
4	5	265559-001	STRAIN RELIEF CONNECTOR W/SEALING NUT
1	6	265308-001	MOTOR BASE
1	7	265309-001	MOTOR COVER
1	8	265443-001	MOTOR MOUNTING PLATE
1	9	265376-001	SHADED POLE MOTOR
1	10	265377-001	FLT015 FLOAT SWITCH
1	11	265304-001	HOOD (NOT SHOWN)
1	12	265303-001	HOOD EXTENSION (NOT SHOWN)
1	13	265479-001	IMPELLER
1	14	120609-003	LOCKWASHER, SPRING, SST #4
4	15	120609-007	LOCKWASHER, SS #10
1	16	120608-005	WASHER, FLAT, SST #4
4	17	120608-009	FLATWASHER, #10 SST
4	18	120608-008	FLATWASHER, #8 SST
1	19	G-109	G-109 SOLENOID VALVE ASSEMBLY
1	20	165001-001	"PUSH-TO-LOCK" MALE ELBOW 1/4" X 1/8 NPT
1	21	265305-001	FILL FITTING, 1/8" NPT
2	22	166129-001	SCREW, #8 X 3/8" PH PH THRD CUT., SST
7	23	265378-220	SCREW, PHIL PH, PLASTITE . #8 x 5/8" LG.
4	24	265378-219	SCREW, PHIL PH, PLASTITE . #8 x 1/2" LG.
1	25	265560-001	RUBBER SEAL PLUG
1	26	8A	PUMP
4	27	4009	GROMMET
1	28	265574-001	5MM LENS (707)
1	29	265577-001	SPC125 SPACER (707)
1	30	265575-001	5MM ROUND LITEPIPE
1	31	265573-001	LED LAMP, RED/GREEN
1	32	265576-001	CNX K CABLE ASSEMBLY (707)
1	35	265612-001	WHITE NWPE FILTER 18.5" (707)
2	36	127258-001	PIGTAIL CONNECTOR
1	37	265627-001	ENCLOSURE GASKET
1	38	265627-002	DOOR GASKET
1	39	265628-001	POWER CORD 6'
1	40	265440-001	CONTROL BOARD (707), 120VAC (SEE NOTE 1 ON PAGE 13)
-	40	265440-002	CONTROL BOARD (707) 220VAC (SEE NOTE 1 ON PAGE 13)
4	41	121078-004	WASHER, SEALING-BARTITE #8
1	42	265582-001	INSULATION BOARD (707)
4	43	265785-001	O-RING
4	44	266199-001	SHOULDER SCREW, #8-32 X 1/4"
1	45	158931-004	CAP SCREW, SOCKET HEAD #4-40 X 3/8

Installation, Operation, & Maintenance Manual

1	46	166260-001	RETAINING RING
2	47	137790-001	SCREW - PH PAN HD, MACH., #6-32 X 1/4"
2	48	120032-002	EXT TOOTH LOCKWASHER, #6
1	49	142854-206S	SCREW, PHIL FH MACH S/S, #8-32 x 1/2
1	50	121800-004	NUT-LOCKWASHER, #8-32
1	51	121800-003	NUT-LOCKWASHER, #6-32
1	52	146548-047	SCREW, PAN HD MACH PHIL S/S, #8-32 X 1/2"
1	53	266152-002	NOZZLE EXTENSION TUBE (NOT SHOWN)
2	54	266793-001	FEMALE THREADED STANDOFF
1	55	266455-001	CONTROL BOARD BRACKET, RH
1	56	266455-002	CONTROL BOARD BRACKET, LH
2	57	266792-001	LOCKNUT, PG9
1	58	266826-001	INLET RING
1	59	265442-001	GROUND PLATE ASS'Y
2	60	265627-003	ENCLOSURE GASKET
4	61	265038-004	SPACER, ALUM. - 0.25 OD x 0.166 ID x 0.19 LG
4	62	137245-004	NUT-LOCKWASHER - SST, #8-32
1	67	265310-001	WALL MOUNTING BRACKET (707) (NOT SHOWN)
1	68	265160-001	HUMIDISTAT (NOT SHOWN)

Note 1: 220 VAC units use control board (item 40) part number 265440-002 only.

Note 2: If replacing item 4 (Diffuser/Drain Base), also order item 58 (Inlet Ring). Item 58 must be affixed to Item 4 using clear silicone multi-purpose RTV.

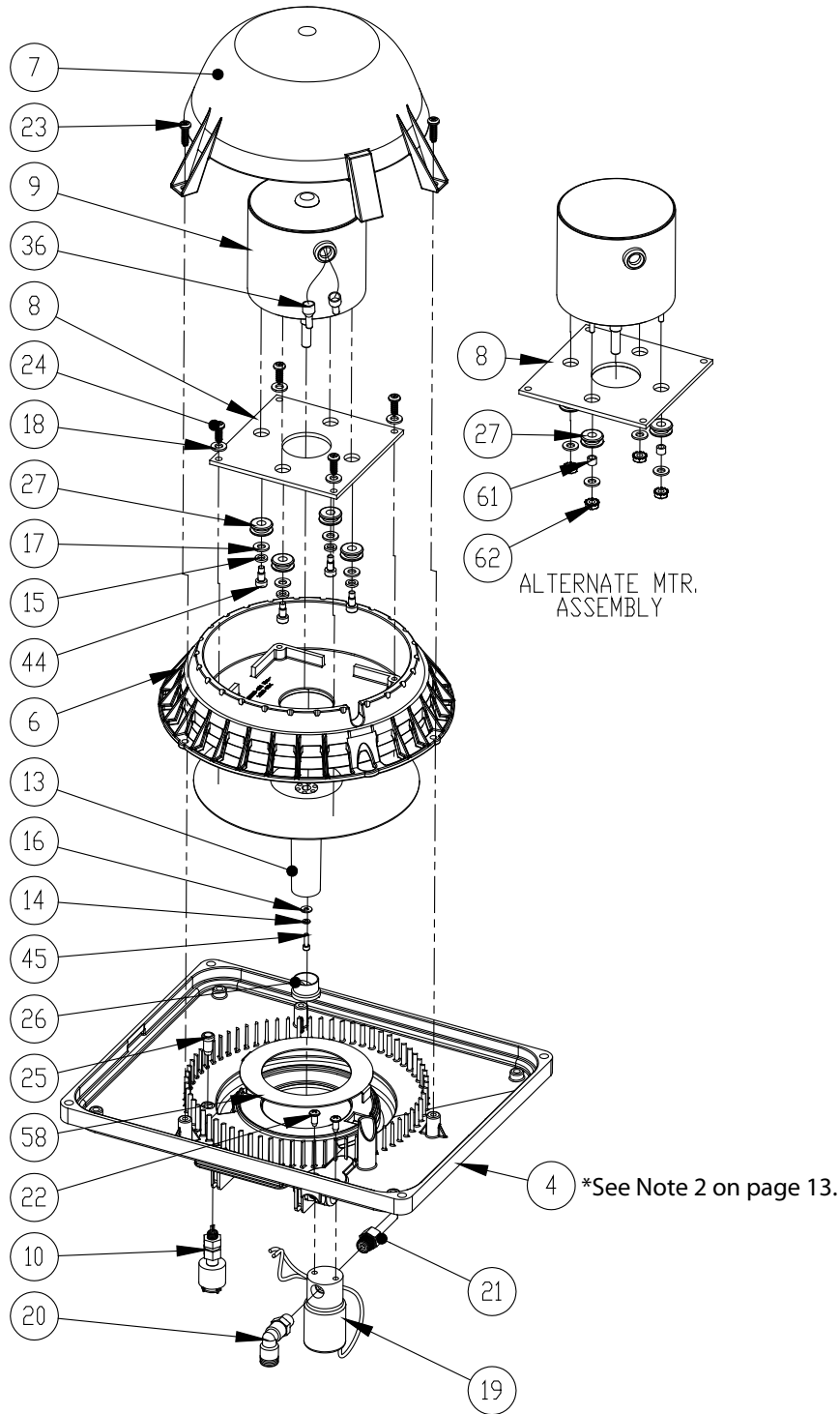

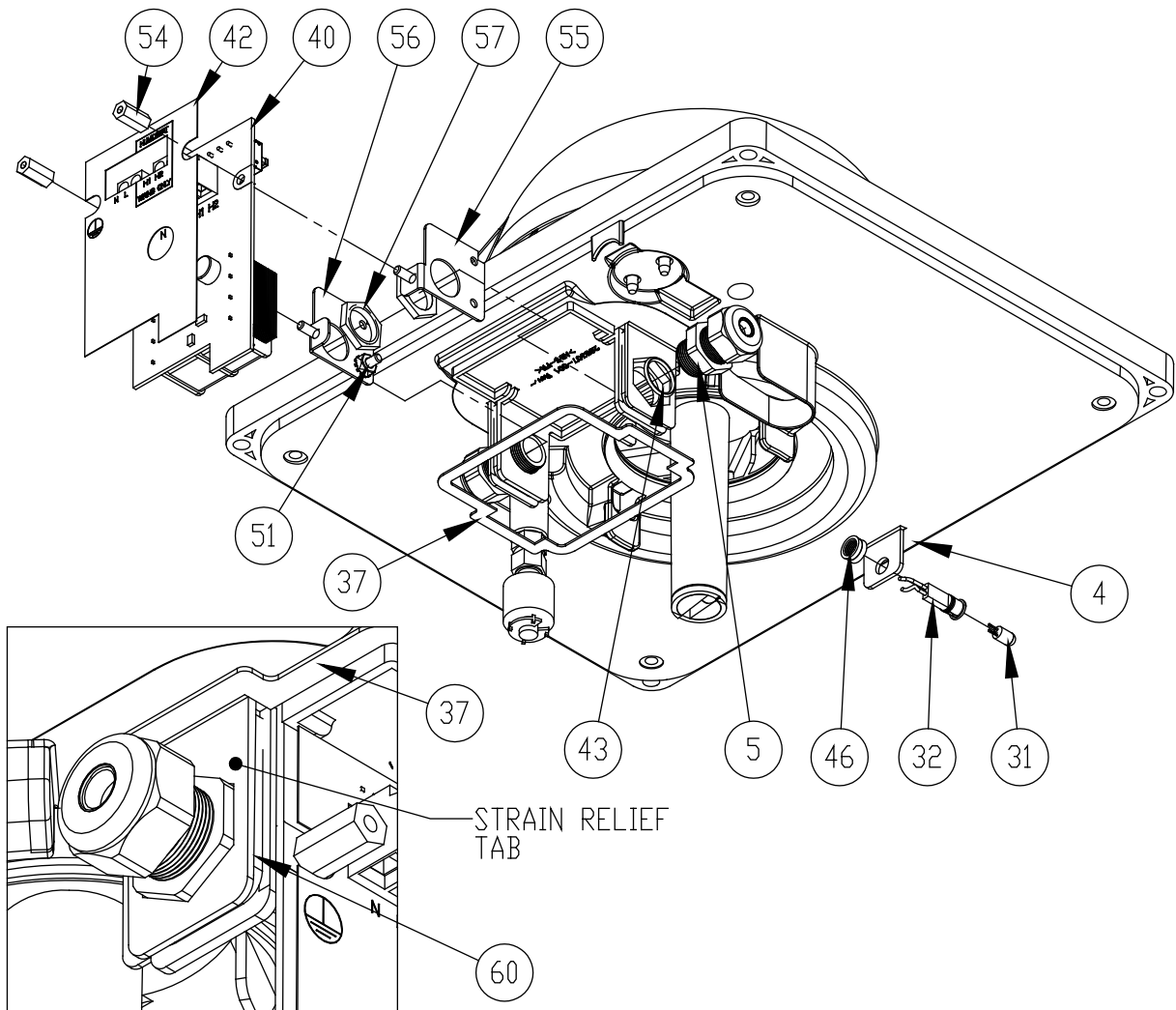

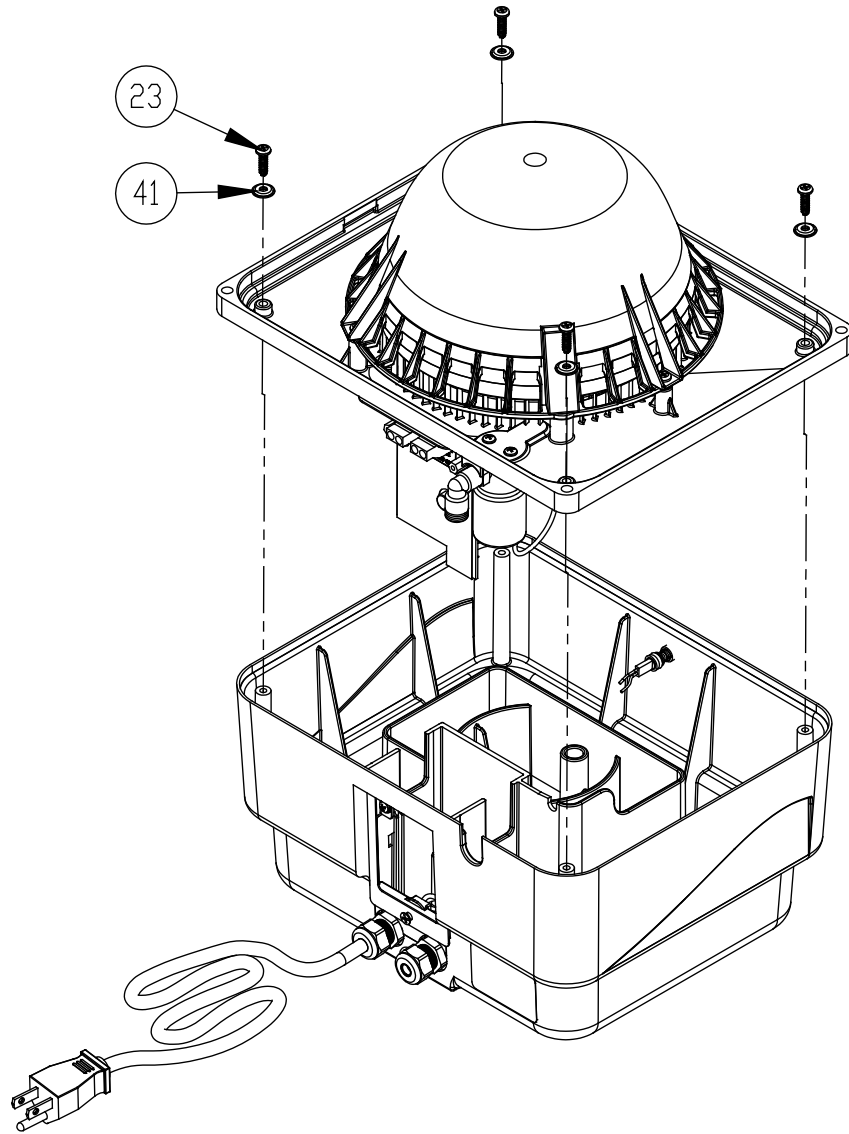

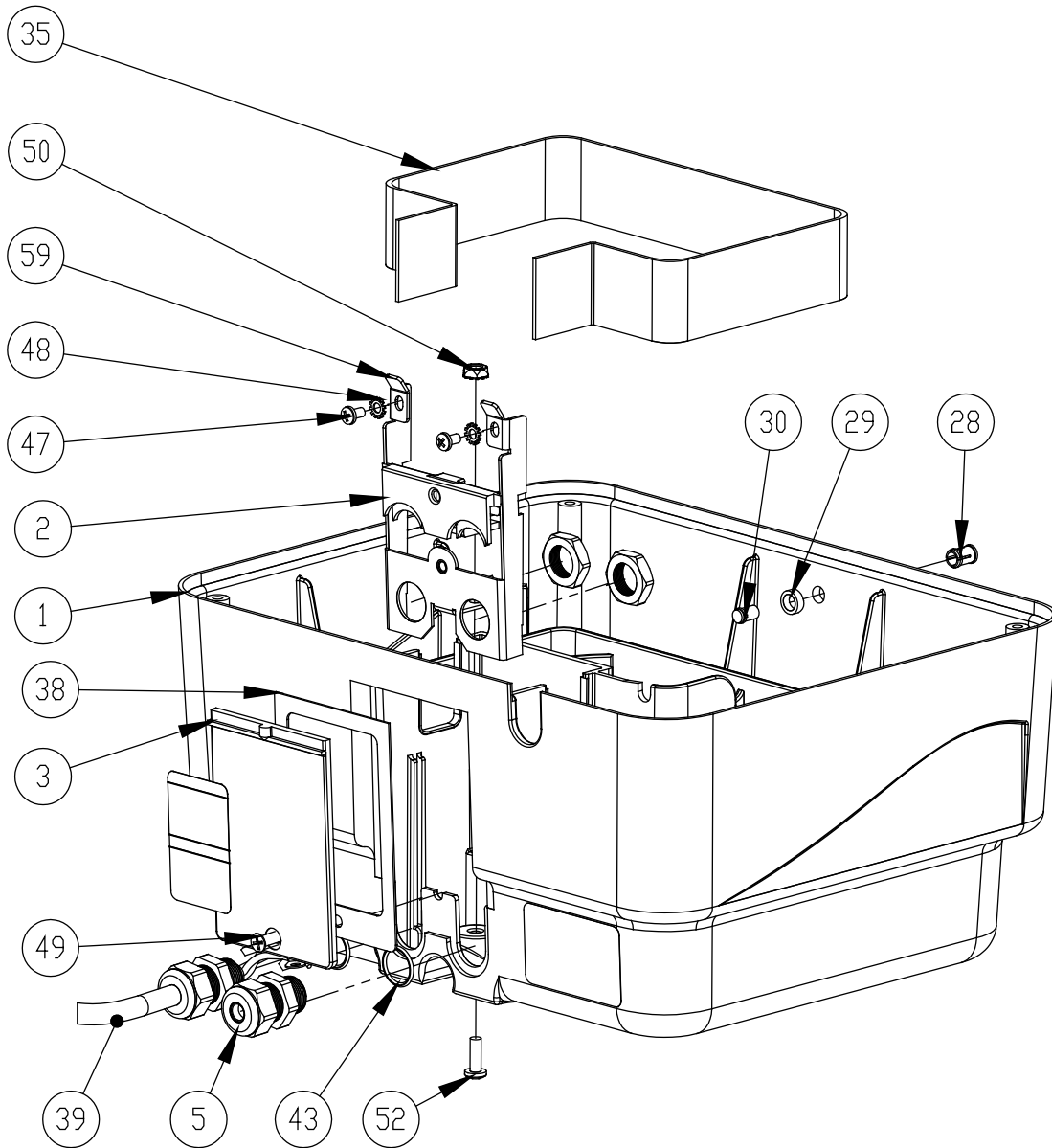



TRION[®]
Air Purification Systems

Trion[®]

101 McNeill Rd. | Sanford, NC 27330

P: 800.884.0002 | F: 800.458.2379 | www.trioniaq.com | customerservice@trioniaq.com
