



Whole House Central Dehumidifier

Comfort-D™

Models: D75 and D95

Table of Contents

Introduction.....	2
Contents	2
Unit Dimensions	3
Specifications	4
Unit Location.....	5
Install Location.....	6-7
Ducting	8
Wiring	9-11
Electrical Requirements.....	12
Condensate Removal.....	12
Operation.....	13-14
Maintenance.....	14
Parts Diagram.....	15
Warranty	16

Please complete the following on the day of the installation.
Homeowner to retain for their future informational purposes.

Unit Model Number _____

Serial Number _____

Installation Date _____

Installing Contractor Name _____

Installing Contractor Phone _____

Introduction

Caution: Read the entire manual carefully and completely before installing this product. Installation and maintenance should be completed by qualified personnel. Installation contrary to these guidelines may void warranty.

The benefits of a properly humidified environment are many. They include personal comfort as well as the preservation of furniture, draperies, carpets, wooden floors and cabinets, paintings, pianos, etc. Higher humidity levels can also increase the growth-rate of mold, bacteria, viruses, and even dust mites in the home. Your home can be more comfortable at a warmer temperature with drier air than without controlling humidity during the humid summer months. Since every degree of temperature change represents about 3% to 5% of the total cooling costs, each degree warmer you can set the thermostat can represent a significant annual savings.

During the cooling season, warm, moist air infiltrates the home and must be cooled. When cooled, this air can still be humid as air conditioners are designed to cool the air, not dehumidify the air. A small amount of dehumidification may be a benefit of air conditioners, but they actually work harder and longer to cool the air when the air is moist. Only by using a whole house dehumidifier to reduce the humidity in the entire home's air, can a balance between humidity levels, temperature, comfort, and energy costs be optimized.

Contents

The following items should be included with your Trion Comfort-D Dehumidifier.

- Comfort-D75 or Comfort-D95 Dehumidifier
- Installation/Operation Manual
- Condensate Drain Trap
- (4) Adjustable Support Legs

If any items are not found, please contact Trion Customer Service at 800-884-0002 to acquire replacements.

The following are a list of items that may be required for a complete installation:

- 8 inch (D75) or 10 inch (D95) flexible duct to isolate vibrations from return duct.
- Ducting (Length and size based on type of installation and unit size.
See pages 6-7 of manual for installation types.)
- Remote Humidistat
- Condensate Pump
- 8 inch (D75) or 10 inch (D95) "take offs" for connection to HVAC duct work
- ¾" PVC pipe and fittings for completion of drain to pump, outside space, or code approved service drain
- Level (unit must be level or slightly tilted toward drain outlet to drain properly)
- 18-20 gauge thermostat wire

Unit Dimensions

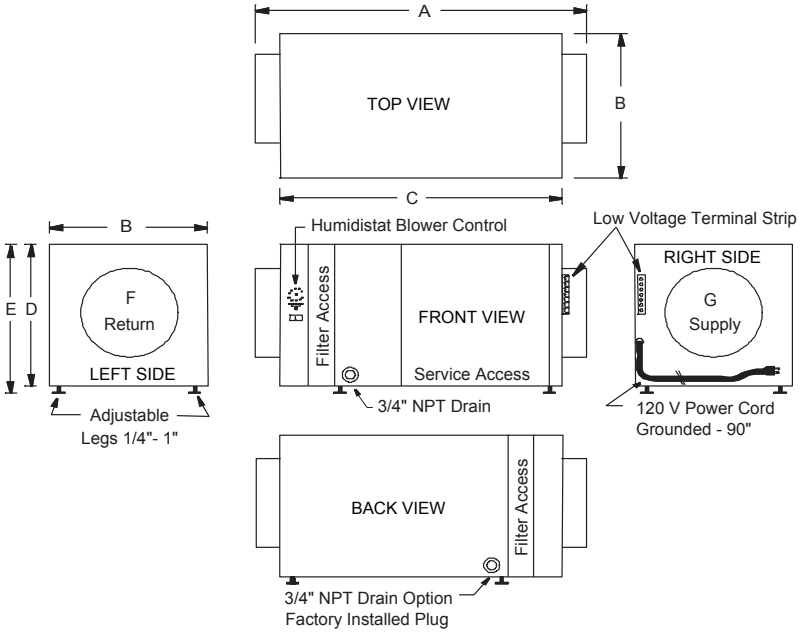

Dimension Table		
	Comfort-D75	Comfort-D95
A	27.25 inch	29.25 inch
B	13.00 inch	14.25 inch
C	23.25 inch	25.25 inch
D	12.75 inch	14.25 inch
E	13.75 inch	15.25 inch
F	8.00 inch dia.	10.00 inch dia.
G	8.00 inch dia.	10.00 inch dia.

Specifications

Model	D75	D95
Capacity(@80°F,60% RH)	74 Pints/Day	95 Pints/Day
Temperature Range	50-95°F	50-95°F
Volts/Hertz	120V, 60Hz	120V, 60Hz
FLA (@80°F, 60% RH)	6.7 Amps	10.8 Amps
LRA (@80°F, 60% RH)	46.5 Amps	59.0 Amps
Inlet Diameter	8 inch round	10 inch round
Outlet Diameter	8 inch round	10 inch round
Unit Dims. (LxWxH)	27.25"x13.00"x12.75"	29.25"x14.25"x14.25"
Filter Dims (LxWxH)	11.75"x11.75"x2.00"	13.75"x13.75"x2.00"
Filter Efficiency	MERV 11	MERV 11
Compressor Size	5/8 HP	3/4 HP
Fan Motor Size	90 W	115 W
Airflow@0.0 inch H2O esp	280 CFM	375 CFM
Airflow@0.3 inch H2O esp	235 CFM	295 CFM
Airflow@0.5 inch H2O esp	195 CFM	235 CFM
Refrigerant	R-410A	R-410A
Refrigerant Amount	17.5 oz	16.0 oz
Weight (Shipping Weight)	65 lbs (80 lbs)	90 lbs (105 lbs)
Energy Star Rated	Yes	No
ETL (USA & Canada)	ANSI/UL STD 474, Applicable Sections of ANSI/UL STD 1995, CAN/CSA STD. C22.2 No.-92-197	

Unit Location

The Comfort-D can be installed in a variety of locations to meet the owner's needs as listed below. In all cases keep the following cautions in mind:

1. The unit is designed to be installed indoors in a space that is protected from rain, flooding and/or other forms of excess water. Unit is not designed to be exposed to chlorinated pool conditions or spaces where unit will be exposed to corrosive chemicals or conditions.
2. Install the unit with space to access the front panel for maintenance and service. Also allow easy access to the filter cover panel. **DO NOT INSTALL UNIT WITH THE FRONT PANEL OR FILTER COVER PANEL INACCESSIBLE.**
3. Avoid discharging the air directly at people, over the water in pool areas, or other areas or objects where dehydration or evaporation of moisture is not desired.
4. If used near wet areas, be certain there is NO chance the unit could fall into the water or be splashed and that it is wired into a GROUND FAULT INTERRUPTER protected circuit.
5. A secondary drain pan **MUST** be placed under the unit if installed above a living area or above an area where water leakage could cause damage (see local codes for other requirements)
6. **DO NOT** position the Comfort-D directly on structural members where noise or vibration may be objectionable. The unit is equipped with adjustable support feet to raise and level the unit from the mounting surface, these adjustable feet should be utilized to provide improved drainage from the drain pan and should be adjusted to tilt slightly toward the drain utilized.
7. The Comfort-D should be located near the existing air handling system to minimize the required ductwork for connecting of the Comfort-D to the existing air handling system. When the remote control option is used, the control (humidistat) unit must be located in the space that is to be conditioned. The control (humidistat) may be low voltage (24 volt) and should be connected to the Comfort-D with code approved, low voltage thermostat cable.
8. When locating the Comfort-D in areas of extreme heat or high humidity, >120-degrees/90% humidity, additional external insulation may be required to prevent undesired condensation on the exterior of the unit.

Install Location

Comfort-D Dehumidifiers are designed for installing as a Whole House Dehumidifier, but in some instances, Spot Dehumidification may be necessary. See below for the type of installation that best fits the situation:

Whole Home Dehumidifier Installations:

In a Basement or Crawl Space with an Existing Forced Air HVAC System

If the structure in which the Comfort-D System is to be installed has an existing forced air HVAC system, utilize the HVAC system to make the Comfort-D System installation easier and provide better system performance.

Basement or Crawl Space Installation: Install a separate 8" (D75) or 10" (D95) return for the Comfort-D in a central area of the structure or if the return ducting is adequate tap into the existing return duct system near the return air grill. Duct the supply of the Comfort-D System to the return ducting of the existing HVAC system. (See diagram on next page.) The fan interlock provision must be utilized for proper system performance.

In an Attic with an Existing Forced Air HVAC System

ALWAYS install a secondary drain pan with a drain or float interrupt for condensation under the Comfort-D in an attic to prevent condensate overflow that may drip down, damaging the ceiling or living space below.

Install a separate 8" (D-75) or 10" (D-95) return for the Comfort-D in a central area of the structure or if the return ducting is adequate, tap into the existing return duct system near the return air grill. Duct the supply of the Comfort-D System to the return ducting of the existing HVAC system. The fan interlock provision must be utilized for proper system performance.

Installation in a Structure with Two Forced Air HVAC Systems

Attach the Comfort-D return to an independent return from the upper level. Attach the Comfort-D supply to the return of the basement HVAC system. This will promote circulation of air through the whole structure from the upper level to the lower level through the Comfort-D. If the Comfort-D is not connected to both HVAC systems, it may not control the humidity of the entire structure. The fan interlock provision should be connected to the lower, ducted, HVAC system and must be utilized for proper system performance.

Installation in a Structure with No Existing Forced Air HVAC System

When installing the Comfort-D in a structure that does not have a forced air HVAC system, a single return for the Comfort-D should be installed in central open area of the structure. DO NOT locate the return in a bathroom or a kitchen. The supply of the Comfort-D should be located in the remote areas of the structure (such as bedrooms, den, etc...). By ducting this way, the air inside the structure will circulate through the Comfort-D to be filtered and dehumidified. 5" (D75) or 6" (D95) diameter duct is recommended for branches to the bedrooms, 6" (D75) or 8" (D95) diameter duct is recommended for branches to larger areas.

Install Location

Spot Dehumidifier Installations:

Installation in a Sealed Crawl Space or Sealed Attic

When installing the Comfort-D in a sealed crawlspace or sealed attic, a single return for the Comfort-D should be installed in the central open area of the structure. If the area is open without partitions, return ducting is not necessary. Supply ducting is recommended to enhance the performance of the system, a minimum length of supply duct, 3' to 6' will aid in air distribution. If the area(s) being served are divided by walls or partitions, a supply and return duct system is recommended.

In all cases, sound duct design practices must be followed such as those provided in ACCA Manual "D", or ASHRAE's "Fundamentals of Air System Design".

Typical Installation Diagram

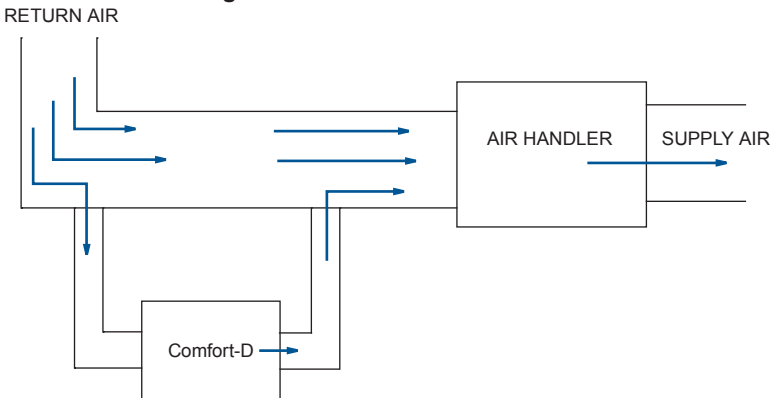

Ducting

Installing Duct

The Comfort-D is equipped with either an 8" (D75) or 10" (D95) round duct collar inlet, and an 8" (D75) or 10" (D95) round exhaust/supply collar that provides for connecting to the supply distribution system. In all cases sound duct design practices must be followed such as those provided in ACCA manual "D", or ASHRAE's "Fundamentals of Air System design".

Ducting for Dehumidification

For the ideal installation, draw air from the central part of the home and return it to the isolated areas of the home like the bedrooms, den, utility room, or family room. The ductwork of the existing HVAC system can be used to supply air to the home. If the existing supply duct adequately serves all areas of the home, discharge the supply air of the Comfort-D into the return of the existing HVAC system where it can be distributed throughout the space. The existing return duct, if adequate, may be used as return for the Comfort-D. DO NOT draw air directly from the kitchen, laundry, or isolated basement. You may draw air from a basement that is open to the home. All flexible ducting connected to the Comfort-D should be approved by local codes and in most cases insulated.

Return air ducts should be designed to allow unimpeded air flow to the return side of the system. For returns less than 10 feet in length, an 8" (D75) or 10" (D95) round or equal may be utilized. Multiple returns are acceptable.

The supply air outlet and the return air inlet are located on each end of the Comfort-D. A length of acoustical flex ducting on the outlet of the Comfort-D will reduce air noise from the fan. A length of flexible ducting on all Comfort-D duct connections is recommended to reduce noise and vibration transmitted to rigid ductwork in the structure.

Ducting the Comfort-D as mentioned in the "Ducting" sections requires consideration of the following points:

Duct Sizing: For total duct lengths up to 10', use a minimum 8" (D75) or 10" (D95) diameter round or equivalent rectangular. For longer lengths, up to 25', use a minimum 10" (D75) or 12" (D95) diameter or equivalent duct size. Grills or diffusers utilized must not excessively restrict airflow.

Isolated Areas: Effective dehumidification may require that ducting be branched to isolated, stagnant areas. Use 8" (D75) or 10" (D95) or larger diameter branch ducting to each of two or three areas, use 6" or larger to each of four or more areas.

Connecting to Existing HVAC Systems: For proper operation, connecting to existing air handler and duct systems requires the fans of each system to be interlocked utilizing the low voltage interlock method provided in the Comfort-D low voltage connection diagram. Refer to low voltage connection diagram in this document and on the unit.

Wiring

Comfort-D Wire Diagram

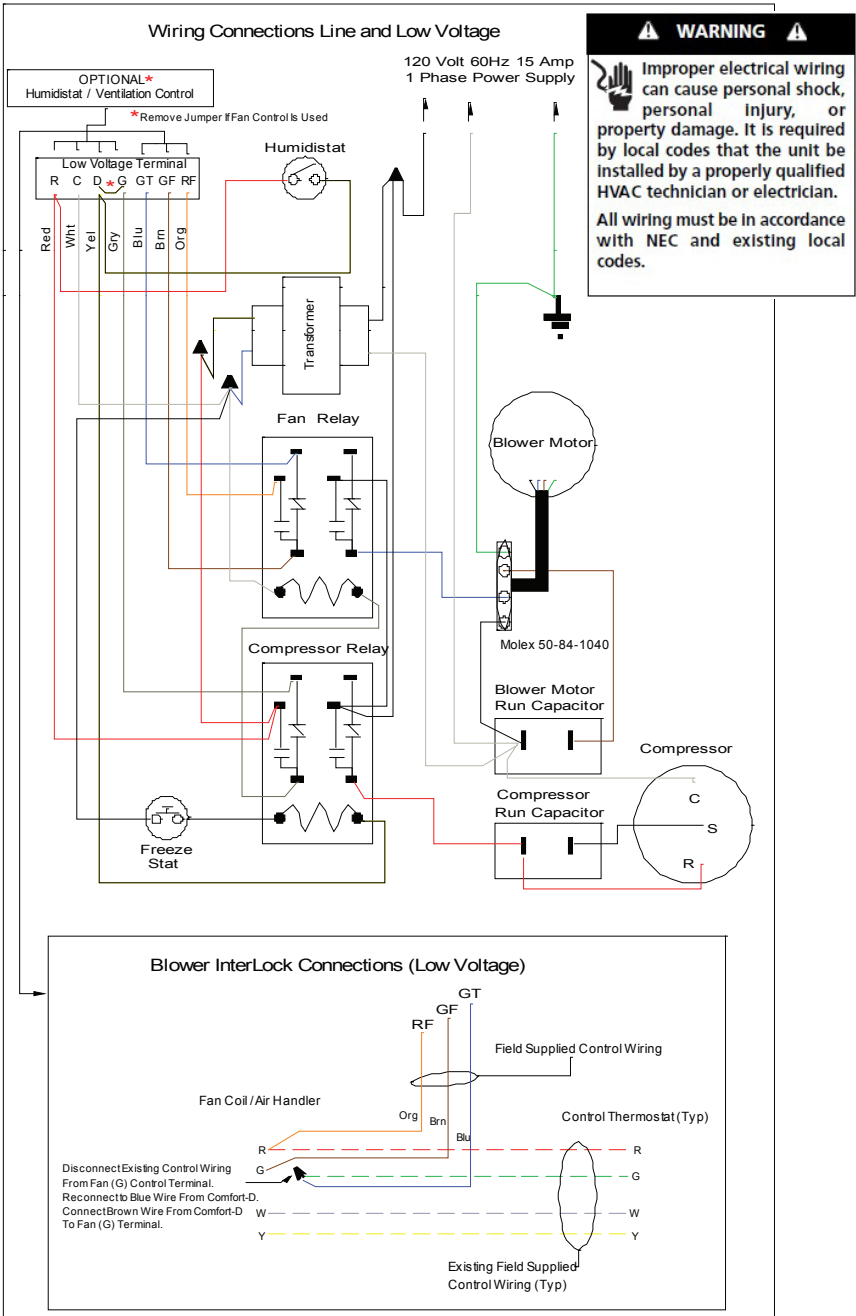

Wiring

Wire Diagram - With Humidistat

Trion Humidistat / Fan Control

Low Voltage Terminal

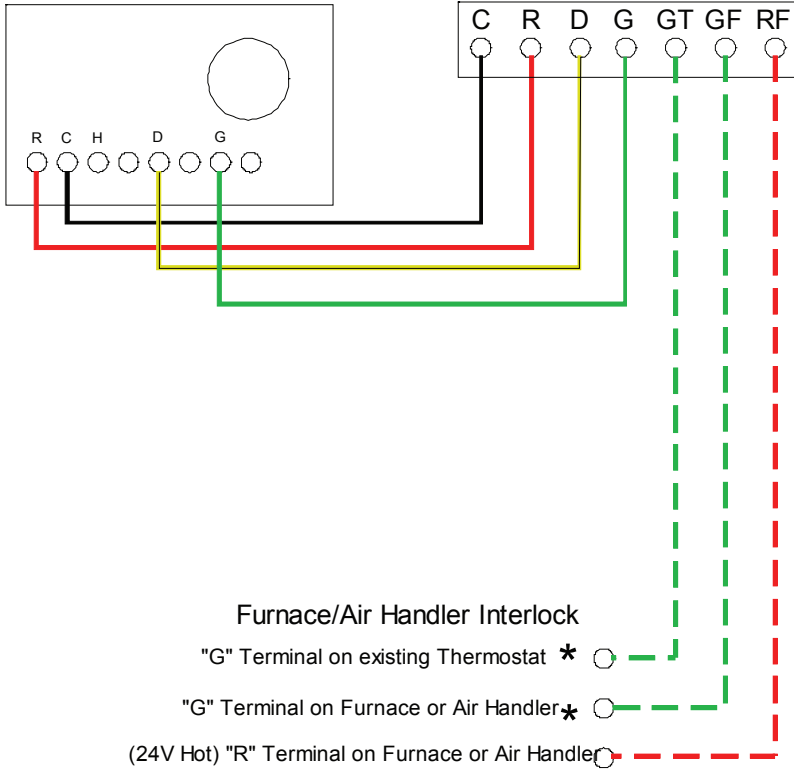

* Remove Existing Wire Between T-stat "G" and AH/Furnace "G"

Wiring

Wire Diagram - With Humidistat and Humidifier

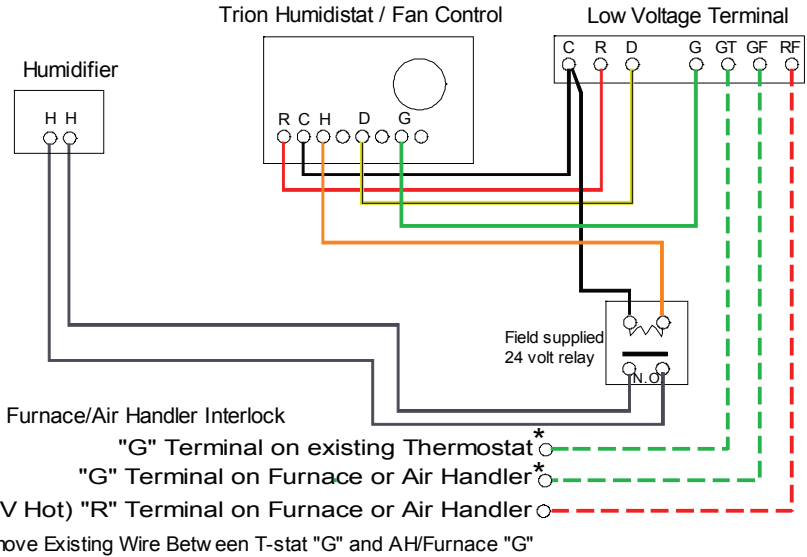

Wire Diagram - Field Connections

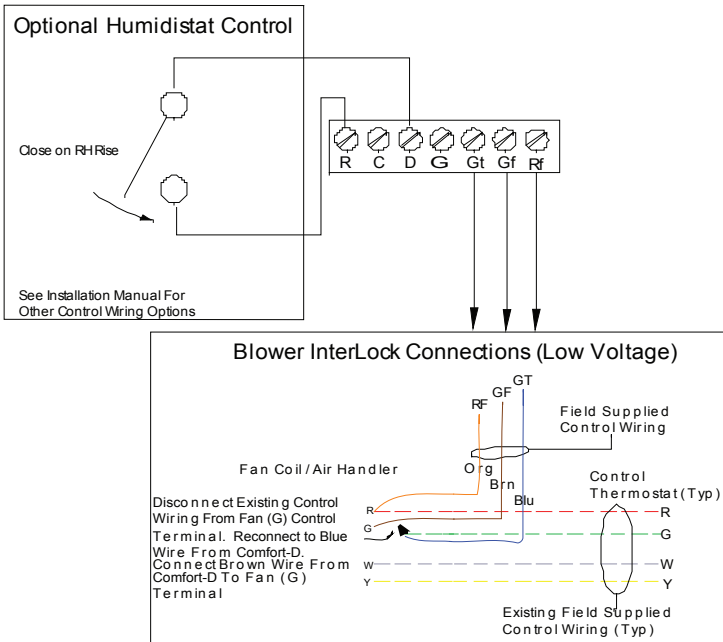

Electricals

Electrical Requirements:

The Comfort-D is equipped with an appliance cord and may be plugged directly into a 120 volt, 15 amp household type convenience outlet. If used in a wet area such as an indoor pool, spa room, or an area prone to flooding (basement or crawlspace), a ground fault interrupter protected circuit is required. In all cases local codes precede over all installation and wiring recommendations.

If a remote wall mounted Humidistat is utilized, install the Humidistat control in a central area of the structure where it will sense the relative humidity of the structure accurately. Do not install the control where it may not accurately sense the relative humidity: near HVAC supply registers, near exterior doors, or near a pool or spa. Do not install the control in an area not served by the Comfort-D. The installer must supply the wiring between the Comfort-D and the Humidistat control. Be sure to safely route the control wiring to prevent damage during installation. Be careful not to cross the wires when connecting the Comfort-D and the control, or damage to the transformer may result.

When a remote Humidistat is utilized, set the unit mounted humidistat to the "OFF" position.

Consult the electrical schematic in this manual or on the access panel of the Comfort-D before making the control connections.

Condensate

Condensate Removal:

Condensate drains by gravity, via the $\frac{3}{4}$ " PVC drain outlet located at two locations, front side and back side. Use of both is not required. As shipped the rear drain is plugged, and may be removed and placed into the front drain outlet if the rear outlet is used. Also included with the unit is the condensate drain trap. This trap must be used to allow the unit to drain properly during operation and prevent air from being drawn from the area where the unit is located. A condensate pump kit (by others) may be required if a lift is necessary to dispose of the condensate. If a condensate pump is used, the condensate trap is still necessary and must be installed between the unit and pump. When the condensate drain is located in, or passes through, a non-conditioned space, the condensate piping should be insulated to prevent sweating, which may cause damage. Double trapping should be avoided and will cause drainage problems if encountered.

Operation

Operation:

The Comfort-D is designed to deliver dehumidified, filtered air to the living space, and is equipped with an onboard humidistat and fan control and can be equipped with various accessories to enhance its operation, including a remote humidistat, and your system may incorporate any or all of the described operational components.

It is recommended that the indoor environment maintain a maximum relative humidity level of 50% to 60%. Other factors may dictate a relative humidity level different than the recommended, such as musical instruments, antiques, books/papers, or special situations. Winter minimum humidity levels of 30-35% may not be attainable without supplemental humidification (Humidifier), and may not be desired during times of low outdoor temperatures.

System Variations:

Humidity Control - Standard:

The system may be installed as free standing or incorporate ducting to an area or existing heating/cooling system. Control is provided by Humidistat with a dial stem type adjustment built into the unit. Set the desired humidity set point by turning the dial stem flat to the corresponding set point indicated on the face of the unit. This humidity control unit will operate the compressor and circulation fan when the dehumidification system is activated, working only when there is a call, or demand for dehumidification.

Remote Humidity Control (Wall Mounted):

When a remote Humidistat is utilized, set the unit mounted humidistat to the "OFF" position.

This control provides the same control functions as above but with greater precision and can be located in the space for easier access, and may include additional features. Available as an accessory item these controls may have different features; refer to instructions included with the control.

Typical system operation sequence:

Upon the relative humidity exceeding the humidistat set point, normally by approximately 3%, the humidistat will energize the dehumidification and air circulation components of the Comfort-D. If the Comfort-D system is connected and interlocked with an existing Heating/Air Conditioning system, this system's circulation fan will also be energized. The Comfort-D will continue to operate until the humidity level is reduced to the set point selected on the humidistat and then will cycle off. During this cycle, the air circulated through the Comfort-D system will be filtered and dehumidified. If an outside ventilation air duct has been installed, fresh air will be filtered and dehumidified and introduced to the space during this cycle.

Operation

Coil Freeze Protection (Auto Defrost):

The dehumidification coil (evaporator) is equipped with a low temperature freeze thermostat; if the coil temperature is reduced to the point of ice buildup, this thermostat will open the compressor control circuit while allowing the fan to continue running. Once the coil has returned to normal conditions the control will close and allow the compressor to re-start. The prevailing conditions of the return air, temperature and humidity, will determine the length of this cycle.

Maintenance

High Efficiency Air Filter:

The Comfort-D is supplied with a 2" pleated high efficiency air filter. The 2" filter is rated MERV 11, and is more efficient than standard air filters and is able to catch much smaller particles that can aggravate allergies. Operating the unit with a dirty filter will reduce dehumidifier capacity and efficiency and may cause the compressor to cycle off and on unnecessarily. Under normal operating conditions, the filter will last approximately 6 months. However, in high particulate concentrations more frequent replacements may be required. It is recommended that the filter be inspected regularly for the first three to four months to determine the loading and correct replacement intervals. Your installation contractor should be contacted for assistance.

To access the air filter, remove the filter access panel from the Front or Back side of the unit, marked "Filter Access". The filter should be readily visible and can be removed by pulling it straight out of the unit.

Replacement filters can be purchased from your installation contractor or ordered from the factory if a local representative is not available. DO NOT operate the unit without the filter, or with a less effective filter than originally supplied. The heat exchange coils inside the unit could become clogged and require disassembly to clean. FAILURE TO MAINTAIN SERVICE AND CLEAN FILTERS WILL VOID WARRANTY.

Oiling & Lubrication:

The fan motor is factory lubricated and sealed, and no further oiling is required. There are no other components requiring the addition of lubricants.

Optional Fresh Air Ventilation (OSA):

If your system includes the optional fresh air system, it will have an outside air intake. Check and clean the screen on the outdoor fresh air intake seasonally. The intake screen must remain clear of any debris that could restrict airflow into the system. This intake should never be located where undesirable fumes, gases or odors may be taken up by the intake. In all cases local codes prevail as to the location of fresh air intakes.

Unit Diagram

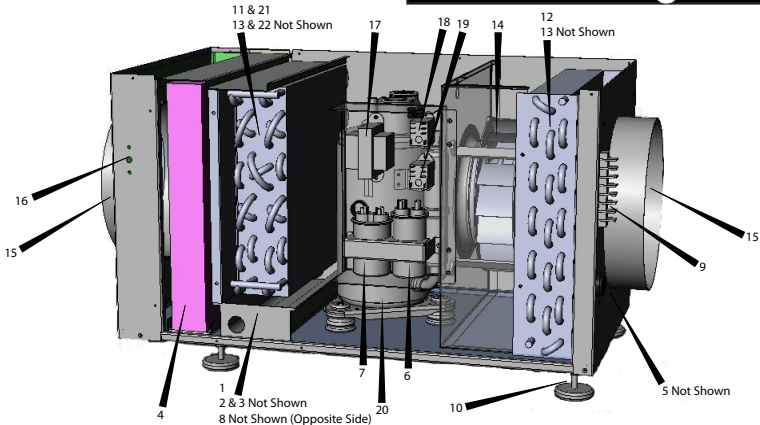

Item No.	D75 P/N	D95 P/N	Description
-	266314-001	266314-002	Complete Unit
1	266314-011	266314-012	Drain Pan
2	N/A	N/A	PVC Drain Trap
3	N/A	N/A	PVC Drain Adapter 3/4"
4	266314-021	266314-022	MERV 11 Filter
5	266314-031	266314-032	8' Power Cord
6	266314-041	266314-041	Compressor Run Capacitor
7	266314-042	266314-043	Fan Run Capacitor
8	N/A	N/A	Drain Plug 3/4" MNPT
9	266314-051	266314-051	Curtis Terminal Block
10	266314-061	266314-061	Leveling Mount Foot Base
11	N/A	N/A	Evaporated Coil
12	N/A	N/A	Coil, Condenser
13	N/A	N/A	R-410A Refrigerant
14	266314-071	266314-072	Blower, 115 volt, backward curve
15	N/A	N/A	8"/10" Collar
16	266314-081	266314-081	Humidistat
17	266314-091	266314-091	Transformer, 120/24v 20 VA
18	266314-101	266314-101	Relay, Blower, 24V
19	266314-101	266314-102	Relay, Compressor, 24V
20	266314-111	266314-112	Compressor
21	N/A	N/A	Accumulator, Assembly
22	266314-121	266314-121	Internal Freeze Stat

Warranty

Dehumidifier Limited Warranty

Applies in U.S.A. and Canada Only

FAILURE TO MAINTAIN YOUR EQUIPMENT WILL VOID THIS WARRANTY. COVERED EQUIPMENT

The following Trion Product equipment is covered by the Limited Warranty:
Whole House Dehumidifier Units: Comfort-D75 and Comfort-D95

ONE (1) YEAR COVERAGE—RESIDENTIAL APPLICATIONS

The covered equipment and covered component are warranted by Trion for a period of one (1) year from the date of the original installation, when installed in residential applications. If, during this period, a covered component fails because of a manufacturing defect, Trion will provide a free replacement part to the owner through a licensed service contractor. You must pay shipping charges and all other costs of warranty service, Trion will not pay labor involved in diagnostic calls or in removing, repairing, servicing or replacing parts. Such costs may be covered by a separate warranty provided by the installer.

EXTENDED COVERAGE - COMPRESSORS

Comfort-D75 and Comfort-D95 —Five (5) Years

Extended warranty coverage on compressors applies to the original equipment purchaser, subject to proof of purchase, and is not transferable. Compressor warranty is five (5) years in all residential applications.

NOTE: If the date of original installation cannot be verified, the warranty period will be deemed to begin two (2) months after the date of manufacture.

EXCLUDED COMPONENTS

The following components are not covered by this warranty: cabinets, cabinet pieces, air filters, driers, refrigerant, refrigerant line sets, belts, wiring, fuses, oil nozzles and unit accessories.

REPAIRS

All repairs of covered components must be made with authorized service parts by a licensed service dealer or contractor. Labor charges are not covered by this warranty. Such costs may be covered by a separate warranty provided by the installer.

CARE OF EQUIPMENT

Your new unit must be properly installed, operated and maintained in accordance with the unit installation, operation and maintenance instructions provided with each unit. Failure to provide maintenance according to Trion's instructions will void this warranty. You may be asked to provide written documentation of annual and other periodic preventive maintenance.

WARRANTY PROCEDURE

When warranty parts are required:

1. Be prepared to furnish the following information: a) Complete model and serial number, b) Proof of required periodic maintenance, installation date and location, c) An accurate description of the problem.
2. Call your local licensed service dealer or contractor.
3. If the installing dealer is unavailable or unable to provide warranty, consult a licensed service dealer or contractor in your area or contact:

Trion IAQ
101 McNeill Road
Sanford, NC 27330

WARRANTY LIMITATIONS

1. This warranty is void if the covered equipment is removed from the original installation site.
 2. This warranty does not cover damage or defect resulting from:
 - a) Flood, wind, fire, lightning, mold, or installation and operation in a corrosive atmosphere, or otherwise in contact with corrosive materials (chlorine, fluorine, salt, recycled waste water, urine, fertilizers, or other damaging substances or chemicals)
 - b) Accident, or neglect or unreasonable use or operation of the equipment including operation of electrical equipment at voltages other than the range specified on the unit nameplate (includes damages caused by brownouts)
 - c) Modification, change or alteration of the equipment, except as directed in writing by Manufacture
 - d) Operation with system components (indoor unit, outdoor unit and refrigerant control devices) which do not match or meet the specifications recommended by Manufacture
 - e) Use of contaminated or alternate refrigerant
- The installation of replacement parts under the terms of this warranty does not extend the original warranty period.

Trion makes no express warranties other than the warranty specified above. All implied warranties, including the implied warranties of merchantability and fitness for a particular purpose, are excluded to the extent to a period legally permissible. Should such exclusion or limitation of the warranty be unenforceable, such implied warranties are in any event limited to a period of one (1) year. Liability for incidental and consequential damages is excluded. Some states do not allow limitation of incidental damages, so the limitations or exclusions may not apply to you.

Trion will not pay electricity or fuel costs, or increases in electricity or fuel costs, for any reason whatsoever, including additional or unusual use of supplemental electric heat. This warranty does not cover lodging expenses or labor charges. Trion shall not be liable for any default or delay in performance under this warranty caused by any contingency beyond its control. This warranty gives you specific legal rights, and you may also have other rights which vary from state to state. Keep this warranty and your sales slip together for future reference. You must provide proof of purchase or installation date for in-warranty service.

Write down the following information about your Dehumidifier on the front cover to better help you obtain assistance or service if you ever need it. You will need to know the complete model and serial number. You can find this information located on the rating plate on the outside panel for all models.

Trion® | 101 McNeill Road | Sanford, NC 27330
Phone: 800-884-0002 | Fax: 800-458-2379
Web: www.trioniaq.com | Email: customerservice@trioniaq.com