

# Owner's Operation and Instruction Manual



**SAFETY TESTED TO ASTM 1509**  
**PATENT NO.: 7,686,011**

## **CAUTION!**

Read All Instructions Carefully  
Before Starting The Installation or  
Operating This Heater.

Improper Installation Could Void  
Your Warranty!

## **SAFETY NOTICE:**

If this heater is not properly installed, a house fire may result. For your safety, follow the installation instructions. Contact local building or fire officials about restrictions and installation requirements in your area.

## **SAVE THIS MANUAL FOR FUTURE REFERENCE**

THIS MANUAL WILL HELP YOU TO OBTAIN EFFICIENT, DEPENDABLE SERVICE FROM THE HEATER, AND ENABLE YOU TO ORDER REPAIR PARTS CORRECTLY. KEEP IN A SAFE PLACE FOR FUTURE REFERENCE.



## **United States Stove Company**

227 Industrial Park Road  
P.O. Box 151  
South Pittsburg, TN 37380



## Safety Precautions

- △ **IMPORTANT:** Read this entire manual before installing and operating this product. Failure to do so may result in property damage, bodily injury, or even death. Proper installation of this heater is crucial for safe and efficient operation.
- △ This heater must be installed in an exterior wall or window to the outside.
- △ Contact your local building officials to obtain a permit and information on any additional installation restrictions or inspection requirements in your area.
- △ Do not throw this manual away. This manual has important operating and maintenance instructions that you will need at a later time. Always follow the instructions in this manual.
- △ This heater is designed and approved for premium hardwood pellet fuel only. Any other type of fuel burned in this heater will void the warranty and safety listing.
- △ Never use gasoline, gasoline-type lantern fuel, kerosene, charcoal lighter fluid, or similar flammable liquids to start or “freshen up” a fire in this heater. Keep all such liquids well away from the heater while it is in use.
- △ A working smoke detector must be installed in the same room as this product.
- △ Do not unplug the heater if you suspect a malfunction. Turn the ON/OFF SWITCH to “OFF” and contact your dealer.
- △ Do not operate your heater with the viewing or combustion door open. The auger will not feed pellets under these circumstances and a safety concern may arise from sparks or fumes entering the room.
- △ Your heater requires periodic maintenance and cleaning (see “MAINTENANCE”). Failure to maintain your heater may lead to improper and/or unsafe operation.
- △ Never try to repair or replace any part of the heater unless instructions for doing so are given in this manual. All other work should be done by a trained technician.
- △ Turn the heater OFF and allow to completely cool before performing any maintenance.
- △ Disconnect the power cord before performing any maintenance! NOTE: Turning the ON/OFF Switch to “OFF” does not disconnect all power to the electrical components of the heater.
- △ Ashes must be disposed in a metal container with a tight fitting lid. The closed container of ashes should be placed on a non-combustible surface or on the ground, well away from all combustible materials, pending final disposal.
- △ The exhaust system should be checked bi-monthly during the burning season for any build-up of flyash, soot or creosote.
- △ Do not touch the hot surfaces of the heater. Educate all children on the dangers of a high-temperature heater. Young children should be supervised when they are in the same room as the heater.
- △ A power surge protector is required. This unit must be plugged into a 110 - 120V, 60 Hz grounded electrical outlet. Do not use an adapter plug or sever the grounding plug. Do not route the electrical cord over the heater. Do not route the cord in foot traffic areas or pinch the cord under furniture.
- △ The heater will not operate during a power outage. If a power outage does occur, check the heater for smoke spillage and open a window if any smoke spills into the room.
- △ The viewing and combustion door must be closed and sealed during operation.
- △ Never block free airflow through the open vents of the unit.
- △ Keep foreign objects out of the hopper.
- △ The moving parts of this heater are propelled by high torque electric motors. Keep all body parts away from the auger while the heater is plugged into an electrical outlet. These moving parts may begin to move at any time while the heater is plugged in.
- △ Do not place clothing or other flammable items on or near this heater.
- △ **WARNING—DO NOT INSTALL THIS UNIT IN A SLEEPING ROOM. CAUTION—THE STRUCTURAL INTEGRITY OF THE MOBILE HOME FLOOR, WALL, AND CEILING/ROOF MUST BE MAINTAINED.**
- △ This appliance is not intended for commercial use.
- △ DO NOT INSTALL A FLUE DAMPER IN THE EXHAUST VENTING SYSTEM OF THIS UNIT.
- △ DO NOT CONNECT THIS UNIT TO A CHIMNEY FLUE SERVING ANOTHER APPLIANCE.

CUT HERE



# WARRANTY INFORMATION CARD

Name \_\_\_\_\_ Telephone #: (\_\_\_\_) \_\_\_\_\_

City \_\_\_\_\_ State \_\_\_\_\_ Zip \_\_\_\_\_

Email Address \_\_\_\_\_

Model # of Unit \_\_\_\_\_ Serial # \_\_\_\_\_

Fuel Type:  Wood  Coal  Pellet  Gas  Other \_\_\_\_\_

Place of Purchase (Retailer) \_\_\_\_\_

City \_\_\_\_\_ State \_\_\_\_\_ Zip \_\_\_\_\_

If internet purchase, please list website address \_\_\_\_\_

Date of Purchase \_\_\_\_\_

Reason for Purchase:  Alternative Heat  Main Heat Source

Decoration  Cost  Other \_\_\_\_\_

What was the determining factor for purchasing your new USSC appliance? \_\_\_\_\_

I have read the owner's manual that accompanies this unit and fully understand the:  
Installation  Operation  and Maintenance  of my new USSC appliance.

\_\_\_\_\_  
Print Name

\_\_\_\_\_  
Signature

\_\_\_\_\_  
Date

**Please attach a copy of your purchase receipt.**

**Warranty not valid without a Proof of Purchase.**

**Warranty information must be received within 30 days of original purchase.**

**Detach this page from this manual, fold in half with this page to the inside and tape together. Apply a stamp and mail to the address provided. You may use an envelope if you choose.**

**You may register online by going to [www.usstove.com](http://www.usstove.com)**

All information submitted will be kept strictly confidential. Information provided will not be sold for advertising purposes.  
Contact information will be used solely for the purpose of product notifications.

CUT HERE



CUT HERE



CUT HERE



Fold Here

Fold Here

Three horizontal lines for an address.

PLACE  
STAMP  
HERE

United States Stove Company  
P.O. Box 151  
South Pittsburg, TN 37380

# Specifications

## Heating Specifications

Heat Output <sup>1</sup>	16,400 BTU/hr.
Heating Capacity <sup>2</sup>	500 - 1,000 sq. ft.
Fuel Burn Rate <sup>3</sup>	¾ - 2½ lbs./hr.
Burn Time (lowest setting)	approx. 35-40 hrs.
Hopper Capacity	approx. 30 lbs.

<sup>1</sup> BTU output will vary depending on the quality of fuel. Use PFI listed fuels for the best results.

<sup>2</sup> Heating capacity will vary depending on floor plan layout of your home, degree of insulation, and the outside temperature.

<sup>3</sup> Pellet size may effect the actual rate of fuel feed and burn times. Fuel feed rates may vary by as much as 20%. Use PFI listed fuel for best results.

## Dimensions

Height	21 <sup>3</sup> / <sub>8</sub> in.
Width	22 <sup>1</sup> / <sub>2</sub> in.
Depth	27 <sup>1</sup> / <sub>8</sub> in.
Weight	126 <sup>1</sup> / <sub>2</sub> lbs.

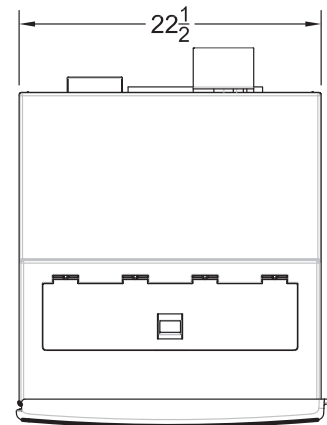

## Window / Cut-Out Dimensions

Minimum Cut-out / Window Opening	14" x 22 <sup>3</sup> / <sub>4</sub> "
----------------------------------	--

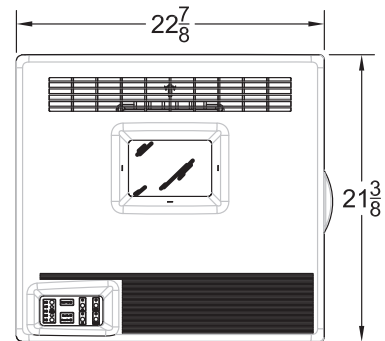
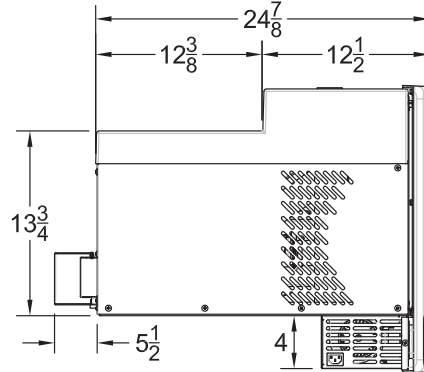

## Electrical Specifications

Electrical Rating	110-120 volts, 60 HZ, 3.0 Amps
Watts (operational)	175 (approx.)
Watts (igniter running)	425 (approx.)

## FUEL CONSIDERATIONS

Your Pellet heater is designed to burn premium hardwood pellets that comply with Association of Pellet Fuel Industries standards. (Minimum of 40 lbs per cubic ft, ¼" to 5/16" diameter, length no greater than 1½", not less than 8,200 BTU/lb, moisture under 8% by weight, ash under 1% by weight, and salt under 300 parts per million). Pellets that are soft, contain excessive amounts of loose sawdust, have been, or are wet, will result in reduced performance.

## SAFETY AND COMPLIANCE

Your Pellet heater has been safety tested and listed to ASTM E 1509, by OMNI-Test Laboratories, Inc. Portland, Oregon, USA.

## Assembly

Your HomComfort heater comes pre-assembled with the exception of the Spark Suppressor that needs to be attached to the rear of the unit on the exhaust outlet.

**DO NOT OPERATE THIS HEATER WITH THE SPARK SUPPRESSOR REMOVED!**

Using the hardware and gasket supplied, attach the suppressor to the rear of the unit as shown in the illustration.

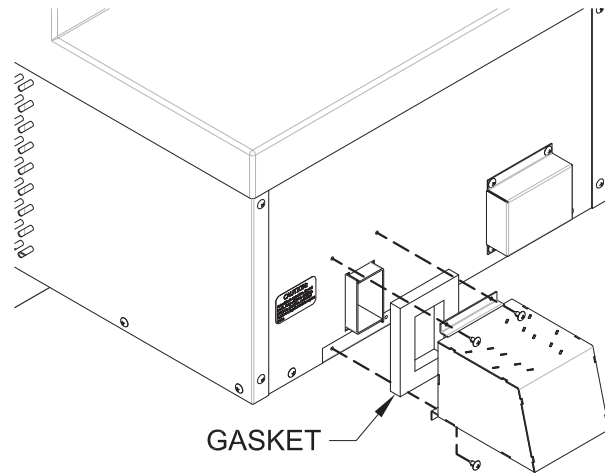

## Installation

△ **Read this entire manual before you install and use your Pellet heater. Failure to follow instructions may result in property damage, bodily injury, or even death!**

Your **Homcomfort** heater may be installed to code in either a **conventional** or **mobile home** (see SPECIAL MOBILE HOME REQUIREMENTS).

It is recommended that only a authorized technician install your heater, preferably a National Fireplace Institute (NFI) certified specialist.

This heater must be installed through an opening on an exterior wall. The heater may be installed in an existing window or opening cut through a wooden, brick, or masonry wall.

Once the desired location is selected, and before cutting a hole, check the outside of the structure for anything obstructing clearances to the exhaust vent. Also clear away leaves, shrubs/bushes, or trees that may be around the exhaust outlet.

### **VENT TERMINATION CLEARANCES:**

- A) Minimum 4-foot clearance below or beside any door or window that opens.
- B) Minimum 1-foot clearance above any door or window that opens.
- C) Minimum 2-foot clearance from any adjacent building.
- D) Minimum 7-foot clearance from any grade when adjacent to public walkways.
- E) Minimum 2-foot clearance above any grass, plants, or other combustible materials.
- F) Minimum 4-foot clearance from an forced air intake of any appliance.
- G) Minimum 2-foot clearance below eaves or overhang.
- H) Minimum 1-foot clearance horizontally from combustible wall.

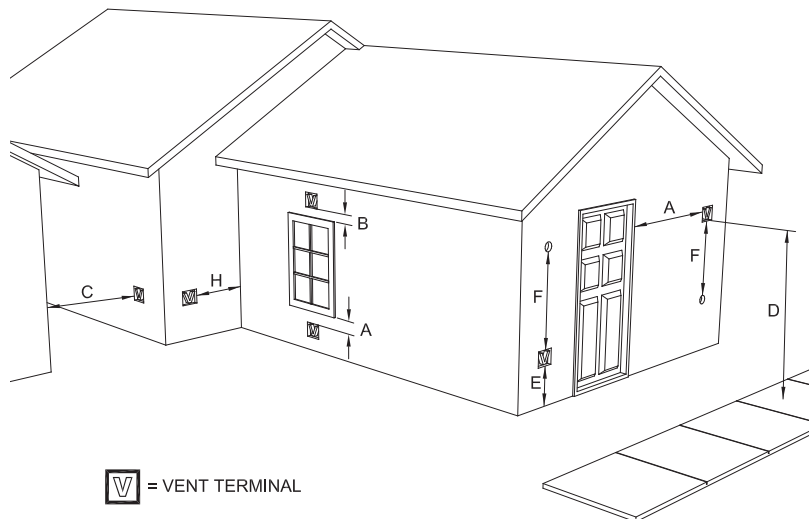

**NOTICE:** This unit shall be installed in such a way that the exhaust gases are directed so they do not jeopardize people, overheat combustible structures, or enter buildings.

INSTALL VENT AT CLEARANCES SPECIFIED ABOVE.

**IMPROPER INSTALLATION:** The manufacturer will not be held responsible for damage caused by the malfunction of a heater due to improper venting or installation. Call (800) 750-2723 and/or consult a professional installer if you have any questions.

# Installation

## FLOOR PROTECTION

This heater should have a non-combustible floor protector installed beneath it. If a floor pad is used, it should be UL listed or equal. The floor pad or non-combustible surface should be large enough to extend a minimum of 6-inches in front and 6-inches on each side of the heater.

Your heater will need a minimum 18½" x 34½" floor protector.

A Floor Protector of ¼ inch thick is recommended for this installation.

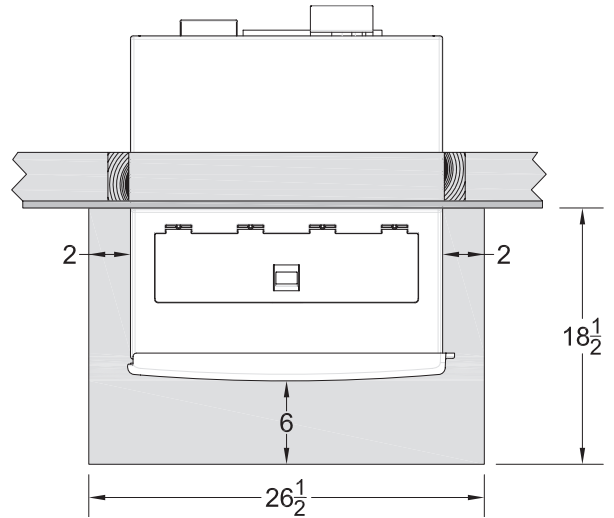

## Clearances to Combustibles

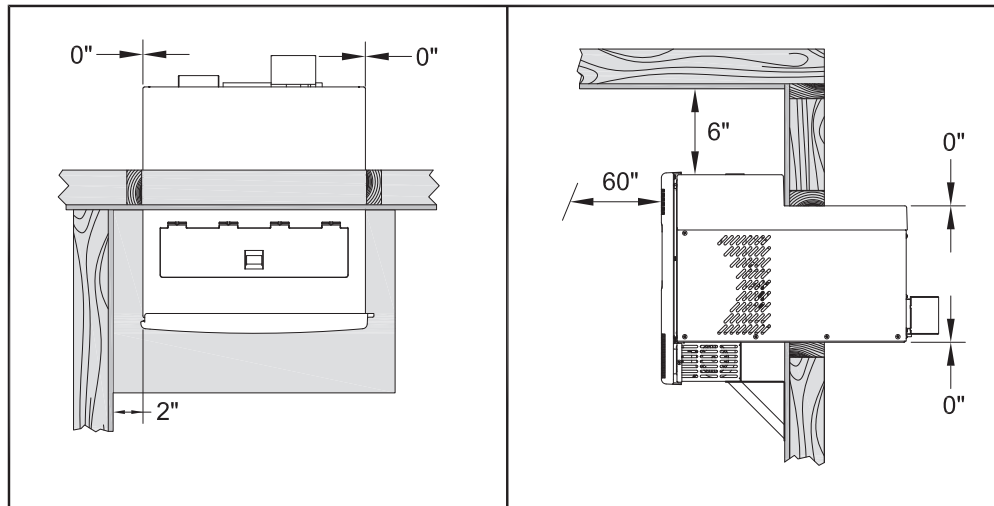

### General Installation Clearance:

This unit is approved for Zero Clearance to any installed combustible surface such as the window sash, sill, or wooden structure in a wall installation. However, clearance should be considered for ease of installation and removal for maintenance and repair.

Combustible	Clearance
Floor (Allow for brace)	6 inches
Left / Right	2 inches
Ceiling (Allow for fuel loading)	6 inches
Front	60 inches

### General Installation Notes

- ◆ Do not install heater where the exhaust will terminate in a window well or any opening below ground level.
- ◆ Special precautions may be required to prevent snow build-up within 12 inches of the air intake.
- ◆ Clearances around heater must provide adequate room for service, cleaning, and air circulation.
- ◆ **Residential Garage Installation:** The heater shall be located or protected so it is not subject to damage by a moving vehicle. Use care when selecting a good location within the garage. DO NOT locate the heater where the discharge air will be directed onto a nearby parked vehicle, as vehicle paint may discolor or rubber may harden and crack. DO NOT allow open or closed containers of paint, gasoline, or other flammable liquids to be stored in the same area as the heater.



# Window Installation

## When Installing your heater in a window

- Select a window of adequate size and with the appropriate clearances needed for a safe install. The heater will need a level resting surface, so framing may be necessary in window sill.
- First, you will install the knee/support braces and pressure plate supplied. The support braces and plate will be installed on the inside of the home, below the window, so that the bottom of the blower housing will rest on it. **Trying to align the brace with a wall stud is best for this application.** You may use the hardware supplied or purchase the appropriate fasteners from your local hardware store for the type of material you are securing into.
- Depending on your application, a solid resting surface needs to be established on the window sill. If your selected window's bottom flange rises above the seal, a board will need to be placed and should be level with or just rise above that flange. Use the illustration to the right for reference.
- The top of the support shall be approximately four(4) inches below the resting surface of the heater. Some modifications may need to be made to the surrounding trim if applicable.
- On the bottom of the blower housing, you'll find a series of holes for attaching the supports to the heater. Use the measurements in the illustration to the right to get the approximate distance between the supports. Attach the pressure plate and supports to the wall.
- After attaching the supports to the wall, install the heater into the window. Align the holes in the supports with the holes in the blower housing and attach with the supplied hardware.
- Using the window seal brackets, mount them to the side of the heater, using the existing cabinet screws, then to the top of the window seal with the screws provided. See illustration.
- Lower the sash onto the top of the heater and proceed to install the window insulation/filler panels.
- Install the window filler panels. You may choose between two options depending on your application or you may purchase a suitable alternative at your local hardware store or HVAC supply. One set of the panels are fabricated to fit a standard 32 inch window. The other is cut to fit.
- If using the panels for a 32 inch window, first cut the foam for a tight fit inside each of the metal housings. Remove the protective strips covering the 2-sided tape and install the foam in the housing, rubbing the area where the tape is to ensure the tape adheres to the foam. Install the panels on each side of the heater using the supplied 2-sided tape for attachment to the unit and window frame.
- If the window used for installation is not a standard 32 inch window, use the molded channels. Cut to fit each channel and the foam for your application. Install the panels on each side of the heater using the supplied 2-sided tape to attach to the unit and window frame.
- Seal around the outside of the heater with silicone or caulking to protect against the weather.

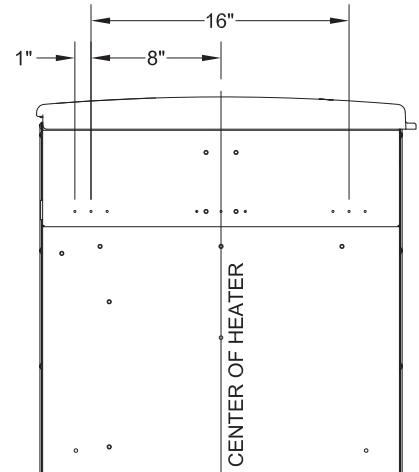
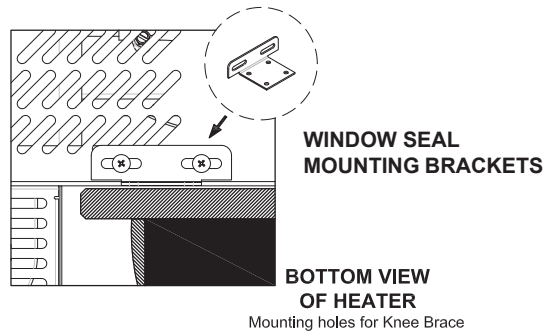
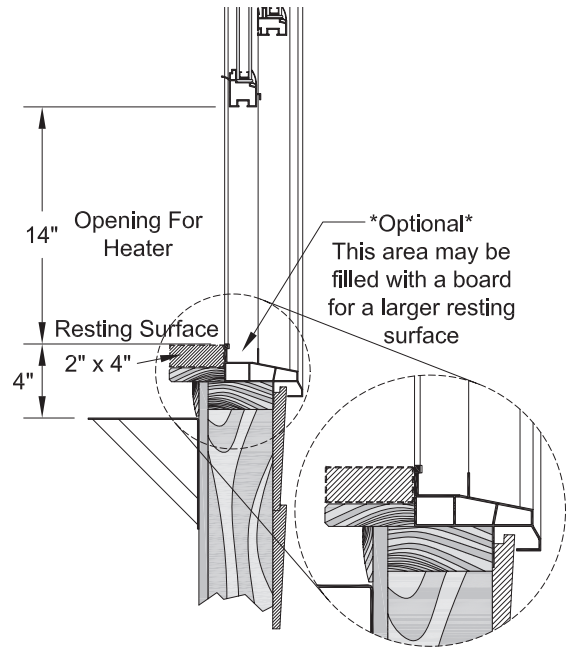

PANELS FOR 32" WINDOW

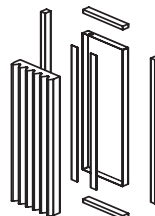

PANELS FOR CUT-TO-SIZE

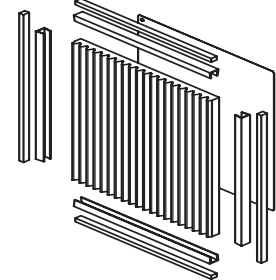



## Wall Installation

### When Installing your heater in an exterior wall

- Select a wall to the exterior of the building. This wall should have the required clearance to combustibles inside and out mentioned earlier in this manual. Make certain that electrical wires, conduit, water or gas pipes do not pass through the area you have selected
- USSC suggest the following installation illustrated to the right, however, you may frame the hole cut out to your discretion. **A sturdy base for the heater to rest should be established.**

- At the desired height, mark the hole location for your heater. Measure and cut the appropriate size hole for your installation. The cut out should border a wall stud. The next wall stud will need to be cut.

Build a frame of 2 x 4's at the dimensions suggested and secure it in place by attaching it to the available studs.

- Before installing the heater, install the Knee/Support Braces.
- Install the knee/support braces and pressure plate supplied. The support brace will be installed on the inside of the home, below the cut-out, so that the bottom of the blower housing will rest on it. **Trying to align the brace with a wall stud is best for this application.** You may use the hardware supplied or purchase the appropriate fasteners from your local hardware store for the type of material you are securing into.
- The top of the support shall be approximately four(4) inches below the resting surface of the heater. Some modifications may need to be made to the surrounding trim if applicable.
- On the bottom of the blower housing, you'll find a series of holes for attaching the supports to the heater. Use the measurements in the illustration to the right to get the approximate distance between the supports if two brackets are used. If only one is selected, position it in the center of the window. Attach the support(s) to the wall.
- After attaching the supports to the wall, install the heater into the opening. Align the holes in the supports with the holes in the blower housing and attach with the supplied hardware.
- Seal around the heater with silicone or caulking to protect against the weather.

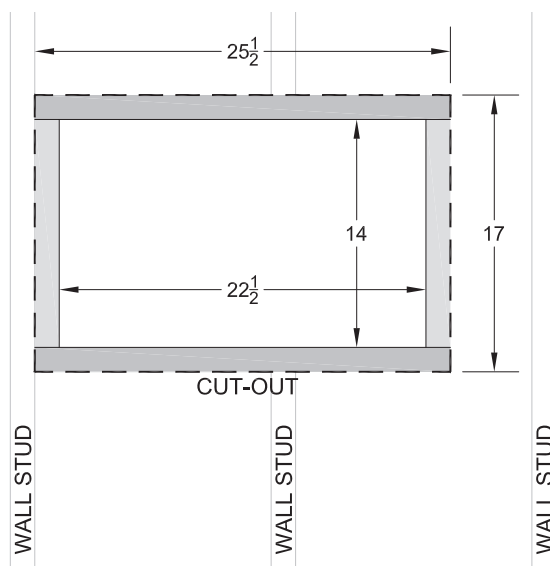

## Mobile Home Installation Requirements

△ **WARNING! - DO NOT INSTALL IN A SLEEPING ROOM**

△ **CAUTION! - THE STRUCTURAL INTEGRITY OF THE MOBILE HOME FLOOR, WALL, AND CEILING/ROOF MUST BE MAINTAINED.**

- The heater must be permanently attached to the wall.
- The heater must be electrically grounded to the steel chassis of the mobile home with 8 GA copper wire using a serrated or star washer to penetrate paint or protective coating to ensure grounding.
- When moving your mobile home, the heater must be removed while the mobile home is being relocated. After relocation, heater may be reinstalled and securely fastened.
- Check with your local building officials as other codes may apply.

## Understanding your heater

### How your heater works

Your **HomComfort** heater utilizes a inclined auger fuel feed system that is operated by a microprocessor controlled digital circuit board. The digital circuit board allows the inclined auger fuel feed system to run in a timer-based, non-continuous cycle; this cycling allows the auger to run for a predetermined period of seconds. The auger pushes pellets up a chute located at the front/bottom of the hopper which in turn falls through another chute into the burnpot. Your heater is equipped with an automatic ignition system that should ignite the fuel within 5-10 minutes from pressing the ON button. As pellets enter the burn pot and ignite, outside air is drawn across the fuel and heated during the combustion process; The post combustion gases are then pulled through the heat exchanger by the exhaust motor or draft fan. As the heater warms up, room air is circulated around the heat exchanger by means of a room air blower, distributing warm air into the room.

The amount of heat produced by the heater is proportional to the rate of the fuel that is burned, and this rate is controlled by the "HEAT RANGE" setting.

Because a forced draft pressure is required for the combustion process inside your heater, it is extremely important that the exhaust system be properly maintained. And, that when operating your heater, you make sure that the viewing and combustion doors are properly closed and/or sealed.

## Control Panel Overview

Turning the heater ON/OFF, as well as adjustments for the fuel feed rate is performed by pressing the appropriate button(s) on the control panel which is located on the front, lower left-hand corner of your heater.

### ON/OFF

- Pressing the "ON" button on the control panel will begin the start-up sequence for the heater. Fuel will begin to feed through the auger feed system then ignite after approx. 5 minutes.
- Pressing the "OFF" button on the control panel will cause the heater to enter its shut-down sequence. The fuel feed system will stop pulling fuel from the hopper and, once the fire goes out and the heater cools down, the fans will stop running.

### HEAT RANGE

- Pressing the "Heat Range" arrows, up or down, will adjust the amount of fuel being delivered to the burnpot.
- The exhaust fan will begin to run at 100%
- Once the heater reached 150°F, the room fan will come on.

### LIGHT (LED) INDICATORS

- Heat Range LED - displays the selected heat setting. Number "1" LED lights to display that there is power to unit even if the heater is off.
- Room Fan LED - lights when room fan is running
- Door Sw LED - lights when front viewing door is opened or if the hopper lid is raised.
- Press Sw LED - lights if pressure is lost inside the combustion chamber. (See "Errors")
- A & B LED's - Factory Diagnostics
- ON LED - Flashes in start-up mode. On solid during Run mode
- OFF LED - Flashes during shut down mode

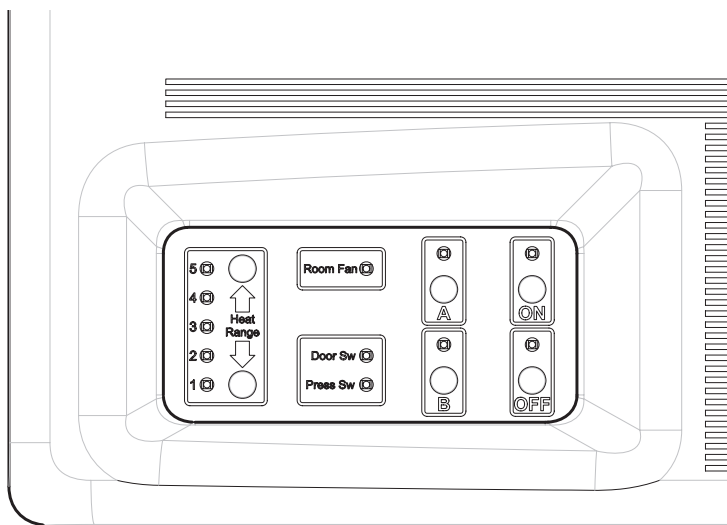

# Operation

## **UNIT PREPARATION**

After properly installing your heater, you will need to perform the following steps before operation:

- Attach the electrical cord to the left side blower housing first; then plug it into a 110-volt outlet (**an outlet surge protector is highly recommended**).

## **PERFORMING A “DRY RUN”**

Perform a “dry run” on your heater prior to making the exhaust/inlet connections and starting your heater for the first time.

1. Check that there is NO fuel or ANY foreign material in the hopper or burn-pot.
2. Check that the combustion door, viewing door and hopper lid is securely closed.
3. Press the “ON” button on the control panel. Verify that the ON LED is lit (blinking) and the “1” LED is lit.
4. You should hear the exhaust (draft) fan running immediately and the auger should begin turning continuously.
5. The auto fuel ignitor (located inside the backwall of the burnpot) should begin to glow red/orange after 3 minutes.
6. The Room Fan will not operate at this time since the unit must reach a factory preset temperature.

*DO NOT open the viewing door, the **auto-start igniter** will get very hot during this test. The heater will automatically shut down after approximately 14 minutes.*

## **START-UP PROCEDURE**

△ **Never use gasoline, gasoline-type lantern fuel, kerosene, charcoal lighter fluid, or similar liquids to start or “freshen up” a fire in this heater. Keep all such liquids well away from the heater while it is in use.**

1. Verify that the hopper is clean and free of foreign matter.
2. Fill the hopper with wood pellets; do not allow any part of the bag or any other foreign material into the hopper, as this may jam the auger.
3. Ensure that all pellet matter is cleared from the hopper seating surface.
4. Close the hopper lid. **The unit WILL NOT feed fuel with the hopper lid open.**
6. Make sure that the viewing door and combustion door is securely closed (the safety switch will not allow the heater to feed fuel if they are left open).
7. Press the “ON” button on the control pad and set the “HEAT RANGE” to your desired setting.

### **What will happen next....**

The heater will begin to feed fuel and the **auto-start ignitor** will ignite the fuel in approximately 5-10 minutes. In the start-up mode, the “ON” LED will flash until it reaches a factory preset temperature. At that point, the “ON” LED will come on solid and the heater will begin to ramp up to your selected heat range.

The Room Air Blower will not function until the heater reaches a factory preset temperature of 150°F.

## **SHUT DOWN PROCEDURE**

Press the “OFF” button on the control pad to put the stove in shut down mode. At this time, the red light above the pad will illuminate. Once this is done, the auger will stop feeding pellets, but the distribution blower and exhaust blower will continue to operate. When the internal temperature of the unit drops below the factory preset temperature, the distribution blower and exhaust blower will cease to operate. The red light will then shut off and the unit will be completely shut down.

The hotter the unit is during its operation, the longer it will take for the stove to complete the shut down cycle. If the stove stays on for more than 1 hour after pressing the “OFF” button and you are sure that the fire is out, the stove can be unplugged from the outlet. After approximately 10 seconds, the unit can be re-connected to the power source and the control board will be reset.

**WARNING: Never shut down this unit by unplugging it from the power source.**

## Operation

### DAILY OPERATION continued...

**Never place your hand near the auger while the heater is in operation.**

This unit should be filled when the hopper level drops below 3-inches.

In the event of a **power outage**, the heater WILL NOT function. If the unit was “**ON**” when the power outage occurred, one of the following will take place:

- 1.) If the heater is still warm, it will resume feeding fuel and continue to operate normally. If the fire has gone out, you will have to press the “**OFF**” button and then the “**ON**” button again to begin a new start-up sequence.
- 2.) If the heater has cooled-off, it will reset to its “**OFF**” condition. At this point, you may press the “**ON**” button and the unit will begin a new start-up sequence.

NOTE: The unit will also shut down in the event of an exhaust blower failure; if this is the case, the unit will not re-start and you must contact Customer Service at (800) 750-2723.

### SAFETY AND CONVENIENCE FEATURES

Your *HomComfort* incorporates **safety switches** that helps ensure that everything is in proper working order before feeding fuel to the burn pot. The heater will not operate if the viewing or combustion door is left open; or if the exhaust blower fails or the exhaust system is blocked.

The **RTD**, Resistance Temperature Detectors, will prevent your heater from operating at abnormally high temperatures. The heater has two over temperature limits. If the unit reaches the first limit, it will reduce fuel consumption in order to reduce temperatures. If the unit reaches the second limit, it will shut down and will need to be restarted.

Your heater also includes an **auto-start igniter** as a standard feature. The use of other fire starter materials (wood chips, starter gel, etc.) is not necessary. By simply pressing the “**ON**” button on the digital control panel, your heater will begin to feed fuel and automatically start within 5 minutes.

## Maintenance

- △ **Failure to clean and maintain this unit as indicated can result in poor performance and safety hazards.**
- △ **Unplug your heater’s electrical cord prior to removing the back panel or opening the exhaust system for any inspection, cleaning, or maintenance work.**
- △ **Never perform any inspections, cleaning, or maintenance on a hot heater.**
- △ **Do not operate heater with broken glass , leakage of flue gas may result.**

### EXHAUST SYSTEM

The by products of combustion contain small particles of fly ash. Fly ash will collect in the exhaust venting system and restrict the flow of flue gases. Incomplete combustion, such as during startup, shutdown, or incorrect operation of the heater will lead to soot formation which will collect in the exhaust system. Therefore, it is important that the exhaust system be **inspected and cleaned at least bi-monthly** during the burning season. Cleaning or monitoring the areas behind the front cleanout door should be done frequently to ensure minimum fly ash build-up. Occasionally remove the spark suppressor from the rear of the heater and clean thoroughly with soapy water. Before reinstallation, ensure that the suppressor is completely dry. If moisture is present inside the suppressor, accumulation of fly ash will be greater and will require cleaning more frequently.

# Maintenance

## **INTERIOR CHAMBERS**

Periodically remove and clean the burnpot and the areas behind the cleanout door. In particular, it is advisable to clean out the holes in the burnpot to remove any build up that may prevent air from moving through the burn pot freely.

If a vacuum is used to clean your heater, we suggest using a vacuum designed for ash removal. Some regular vacuum cleaner (i.e. shop vacs) may leak ash into the room.

## **ASH DISPOSAL**

Ashes should be placed in a metal container with a tight fitting lid. The closed container of ashes should be placed on a noncombustible floor or on the ground, well away from all combustible materials, pending final disposal. If the ashes are disposed of by burial in soil or otherwise locally dispersed, they should be retained in the closed container until all cinders have been thoroughly cooled.

## **CHECK AND CLEAN THE HOPPER**

Check the hopper periodically to determine if there is any sawdust or pellets that are sticking to the hopper surface. Clean as needed.

## **DOOR AND GLASS GASKETS**

Inspect the doors and glass window gaskets periodically. The main door may need to be removed to have frayed, broken, or compacted gaskets replaced by your Authorized HomComfort Dealer.

## **BLOWER MOTORS**

Clean the air holes on the motors of both the exhaust and distribution blowers annually. Remove the exhaust blower from the exhaust duct and clean out the internal fan blades as part of your fall start-up.

## **PAINTED SURFACES**

Painted surfaces may be wiped down with a damp cloth. If scratches appear, or you wish to renew your paint, contact your Authorized HomComfort Dealer to obtain a can of suitable high-temperature paint.

## **GLASS**

We recommend using a high quality glass cleaner. Should a build up of creosote or carbon accumulate, you may wish to use 000 steel wool and water to clean the glass. In the event you need to replace the glass, only high temperature ceramic glass of the correct size and thickness may be used. Contact your Authorized HomComfort Dealer to obtain this glass.

## **FALL START UP**

Prior to starting the first fire of the heating season, check the outside area around the exhaust and air intake systems for obstructions including leaves, bushes/shrubs, and/or trees. Clean and remove any fly ash from the exhaust venting system. Clean any screens on the exhaust system and on the outside air intake pipe. Turn all of the controls on and make sure that they are working properly. This is also a good time to give the entire heater a good cleaning throughout.

## **SPRING SHUTDOWN**

After the last burn in the spring, remove any remaining pellets from the hopper and the auger feed system. Scoop out the pellets and then run the auger until the hopper is empty and pellets stop flowing. Vacuum out the hopper. Thoroughly clean the burnpot, and firebox. It may be desirable to spray the inside of the cleaned hopper with an aerosol silicone spray if your heater is in a high humidity area. The exhaust system should be thoroughly cleaned.

## **YEARLY SERVICING**

A yearly servicing and cleaning by your Authorized Homcomfort Dealer is recommended. A fee may be charged for this service.

## Trouble Shooting Errors

- △ **Disconnect the power cord before performing any maintenance! NOTE: Turning the ON/OFF Switch to "OFF" does not disconnect all power to the electrical components of the heater.**
- △ **Never try to repair or replace any part of the heater unless instructions for doing so are given in this manual. All other work should be done by a trained technician.**

<b>PROBLEM</b>	<b>CAUSE:</b> To rich air/fuel mixture
Orange, lazy flame, excessive fuel build-up in the burnpot	<ul style="list-style-type: none"> <li>• Clean out the burnpot and behind the cleanout door.</li> <li>• Make sure that the combustion door is closed and sealed properly. If not, adjust door catch and/or replace door gaskets.</li> <li>• Check that the exhaust is clear of any obstructions. Clean as needed</li> </ul>

<b>PROBLEM</b>	<b>CAUSE:</b> Burnpot burns out of fuel
Fire goes out or heater shuts down.	<ul style="list-style-type: none"> <li>• Hopper is empty, refill the hopper.</li> <li>• Loss of draft pressure. Make sure that the combustion door is closed and sealed properly. If not, adjust door catch and/or replace door gaskets. Check that the exhaust is clear of any obstructions. Clean as needed.</li> <li>• Make sure the viewing door and hopper lid is closed completely.</li> <li>• Auger system is jammed or there is a "bridging" of the fuel in the hopper, preventing fuel from flowing into the auger feed system.</li> </ul>

<b>PROBLEM</b>	<b>CAUSE:</b> Auto-Start Igniter fails to ignite the fuel in the burn pot.
Heater does not start a fire when the "ON" button is pushed	<ul style="list-style-type: none"> <li>• Turn the heater "OFF". Clear the un-burnt fuel from the burnpot and try again.</li> <li>• Check the pellet quality. Replace if moist, wet, or dirty.</li> <li>• Loss of draft pressure. Make sure that the combustion door is closed and sealed properly. If not, adjust door catch and/or replace door gaskets. Check that the exhaust is clear of any obstructions. Clean as needed.</li> <li>• Check that the auto-start igniter is not blocked with ash or soot. (The igniter is located behind the burnpot on the back wall of the combustion chamber.)</li> <li>• The auto-start igniter gets "red hot" during start-up. If you can not visibly see the igniter glowing during start-up, then the igniter may need to be replaced or there is a problem with the electrical control system.</li> </ul>

<b>PROBLEM</b>	<b>CAUSE:</b> Heater has reached the 2nd over temperature limit.
Heater enters shut-down mode	<ul style="list-style-type: none"> <li>• To much fuel in the burnpot. Restart heater.</li> <li>• RTD sensor in the room discharge air may be faulty causing the room fan not to come on. Contact your dealer.</li> </ul>

# Wiring Diagram

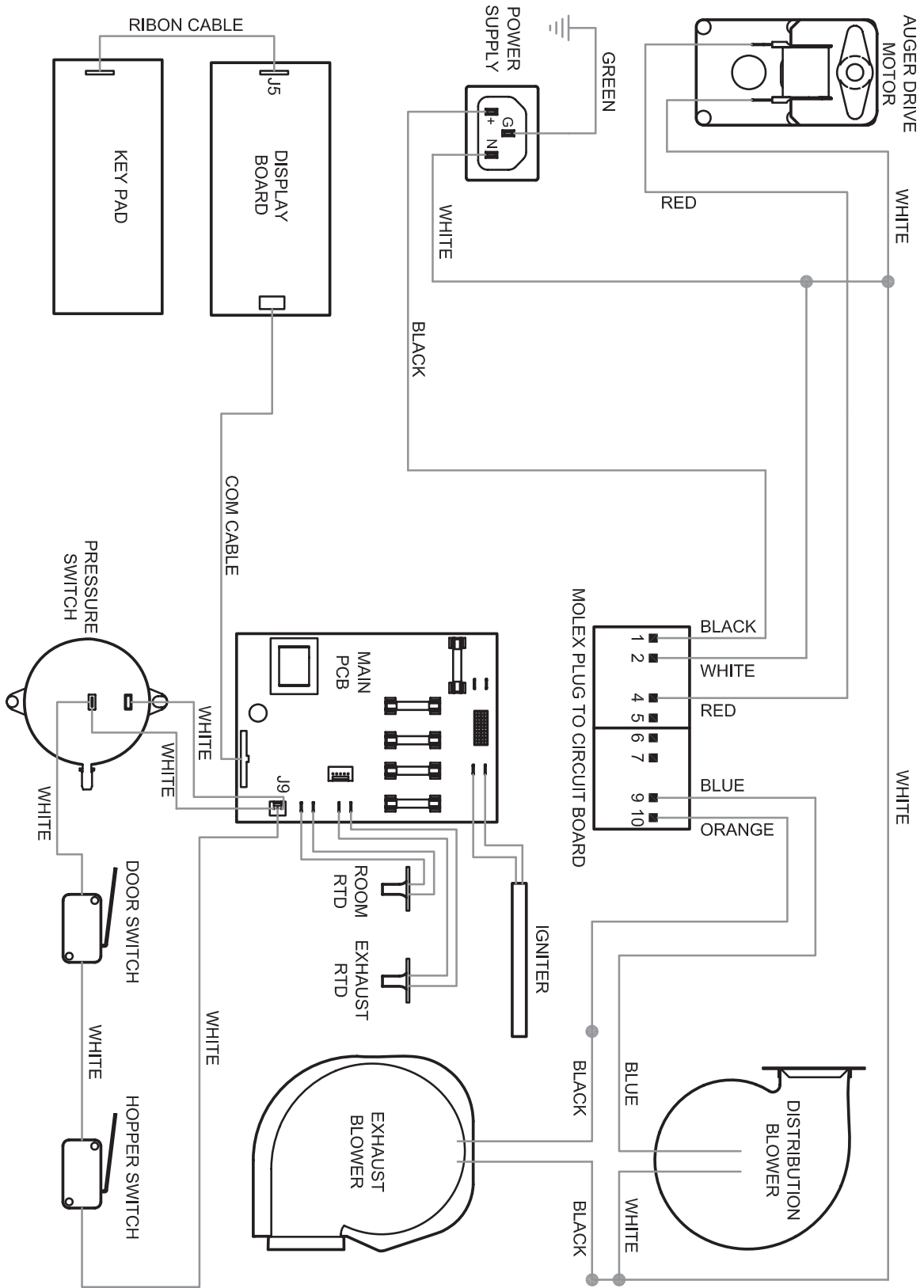



# Parts Diagram

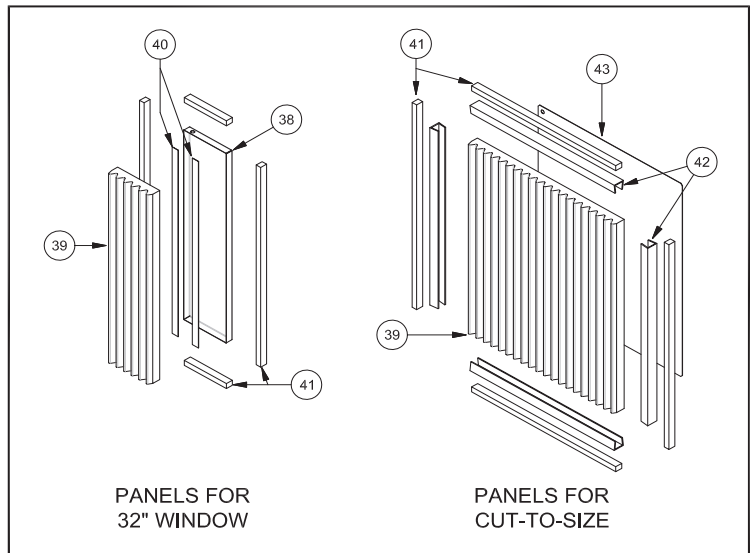
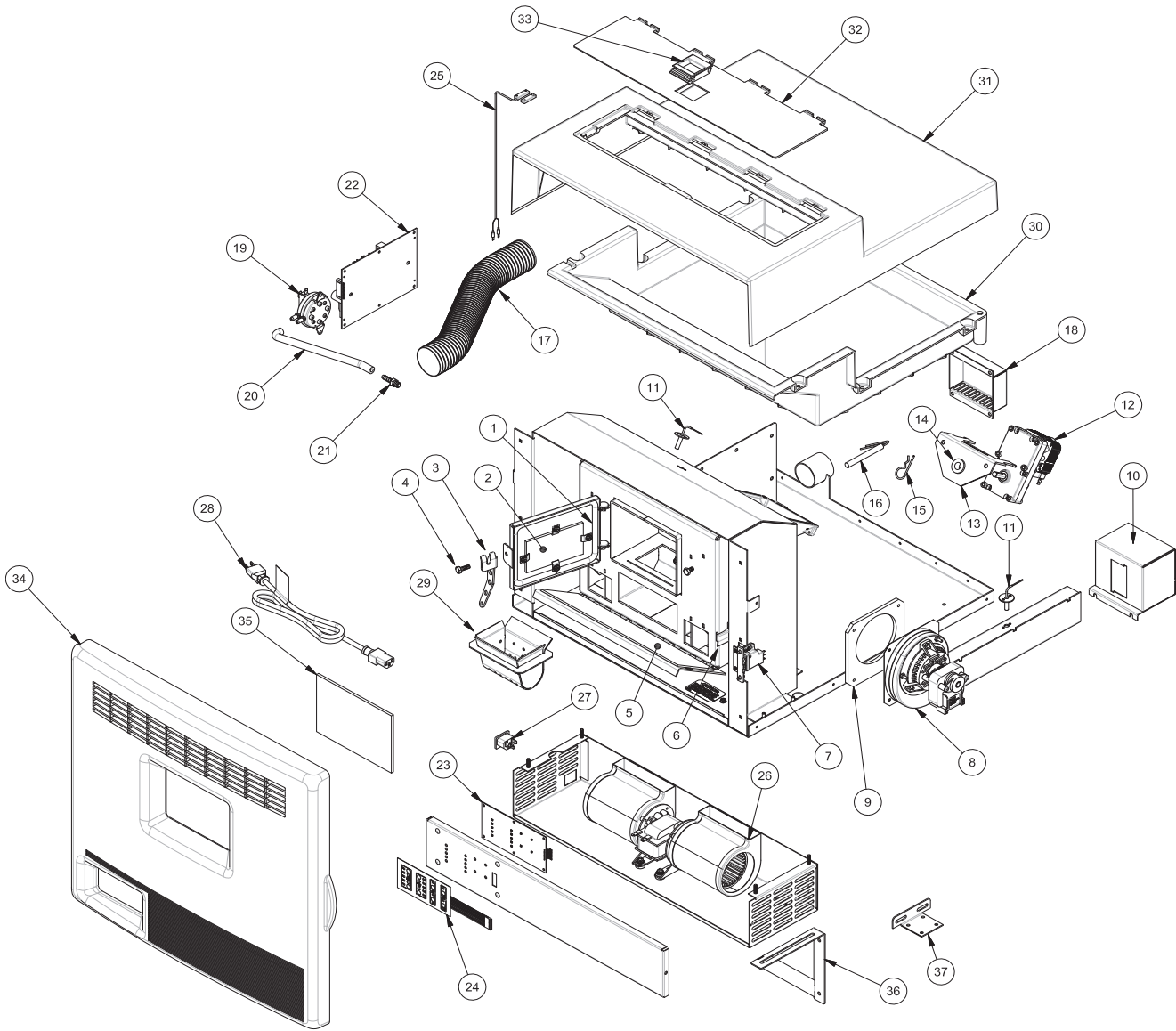

## Parts List

<b>2400</b>			
<b>Item</b>	<b>Part No.</b>	<b>Title</b>	<b>Qty.</b>
1	88033	3/8" Rope Gasket	3 FT
2	891544	Glass, Combustion Chamber	1
3	891746	Latch, Door	1
4	83339	1/4-20 Bolt	1
N/S	83261	1/4-20 Lock Nut	1
5	88144	Gasket, Cleanout	1
6	891540	Draw Latch	2
7	891542	Latch, Push-to-Close/Microswitch	1
8	80573	Blower, Exhaust - 70CFM	1
9	88129	Gasket, Exhaust Blower	1
10	891702	Suppressor, Spark	1
11	80531	Resistance Temp. Detector (RTD)	2
12	80529	Motor, Auger	1
13	891747	Assy., Auger Bushing (Includes item 14)	1
14	891132	Agitator Bushing	1
N/S	83534	Bushing Retainer Ring	1
15	83529	Hairpin	1
16	80543	Ignitor Cartridge	1
17	86615	2" ID x 18" Flex MTL Hose	1
18	891589	Cover, Intake	1
19	80549	Switch, Pressure	1
20	891121	Hose, Silicone	1 FT
21	89586	Nipple, Auger	1
22	80545	Controller Board Assy.	1
23	80555	PWA, Display Board	1
24	80550	Keypad, Assembly	1
N/S	80544	Wiring Harness, Main	1
N/S	80559	Wiring Harness, Switches	1
N/S	80551	Wiring Harness, Display Interface	1
25	80546	Proximity Switch	1
26	80542	Room Blower 125CFM	1
27	80462	Receptacle, 3 Prong	1
28	80557	Power Supply Cord	1
29	891588	Burn Pot	1
30	891534	Hopper	1
31	891532	Top, Cabinet	1
32	891533	Lid, Fuel	1
33	891541	Slide Latch	1
34	891535	Front	1
35	891545	Glass, Front Viewing	1
36	891590	Weldment, Knee/Support Brace	2
37	891742	Support Bracket (Window Seal)	2
38	891703	Housing, Filler Panel	2
39	891587	Insulation Filler Panels (12" x 14-1/2")	2
40	88137	Tape, DBL-Sided (14 inches)	4
41	88109	3/8 x 1/2 Sponge Strip	9 FT
42	891600	Channel Molding	8
43	891704	Backing Plate, Filler Panel	2

# Notes

# Notes

## HOW TO ORDER REPAIR PARTS

THIS MANUAL WILL HELP YOU OBTAIN EFFICIENT, DEPENDABLE SERVICE FROM YOUR HOMCOMFORT, AND ENABLE YOU TO ORDER REPAIR PARTS CORRECTLY.

KEEP THIS MANUAL IN A SAFE PLACE FOR FUTURE REFERENCE.

WHEN WRITING, ALWAYS GIVE THE FULL MODEL NUMBER WHICH IS ON THE NAMEPLATE ATTACHED TO THE HEATER.

WHEN ORDERING REPAIR PARTS, ALWAYS GIVE THE FOLLOWING INFORMATION AS SHOWN IN THIS LIST:

1. THE PART NUMBER
2. THE PART DESCRIPTION
3. THE MODEL NUMBER: 2400
4. THE SERIAL NUMBER: \_\_\_\_\_



United States Stove Company  
227 Industrial Park Road  
P.O. Box 151  
South Pittsburg, TN 37380  
(800) 750-2723  
[WWW.USSTOVE.COM](http://WWW.USSTOVE.COM)