

User's Manual

LINER SERIES

WS-69TB30 (22")

WS-69TB36 (22")

WS-69TS30 (18")

WS-69TS36 (18")

NOTE: This unit was designed for indoor residential use and DUCTED operation only.

DO NOT USE OVER A WOOD GRILL OR MOUNT OUTDOOR



Please read this operation manual thoroughly before using your range hood. Store it in a safe location for when you need to reference it in the future.

Table of Contents

<i>Safety Information</i>	2 – 3
<i>Content Checklist</i>	4
<i>Measurements</i>	5
<i>Preparation</i>	6
<i>Installation</i>	7
<i>Installation Diagram</i>	8
<i>Operation & Features</i>	9 – 11
<i>Cleaning & Maintenance</i>	12
<i>Troubleshooting</i>	13
<i>Parts List / Replacement</i>	14
<i>Warranty / Contact Us</i>	15 – 16

SAFETY INFORMATION**TO REDUCE THE RISK OF A FIRE, ELECTRICAL SHOCK, AND/OR INJURY OBSERVE THE FOLLOWING:**

- Unit is intended for indoor residential use only. If you should have questions, contact the manufacturer at the address or telephone number listed in the warranty.
- In case the unit should need to be cleaned or repaired, switch power off at either breaker or by disconnecting the power cord from the outlet.
- Installation work and electrical wiring must be done by a qualified technician in accordance with all applicable codes and standards, including fire-rated construction.
- Sufficient air is needed for proper combustion and exhausting of gases through the flue (chimney) of fuel burning equipment to prevent back drafting. Follow the heating equipment manufacturer's guideline and safety standards such as those published by the National Fire Protection Association (NFPA), and the American Society of Heating, Refrigeration and Air Conditioning Engineers (ASHRAE), and the local code authorities.
- Because the unit is made of stainless steel, it may contain sharp edges. Be careful to avoid cuts and abrasions by wearing protective gloves during installation and cleaning.
- Before you begin to cut or drill into the wall, verify that there is no electrical wiring or any other hidden electrical components.
- Ducted fans must always be vented to the outdoors.
- Use metal ductwork when possible.
- Do not use this fan with any solid-state speed control device and/or in-line motor.
- The unit must be properly grounded before beginning operation.



TO REDUCE THE RISK OF A RANGE TOP GREASE FIRE:

- Regardless of heat level, never leave any surface materials unattended while operating an open flame.
- Always turn hood ON when cooking at high heat or when flambéing food (i.e. Crepes Suzette, Cherries Jubilee, Peppercorn Beef Flambé).
- Depending on amount of usage, clean ventilating fans and filters frequently. Grease should not be allowed to accumulate on fan or filter. For instructions on the how to clean, see maintenance page.



TO REDUCE THE RISK OF INJURY TO PERSONS IN THE EVENT OF A RANGE TOP GREASE FIRE, OBSERVE THE FOLLOWING:

- SMOTHER FLAMES with a close-fitting lid, cookie sheet, or metal tray, then turn off the burner. BE CAREFUL TO PREVENT BURNS. If the flames do not go out immediately, EVACUATE AND CALL 911.
 - NEVER PICK UP A FLAMING PAN — Doing so may result in serious burns and possibly spread the fire.
 - DO NOT USE WATER – Grease fire must be extinguished before further action may be taken. Using water will agitate the grease and may cause a violent steam explosion.
 - Use a Fire Extinguisher ONLY if:
 - ❖ You have a Class ABC extinguisher, and you already know how to operate it.
 - ❖ The fire is small and contained in the area where it started.
 - ❖ The fire department is being called.
 - ❖ You are able to safely control the fire with your back to an open exit. *
- Based on “Kitchen Fire safety Tips” published by NFPA.

CONTENT CHECKLIST**1. CONTENTS INCLUDED**

- a. (1) WS-69 series (30" or 36") hood assembly
- b. (1) User's manual
- c. (1) 6" to 7" conversion collar
- d. (2) Baffle filters w/ handles & (2) stainless steel filler (30" model only)
- e. (2) Baffle filters w/ handles & (2) stainless steel filler (36" model only)
- f. (1) Screw packet

2. CONTENTS NOT INCLUDED

- a. WS-69CFMR (CFM reducer)
- b. 6" / 7" Aluminum or metal piping

3. TOOLS REQUIRED (NOT INCLUDED)

- a. Safety gloves
- b. Safety glasses
- c. Electric drill w/ starter bit
- d. Utility knife
- e. Philips screwdriver
- f. Spirit level
- g. Measuring tape
- h. Writing instrument (pen, marker, pencil)
- i. Aluminum tape

MEASUREMENTS **5**

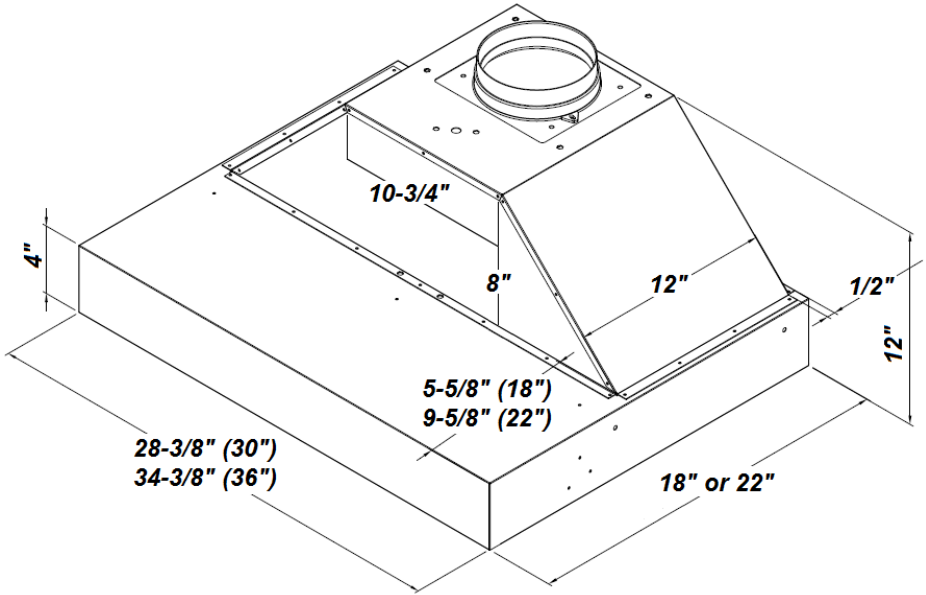

PREPARATION

1. BEFORE YOU START

- a. Be sure you have all the content of your purchase and required tools for this installation.
- b. Installation may take at least 1 to 2 hours from start to finish.
- c. Plan to use as few elbows or turns as possible for more efficient air flow.
- d. Collar size may need to be increased if utilizing a long duct run.
- e. At least 12" of vertical duct is required before any turn.
- f. Do not try to install this unit by yourself, **SERIOUS INJURY MAY OCCUR.**
- g. At least two people are needed for installation.
- h. Hiring a certified installer and electrician is recommended.
- i. Cold weather installation will require make-up air or a CFM reducer.
Check with your local building codes for more detail.

2. LOCATION

- a. Determine the exact location you want to install the range hood.
- b. Depending on the height of your ceiling, distance between cooktop and range hood should be between 27"-33".
- c. Range hood should be mounted at stated measurements to ensure performance and lifespan of electrical components.
- d. Correctly measure the dimension needed to install the unit.

3. HOOD LINER

- a. Inspect for any sign of defect or damage. (i.e. scratches, dents, loose seams, etc.)
- b. Power up the unit to make sure it is working properly.
- c. Remove the baffle filters and unscrew the fillers.
- d. Remove the protective file on the baffle filters and fillers.
- e. Install baffle handles to filters using a Philips screwdriver.

INSTALLATION

1. DUCTED INSTALLATION

- a. Make sure all preparation steps are completed.
- b. Determine where you would like to mount the hood.
- c. Lift the unit up flush against the wall.
- d. Be sure the unit is leveled and parallel.
- e. Using the screws and washers provided, tightly secure the unit against the wall and the cabinet frame.

NOTE: Install additional screws through the back of the unit if necessary.

- f. Use the conversion collar for 7" ducting. (OPTIONAL)
- g. Connect 6" or 7" ducting to the collar of the hood.
- h. Finish off by sealing the connection point with aluminum tape.

2. COLD WEATHER INSTALLATION (OPTIONAL)

NOTE: WS-69CFMR is only compatible with 6" top round outlet

- a. Check with your local building codes to see if a CFM reducer is an acceptable alternative to make-up air.
- b. Remove the WS-69CFMR (CFM Reducer) and inspect for any sign of defect or damage. (i.e. Cracks, broken/defective sections)
- c. **AFTER COMPLETING Step A – E of Section 1 DUCTED INSTALLATION (Top round outlet)**
- d. Place the CFM reducer onto the outlet of the unit and seal the connection point with aluminum tape. (Be sure it is secured with no opening or gaps)
- e. Connect a 6" ducting to the collar of the CFM reducer.
- f. Finish off by sealing other connection points with aluminum tape.

Installation diagram available on next page

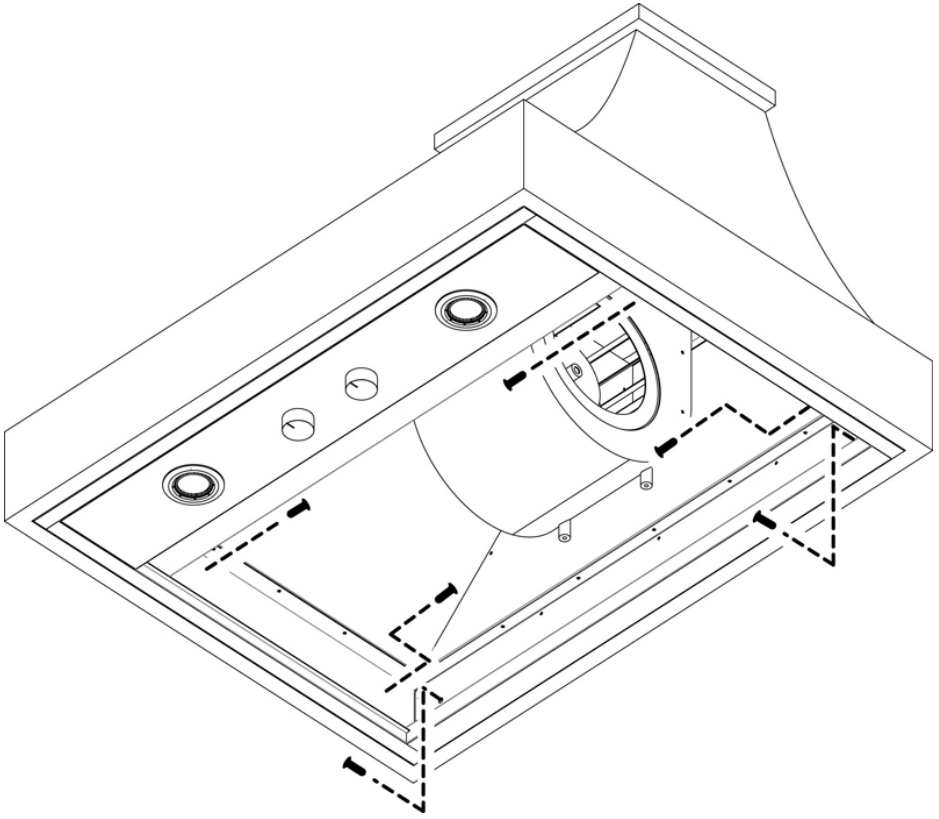
8**INSTALLATION DIAGRAM**

OPERATION & FEATURES

1. EASY ACCESS KNOB CONTROL

- a. Knob 1 – Light ON / OFF
- b. Knob 2 – Speed
 - i. 1 – Low speed
 - ii. 2 – Medium speed
 - iii. 3 – High speed

2. BAFFLE FILTERS

- a. (2) 14-3/8" x 12-3/4" baffle filters and (2) fillers (30" model only)
- b. (2) 14-3/8" x 12-3/4" baffle filters and (2) fillers (36" model only)

3. REMOVING THE BAFFLE FILTERS

- ① Slide the baffle filter into the hood.
- ② Push the baffle filter upward.
- ③ Slide the baffle filter toward you.
- ④ Pull the end of the baffle filter downward.
- ⑤ Fit into place.

4. REPLACING LIGHT SET

NOTE: BE SURE THE LIGHTS ARE NOT HOT

****Use maximum of 35W Halogen/ 8W LED GU10 Light Bulb****

- a. Unscrew outer light ring counter clock wise.
- b. Outer light ring should drop down along with the light bulb.
- c. Slightly pull the light away from the ring.
- d. Move light to left or right side of the ring.
- e. Twist light bulb counter clock wise to release from socket.
- f. Replace light bulb.

*****STEP BY STEP DIAGRAM ON NEXT PAGE*****

10 OPERATION & FEATURES

Fig. 3a

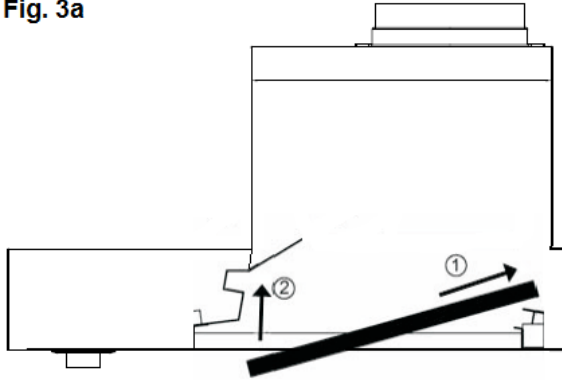

Fig. 3b

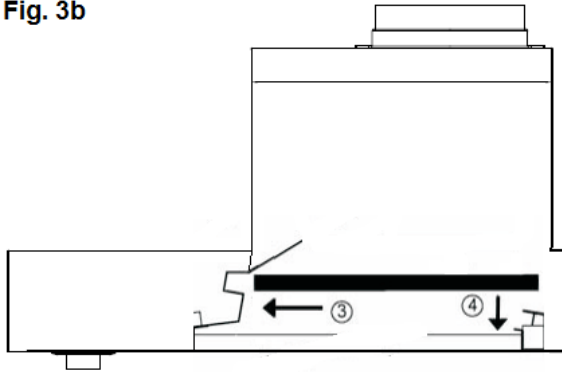
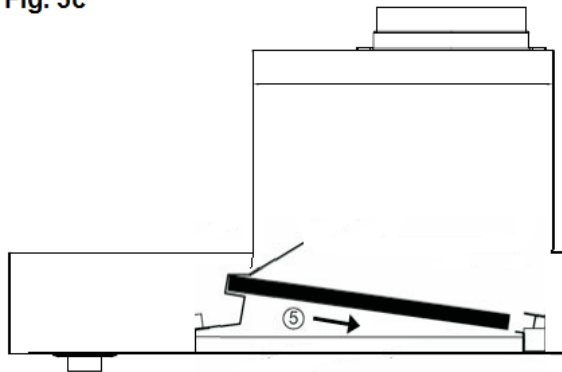

Fig. 3c





Step 1
Twist light ring counter-clock wise to unlock

Step 2
Pull the light upward

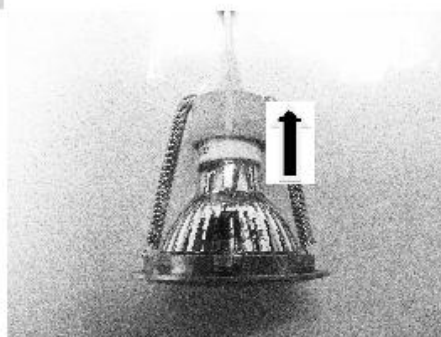

Step 3
Push light to left or right side

Step 4
Remove the light by turning light counter-clock wise



CLEANING & MAINTENANCE**WARNING!!!**

To prevent the possibility of a fire and explosion, do not use flammable liquids or solvents to clean the unit or any of its parts.



Check to make sure all power sources are disconnected before servicing or taking unit apart for cleaning.

1. RANGE HOOD

- a. Use household cleaner to remove grease or dirt from the outer shell of the unit. Spray on wiping cloth or sponge and wipe in the direction of the grain to avoid scratching the unit. (DO NOT SPRAY DIRECTLY ONTO UNIT)
- b. Clean the inner working of the unit periodically to avoid grease build-up.
- c. Do not open control switch panel while the hood is connected to power.
- d. Use stainless steel cleaner to bring back the shine to the unit.

2. BAFFLE FILTERS

- a. Remove baffle filters from unit and place in warm soapy water.
- b. Clean the baffle filters regularly for the most efficient suction power.
- c. Do not drop baffle filters or filler.
- d. Let it soak thoroughly and then clean it with wiping cloth or sponge.
- e. Baffle filters may also be cleaned using residential dishwasher.

TROUBLESHOOTING

WARNING!!!



Check to make sure all power sources are disconnected before starting any troubleshooting. Safety gloves and glasses should be worn when working on the unit. Serious injury or death may occur if safety precautions are not followed.

WS-69 Series	
Light Issue (One light not turning on)	1. Replace defective GU10 Fixture with new fixture.
Filters loose	1. Ensure inside springs are properly expanded
Control Knobs not working correctly	1. Control Knob replacement is required.
Speed levels not working correctly	1. Control Knob replacement may be required. 2. Motor replacement may be required.
Unit lacking smoke intake	1. Make sure a reducer has not been installed. 2. Check ducting for foreign object. 3. Ensure all ducting is properly sealed. 4. Maintenance may be required to increase air-flow
Unit showing no power indication	1. Ensure 120v electrical power source is working correctly.
Unit making humming noise/ motor not starting. /Lights operating correctly.	1. Capacitor replacement is required.

14 PARTS LIST / REPLACEMENT

PARTS LIST / REPLACEMENT

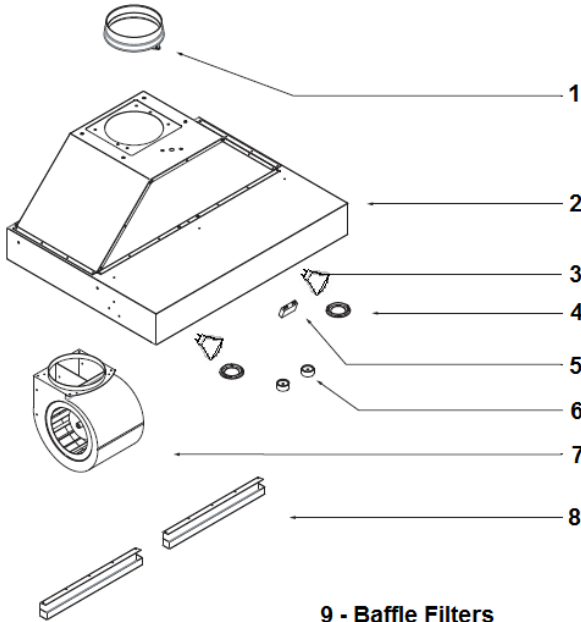

9 - Baffle Filters

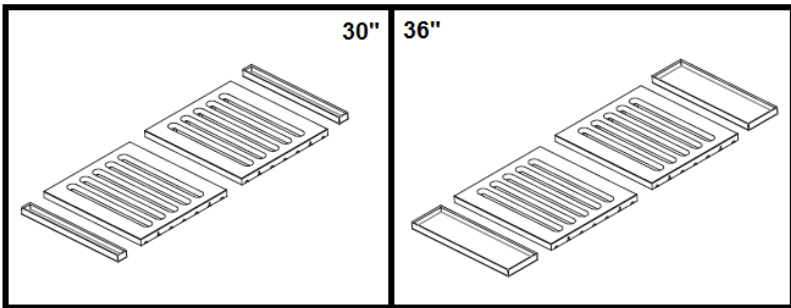

#	Description	#	Description
1	6" round collar	6	Control knob
2	Hood body assembly	7	Motor
3	Halogen / LED lights	8	Oil tray
4	Light cover	9	Baffle filters
5	Capacitor		

WARRANTY / CONTACT US

LIMITED WARRANTY

Windster Hoods Inc. warrants its product against defects in material or workmanship as follows:

Labor: For a period of one (1) year from the date of purchase, if the product is determined to be defective, Windster will attempt to repair the product, at its option, at no charge. After the warranty period, customer must pay for all labor charges. During the "labor" warranty period there will be no charge for any work done on the purchased model. (All labor repairs are limited only to the installation of electrical components.)

Parts: In addition, Windster will supply, at no charge, new or rebuilt replacements in exchange for defective parts for a period of two (2) years. After the warranty period, you must pay for all parts costs. During the "parts" warranty period, there will be no charge for parts

You must provide the serial number of your unit for any replacement parts during the warranty period. This warranty applies to products purchased and serviced in the United States only.

For products purchased in Canada, please contact your local retailer where you purchased the unit for service.

* Windster Hoods, Inc. will attempt to repair malfunctioning units prior to shipping a replacement. In the case that a unit cannot be repaired and must be replaced, Windster Hoods, Inc. will not be held liable for removal / installation fees of the malfunctioning / replacement unit.

WHAT IS NOT COVERED BY MANUFACTURE WARRANTY

1. Damages resulting from any of the following:
 - a. Improper installation or maintenance
 - b. Any repair, modification, alteration or adjustment not authorized by the manufacturer or an authorized service dealer
 - c. Misuse and/or accidents
 - d. Incorrect electric current, voltage or power supply
 - e. Improper setting of any control (Pressing multiple selections at the same time)
 - f. Improper chemical cleaning (commercial or industrial cleaning agents)
2. Products purchased for use in a commercial or industrial setting (such as in a hotel, office, restaurant, or other business)
3. Damage resulting from natural disasters (earthquake, flood, storm, etc.)
4. Aluminum Filters, Baffle Filters, Charcoal Filters, and Oil Cup Filters
5. Light Bulbs

CONTACT US

Windster Hoods, Inc.
5101 Commerce Dr.
Baldwin Park, CA 91706
TEL: (626) 962 – 8600
FAX: (626) 962 – 8669
Toll Free: (877) 350 – 5215
E-mail: Support@windsterhood.com
© Windster Hoods, Inc.
Information subject to change without notice