



GENERAL DESCRIPTION:

Exposed, Battery Powered, Sensor Operated Selectronic™ Urinal Flush Valve for 3/4" top spud urinals.
Inlet includes 3/4" I.P.S. angle stop with back-flow protection, vandal-resistant cap, sweat solder kit, cover tube and wall flange.
Outlet includes 3/4" vacuum breaker with adjustable tailpiece, spud coupling and flange.

PRODUCT FEATURES:

- Electronic flush valve with Selectronic™ proximity system for "Hands Free" operation.
- Self-Cleaning Piston with integral wiper spring prevents clogging and reduces maintenance.
- Piston operation delivers superior flush accuracy and repeatability.
- Fully Mechanical Manual Override Button can operate for an unlimited time without power.
- Valve remains closed and does not need to be reset after loss of power or water pressure.
- Sanitary Flush: Valve automatically flushes after 24 hours of non-use to clean fixture & maintain trap seal.
- Stadium Feature: Valve automatically switches to water savings mode during periods of high usage.
- Sensor & electronic controls are fully enclosed and water resistant.
- Range can be adjusted manually or with optional remote control.
- Chemical resistant EPDM seals are unaffected by chloramines & other chemicals.
- Adjustable tailpiece.
- Factory-installed CR-P2 lithium battery included.
- No external volume adjustment.
- Can be installed left or right handed.

MODEL NUMBER:

- ☐ **6063.025.002** Flush Valve for 3/4" top spud urinals, 0.25 gpf.

OPERATING PRESSURE:

Overall Range: 20-125 psi**
Recommended: 20 psi (Flowing)-80 psi (static)

FLOW REQUIREMENT:

10 gpm (37.9 L/min.)

** Water pressure over 80 psi is not recommended for most plumbing fixtures.

BATTERY LIFE:

200,000 cycles (4 years @ 4000 cycles per month)

ACCESSORIES:

- Cast wall flange (3/4")

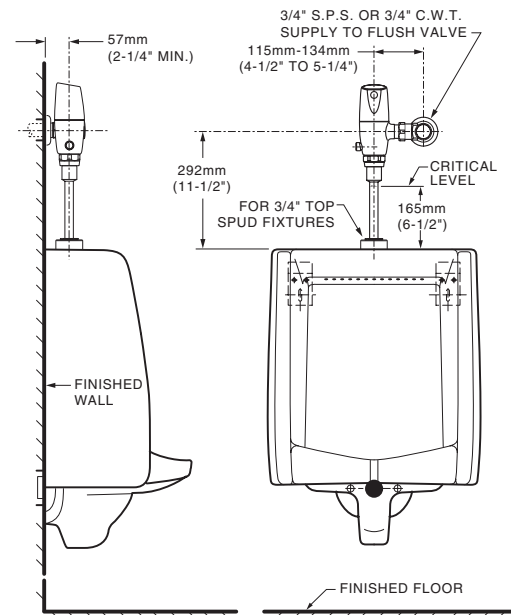

RECOMMENDED SPECIFICATION:

Electronic proximity infrared sensor activated urinal flush valve shall feature self-cleaning piston valve with integral wiper spring in refill orifice to prevent clogging. Includes a fully mechanical manual over-ride that can provide a complete flush without battery power. Includes cast brass valve body and metal cover with chrome finish, vandal resistant stop cap and lithium battery. Angle stop with back-flow protection and vacuum breaker included. 0.25 gpf / 0.9 Lpf Flush valve shall be American Standard Model # 6063.025.002.

LISTINGS:

- ASSE 1037
- ANSI/ASME A112.19.2
- ADA Compliant

Roughing-in Dimensions

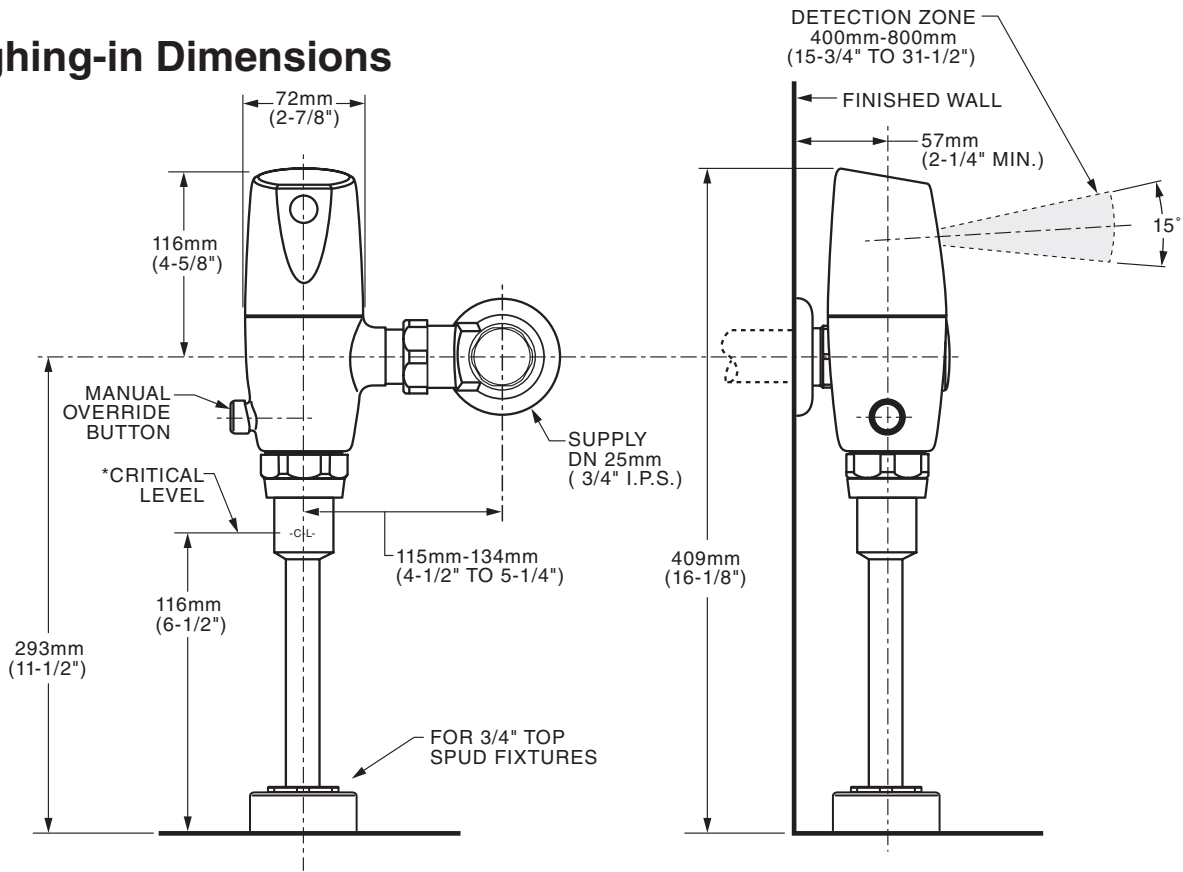

*Note: The Critical Line (-C-L-) on Vacuum Breaker must typically be 6" (152mm) above fixture. Consult Codes for details.

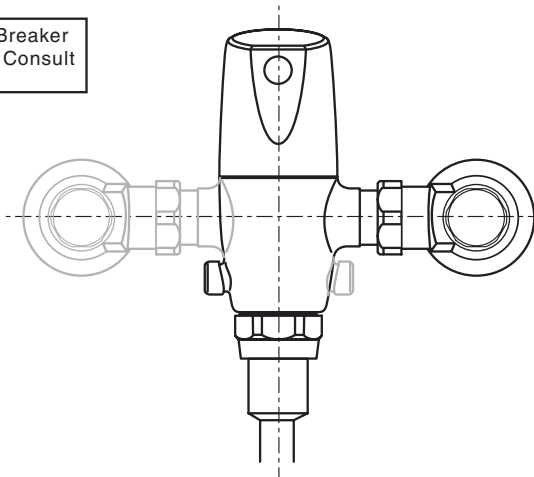

Right or Left Hand Installation

 MEETS THE AMERICANS WITH DISABILITIES ACT GUIDELINES AND ANSI A117.1 REQUIREMENTS FOR ACCESSIBLE AND USABLE BUILDING FACILITIES-CHECK LOCAL CODES