



# **INSTALLATION AND OPERATING INSTRUCTIONS**

## **APUN SERIES UPFLOW ACID NEUTRALIZERS**

### **MODELS:**

**APUN101**

**APUN201**

**APUN301**

**APUN100-LM**

**APUN200-LM**

**Installer, please leave with homeowner.  
Homeowner, retain for future reference.**

INSTR2195 0412







# SAFETY INFORMATION

Read, understand, and follow all safety information contained in these instructions prior to installation and use of the APUN Series Upflow Acid Neutralizer. Retain these instructions for future reference.

**Intended use:**

APUN Series Upflow Acid Neutralizers are intended for use in treating acidic water conditions in homes and have not been evaluated for other uses. These systems are intended for indoor installations near the entry point of a home water line, and must be installed by qualified professional installers according to these installation instructions.

<b><i>EXPLANATION OF SIGNAL WORD CONSEQUENCES</i></b>	
 <b>WARNING</b>	Indicates a potentially hazardous situation, which, if not avoided, could result in death or serious injury and/or property damage.
 <b>CAUTION</b>	Indicates a potentially hazardous situation which, if not avoided, may result in minor or moderate injury and/or property damage.
<b>CAUTION</b>	Indicates a potentially hazardous situation, which, if not avoided, may result in property damage.

 <b>WARNING</b>
<p><b>To reduce the risk associated with choking:</b></p> <ul style="list-style-type: none"> <li>• Do not allow children under 3 years of age to have access to small parts during the installation of this product.</li> </ul>
<p><b>To reduce the risk associated with ingestion of contaminants:</b></p> <ul style="list-style-type: none"> <li>• Do not use with water that is microbiologically unsafe or of unknown quality without adequate disinfection before or after the system.</li> </ul>
<p><b>To reduce the risk of physical injury:</b></p> <ul style="list-style-type: none"> <li>• Shut off inlet water supply and depressurize system as shown in manual prior to service.</li> </ul>
<p><b>To reduce the risk associated with a hazardous voltage:</b></p> <ul style="list-style-type: none"> <li>• If the home electrical system requires use of the cold water system as an electrical safety ground, a jumper must be used to ensure a sufficient ground connection across the Acid Neutralizer System installation piping — refer installation to qualified personnel.</li> <li>• Do not use the system if the power cord is damaged — contact qualified service personnel for repair.</li> </ul>
<p><b>To reduce the risk associated with back strain due to the heavy weight of the various system components:</b></p> <ul style="list-style-type: none"> <li>• Follow safe lifting procedures.</li> </ul>

 <b>CAUTION</b>
<p><b>To reduce the risk associated with skin, eye, and respiratory tract irritation from gravel and neutralizer media during installation:</b></p> <ul style="list-style-type: none"> <li>• Gravel and several types of neutralizer media may be used in this product, depending upon the application. During installation, dust may cause irritation to skin, eyes, and respiratory tract.</li> <li>• Utilize a NIOSH-approved dust filter mask, protective gloves, and appropriate eye protection when handling and pouring gravel and neutralizer media.</li> <li>• To request an MSDS relating to the media shipped with this product, call 203-238-8965 or go to <a href="http://www.3M.com">www.3M.com</a> , select country, and use the search engine to search MSDS. For emergencies, call 800-364-3577 or 651-737-6501 (24 hours).</li> </ul>
<p><b>To reduce the risk associated with skin, eye, and respiratory tract irritation from water treatment chemicals:</b></p> <ul style="list-style-type: none"> <li>• Several types of water treatment chemicals may be used in this product, depending upon the application. During installation and use, exposure may cause irritation to skin, eyes, and respiratory tract.</li> <li>• Utilize a NIOSH-approved dust filter mask, protective gloves, and appropriate eye protection when handling and pouring water treatment chemicals.</li> <li>• To request an MSDS relating to the media shipped with this product, call 203-238-8965 or go to <a href="http://www.3M.com">www.3M.com</a> , select country, and use the search engine to search MSDS. For emergencies, call 800-364-3577 or 651-737-6501 (24 hours).</li> </ul>

## CAUTION

### To reduce the risk associated with property damage due to water leakage:

- **Read and follow** Use instructions before installation and use of this water treatment system.
- Installation and use **MUST** comply with existing state or local plumbing codes. Use flexible tubing connections to connect the valve to household plumbing (as shown in schematic).
- **Protect from freezing**, relieve pressure and drain system when temperatures are expected to drop below 33°F (0.6°C).
- **Do not** install systems in areas where ambient temperatures may go above 110°F (43.3°C).
- **Do not** install on hot water supply lines. The maximum operating water temperature of this Acid Neutralizer System is 110°F (43.3°C).
- **Do not** install if water pressure exceeds 100 psi (689 kPa). If your water pressure exceeds 80 psi (552 kPa), you must install a pressure limiting valve. Contact a plumbing professional if you are uncertain how to check your water pressure.
- **Do not** install where water hammer conditions may occur. If water hammer conditions exist you must install a water hammer arrester. Contact a plumbing professional if you are uncertain how to check for this condition.
- Where a backflow prevention device is installed on a water system, a device for controlling pressure due to thermal expansion must be installed.
- **Do not** use a torch or other high temperature sources near Acid Neutralizer System, cartridges, plastic fittings or plastic plumbing.
- On plastic fittings, never use pipe sealant or pipe dope. **Use PTFE thread tape only**, pipe dope properties may deteriorate plastic.
- Take care when using pliers or pipe wrenches to tighten plastic fittings, as damage may occur if over tightening occurs.
- **Do not** install in direct sunlight or outdoors.
- Mount system in such a position as to prevent it from being struck by other items used in the area of installation.
- Ensure all tubing and fittings are secure and free of leaks.
- **SHUT OFF FUEL OR ELECTRIC POWER SUPPLY TO WATER HEATER** after water is shut off.
- **Do not** install system where water lines could be subjected to vacuum conditions without appropriate measures for vacuum prevention.
- **Do not** install system where water lines could be subjected to vacuum conditions without appropriate measures for vacuum prevention.
- **Do not** apply heat to any fitting connected to Bypass or Control Valve as damage may result to internal parts or connecting adapters.
- Install on a flat/level surface. It is also advisable to sweep the floor to eliminate objects that could pierce the media tank.

### To reduce the risk associated with property damage due to plugged water lines:

- Pay particular attention to correct orientation of control valve. Water flow should match arrow on control valve. The Inlet and Outlet of other water treatment equipment products will vary depending on the control valve brand used.

## IMPORTANT NOTES

- Failure to follow instructions may result in water leakage and will void warranty.

# TABLE OF CONTENTS

<b>SECTION</b>	<b>DESCRIPTION</b>
1	HOW A NEUTRALIZER WORKS
2	INSTALLATION
3	MAINTENANCE
4	TROUBLESHOOTING
5	SPECIFICATIONS
6	COMPONENT PARTS
7	LIMITED WARRANTY

## SECTION 1: HOW A NEUTRALIZER WORKS

The low pH (acid) water passes through a special limestone neutralizing media and slowly dissolves the media raising the pH to approximately 7 units (neutral) or higher. Periodic media replenishment is therefore required. The frequency and amount of media replenishment depends on the volume of water used and how acidic the water is before treatment. The lower the pH (acidity) of the water being treated, the greater the attrition rate of the media and the slower the water should pass through the bed. The unit should be sized according to the level of pH and existing flow rate. Your dealer can provide an estimate of your replenishment requirements.

APUN Series Upflow Acid Neutralizers virtually eliminate the possibility of media bed “cementing” because the water to be treated actually “upflows” through the neutralizer media bed! This procedure requires NO electricity or backwashing.

A large fill-port permits easy replenishment of the “sacrificial” neutralizing media by the homeowner or a service technician.

There are different media types available which can be used in this APUN Series Upflow Acid Neutralizer System. Each is designed to improve a particular aesthetic problem. None of them should be used to make non-potable water safe to drink. The following descriptions indicate not only what the media is designed to do, but also points out their limitations.

### Neutralizer Blend

Neutralizer media is typically a blend of calcium carbonate and magnesium oxide. This media is used to elevate the pH of acid water and is generally used when the pH is approximately 5.5 - 6.0 units. The neutralizer media dissolves when water with a low pH passes through. The blend is used to take advantage of the fast, vigorous pH adjusting capabilities of magnesium oxide and the slow, long-lasting capabilities of the calcium carbonate. Neutralizer is typically not recommended when the pH of the raw water is below 5.5 units, because the dissolve rate would be high and thus constant maintenance of the APUN Series Acid Neutralizer System would be necessary. In these cases contact our Customer Service Department at 1-800-222-7880 for recommendations.

### IMPORTANT NOTE

Since the neutralizer media dissolves as it elevates pH level, it will increase the hardness of your water. If your dwelling contains a tankless water heater, a water softener must be installed after the APUN Series Upflow Acid Neutralizer System to help prevent the heater coil from plugging with hardness material.

### Calcium Carbonate

Calcium carbonate can be used when only a slight pH adjustment is required (typically 6.0 to 6.8 units). Calcium carbonate is sacrificial (dissolves) when adjusting pH and will thus increase hardness as well. Replenishment will be required periodically, once again depending on raw water pH and water consumption.

### IMPORTANT NOTE

Since both calcium carbonate and magnesium oxide increase hardness of your water, if your dwelling contains a tankless water heater, it is recommended that a water softener be installed after the APUN Series Upflow Acid Neutralizer System to help prevent the heater coil from plugging with hardness material.

## SECTION 2: INSTALLATION

### CAUTION

**To reduce the risk associated with property damage due to water leakage:**

- Installation and use **MUST** comply with existing state or local plumbing codes.
- **SHUT OFF FUEL OR ELECTRIC POWER SUPPLY TO WATER HEATER** after water is shut off.

#### Step 1

Refer to Typical Installation Sequence (Figure 1) for correct placement of neutralizer in relationship to other water treatment devices. Installation location is critical because it may change the effectiveness of other products.

#### Step 2

Shut off all water at main supply. On a private well system, turn off power to pump and drain pressure tank. Make certain pressure is relieved from complete system by opening nearest faucet to drain system. Shut off fuel supply to hot water heater.

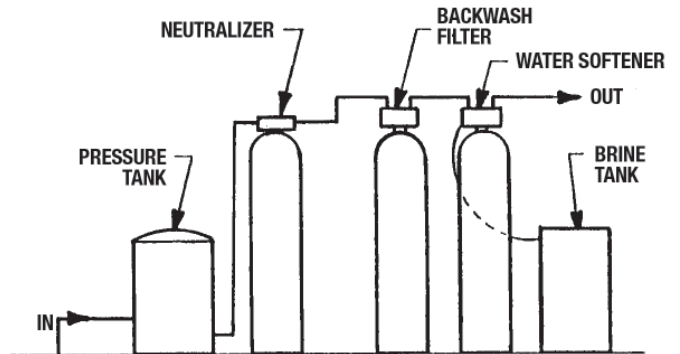

**Figure 1. TYPICAL INSTALLATION SEQUENCE**

#### Step 3

Gently rock tank from side to side in order to make sure the gravel shipped inside the tank is spread across the bottom of the tank (APUN301 only). Gravel may have shifted during shipping and handling. Locate the bypass valve and connect to the head assembly. Assemble the connection fittings and connect to the bypass valve. Tighten the connection nuts on both the bypass and connections fittings by hand only. Close both the inlet and outlet valves on the bypass and leave in closed position until instructed otherwise.

### CAUTION

**To reduce the risk associated with property damage due to water leakage:**

- Installation and use **MUST** comply with existing state or local plumbing codes.
- Mount system in such a position as to prevent it from being struck by other items used in the area of installation.
- Install on a flat/level surface. It is also advisable to sweep the floor to eliminate objects that could pierce the media tank.

**To reduce the risk associated with property damage due to plugged water lines:**

- Pay particular attention to correct orientation of control valve. Water flow should match arrow on control valve. The inlet and outlet of other water treatment equipment products will vary depending on the control valve brand used.

#### Step 4

Refer to diagram (Figure 2) for recommended plumbing procedure. Cut main supply line as required to fit plumbing to the inlet and outlet of neutralizer. Use thread tape on nipple threads, as most pipe thread pastes will cause deterioration of plastic fittings. Hold nipples with wrench while attaching plumbing. **DO NOT OVERTIGHTEN.** If a boiler drain (not supplied) is to be connected, be sure to install it on the outlet side of the APUN Series Upflow Acid Neutralizer System.

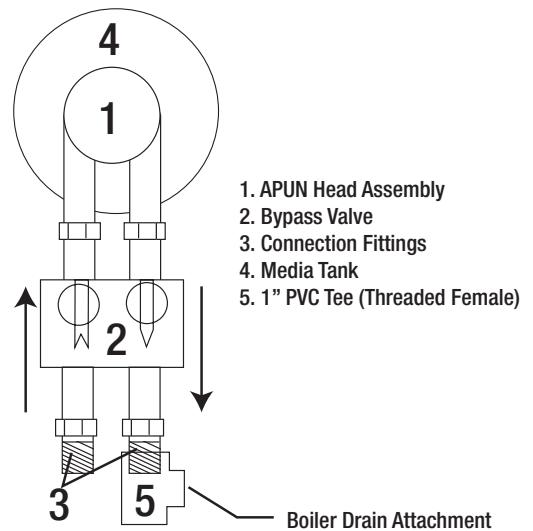

**Figure 2. RECOMMENDED PLUMBING PROCEDURE**

**Step 5**

After completion of plumbing connections, remove fill-port cap using wrench provided and pour neutralizer media into mineral tank using funnel provided (Figure 4). DO NOT fill tank above the line on the side of the media tank.

**IMPORTANT NOTE**

Overfilling the tank can result in neutralizer media entering the service lines. You may have been provide more media than is required for the initial fill. Save this extra media for future replenishment.

**Step 6**

Open inlet valve and then turn water supply back on. Using a garden hose or bucket, fill unit with water through fill-port. Replace fill-port cap.

**Step 7**

Attach a garden hose to boiler drain (if installed) on outlet of the APUN Series Upflow Acid Neutralizer System. Discharge of hose should be into a bucket or drain. Open boiler drain and slowly open inlet valve to flush the APUN Series Upflow Acid Neutralizer System. Discharge water from hose will be milky white due to fines generated during shipping and handling. Very fine particles of neutralizer media may also be observed in the water. If “sand” like particles are observed, reduce flush flow rate and then gradually increase. Continue to flush until discharge water runs clear.

**Step 8**

Upon completion of flushing, close boiler drain and bypass valve and open outlet valve.

**Step 9**

Installation is now complete. Turn water heater back on and test treated water with commercially available pH test kit.

**IMPORTANT NOTES:**

- If the home utilizes a tankless water heater, it is recommended that a water softener be installed following the the APUN Series Upflow Acid Neutralizer System.
- If the pH is initially over corrected, the inlet bypass can be partially closed to mix untreated water with treated water to achieve the desired level.

## SECTION 3: MAINTENANCE

The media in this the APUN Series Upflow Acid Neutralizer System is sacrificial, therefore it must be replenished periodically. The frequency is dependent on the raw water pH and your water consumption habits. The lower the pH and the higher the water usage, the more frequently replenishment will be required. One easy way of determining when to replenish is by placing a mark on the outside of the tank at the level of the media when first installed. Periodically shine a bright light through the tank and compare the current level to the mark, if it is down more than two (2) inches, add media to the mark. If you are unable to see through the tank, remove the fill-port cap and measure down to the top of the media. The tank should be 2/3 full. If not, add media.

### REPLENISHING MEDIA:

- 1) Close inlet and outlet valves. Open bypass valve so untreated water can still be used during the replenishment operation.
- 2) Open boiler drain to relieve pressure. Remove fill-port cap using wrench provided, some water will drain out of the fill-port opening. Use a flexible tube to siphon approximately two gallons of water from the tank.
- 3) Using the funnel provided, add the required amount of media, not to exceed the indicated line on the media tank. A bright light may be placed behind the tank to observe the media level.
- 4) Refer to Steps 8-9 in Section 2 for flushing instructions to complete the replenishment operation.

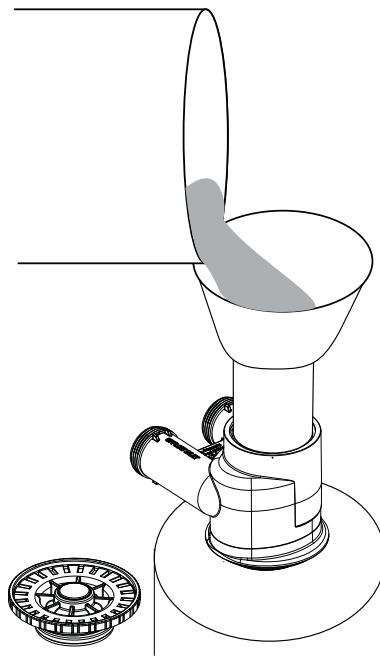

**Figure 4. ADDITION OF NEUTRALIZER MEDIA**

Add media through fill-port using funnel



## SECTION 4: TROUBLESHOOTING

Problem	Possible Solutions
A. Neutralizer overcorrects upon installation or after replenishment.	1. The inlet bypass can be partially closed to allow untreated and treated water to mix to obtain desired pH level. Periodically test treated water pH and open bypass valve when pH begins to drop.
B. Neutralizer fails to increase pH upon installation.	1. Make sure bypass valve is closed. 2. Test water or have it tested via third party. If high hardness or total dissolved solids (TDS), seek alternate means of treatment such as feeding a solution of soda ash or caustic soda. In these cases contact our Customer Service Department at 1-800-222-7880 for recommendations.
C. Neutralizer fails to increase pH after being in service.	1. Check filter bed for cementing or channeling. Break channeling or cementing with stiff rod or tubing.
D. Excessive pressure drop.	1. Check untreated water for sediment, silt or sand. Install sand trap or multiple cartridge filter prior to neutralizer.

### IMPORTANT SERVICING NOTE:

Under normal circumstances removal of the fill-port head assembly should not be required. However, if it must be removed, disconnect the plumbing attached to the bypass valve first. Then, rotate the fill-port head assembly to the left or counter-clockwise. Before attempting any disassembly, pressure should be relieved by shutting off water to the system and opening a faucet. Upon reassembly, all o-rings should be lubricated with silicone grease. Reattach fill-port head assembly by rotating to the right or clockwise until fill-port head assembly is seated to the tank hand tight. Reconnect the plumbing to the bypass valve.

## SECTION 5: SPECIFICATIONS

Model Number	Media (Cu. Ft.)	Pipe Size	Dimensions		Maximum Flow Rate*
			Diameter	Height	
APUN101	1.0	1 in. (2.54 cm)	10 in (25.4 cm)	63 in (160.0 cm)	6 gpm (22.7 lpm)
APUN201	2.0	1 in. (2.54 cm)	12 in (30.5 cm)	68 in (132.1 cm)	7 gpm (26.5 lpm)
APUN301	3.0	1 in. (2.54 cm)	14 in (35.6 cm)	76 in (193.0 cm)	12 gpm (45.4 lpm)
APUN100-LM	None included	1 in. (2.54 cm)	10 in (25.4 cm)	63 in (160.0 cm)	6 gpm (22.7 lpm)
APUN200-LM	None included	1 in. (2.54 cm)	12 in (30.5 cm)	68 in (132.1 cm)	7 gpm (26.5 lpm)

Maximum operating temperature 110°F (43.3°C); Maximum operating pressure 20-100 psi. Specifications subject to change without notice.

#### NOTES:

\* The lower the pH (acidity) of the water being treated, the greater the attrition rate of the media and the slower the water should pass through the bed. The unit should be sized according to the level of pH and existing flow rate.

## SECTION 6: COMPONENT PARTS

Ref Number	Description	APUN100-LM	APUN101	APUN200-LM	APUN201	APUN301
1	Upflow Head (Includes Fill-port)	6238131	6238131	6238131	6238131	6238131
2	Media Tank w/Base	6236001-1044	6236001-1044	6236001-1252	6236001-1252	MTP1465B
3	Upflow Distributor Tube	6236435	6236435	6236435	6236435	DF37-69
4	Media, Calcium carbonate	N/A	C-050P	N/A	C-050P (x4)	C-050P (x6)
5	Gravel, 1/4 x 1/8	N/A	QC-18	N/A	QC-22	QC-22
6	Funnel	U1006	U1006	U1006	U1006	U1006
Not Shown	Bushing, 2 1/2-8 x 4-8	---	---	---	---	2752-2
Not Shown	1" PVC Tee	TEEPVCTHR003	TEEPVCTHR003	TEEPVCTHR003	TEEPVCTHR003	TEEPVCTHR003

Items Not Shown	
Description of Item	Part Number
Wrench	V3193-01
Bypass Valve	V3006
Connection Fittings	V3007-02

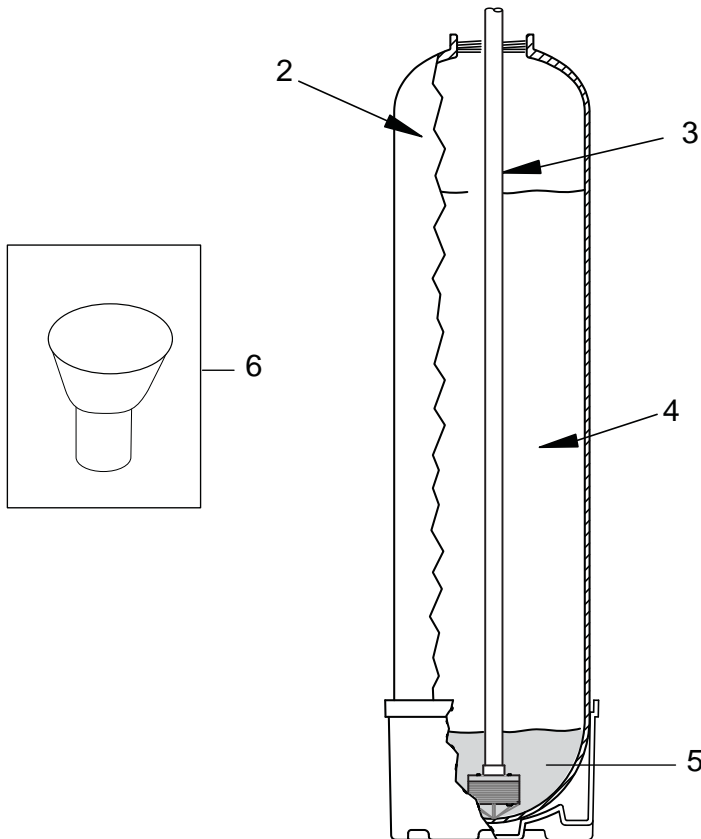
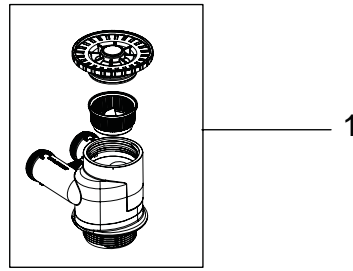

**SECTION 6: PARTS**  
**COMPONENT PARTS LIST**  
**Bypass Valve (Part Number V3006)**

Drawing No.	Order No.	Description	Quantity
1	V3151	Nut 1" Quick Connect	2
2	V3150	Split Ring	2
3	V3105	O-ring 215	2
4	V3145	Bypass 1" Rotor	2
5	V3146	Bypass Cap	2
6	V3147	Bypass Handle	2
7	V3148	Bypass Rotor Seal Retainer	2
8	V3152	O-ring 135	2
9	V3155	O-ring 112	2
10	V3156	O-ring 214	2

**V3191-01 Vertical Adapter Assembly**

Order No.	Description	Quantity
V3151	Nut 1" Quick Connect	2
V3150	Split Ring	2
V3105	O-ring 215	2
V3191	Vertical Adapter	2

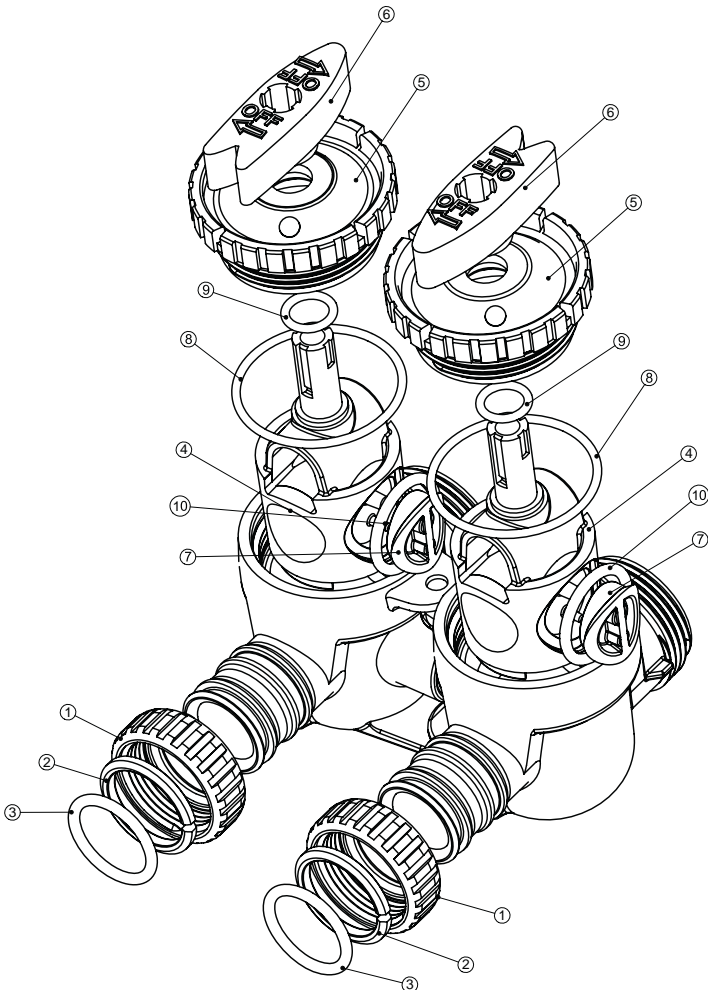

**OPTIONAL FITTING**  
**Order No: V3007-02**  
**Description: Fitting 1" Brass Sweat Assembly**

Drawing No.	Order No.	Description	Quantity
1	V3151	Nut 1" Quick Connect	1
2	V3150	Split Ring	1
3	V3105	O-ring 215	1
4	V3188	Fitting 1" Brass Sweat Assembly	1

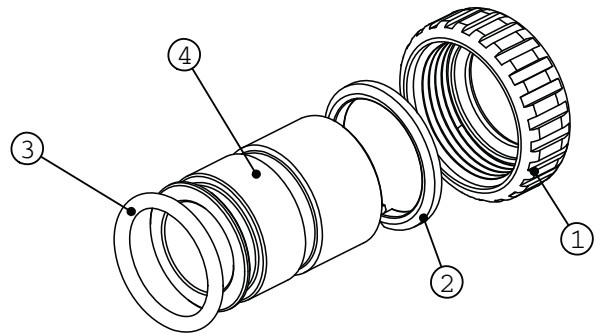

## Section 7: LIMITED WARRANTY

**Limited Warranty:** 3M Purification Inc. warrants this Product to be free from defects in material and workmanship during normal use for the warranty period set forth below. The warranty period commences from the date of purchase. This warranty does not cover failures resulting from abuse, misuse, alteration or damage not caused by 3M Purification Inc. or failure to follow installation and use instructions. No warranty is given as to the service life of any filter cartridge, membrane, or media as it will vary with local water conditions and water consumption.

**3M MAKES NO OTHER WARRANTIES OR CONDITIONS, EXPRESS OR IMPLIED, INCLUDING, BUT NOT LIMITED TO, ANY IMPLIED WARRANTY OR CONDITION OF MERCHANTABILITY OR FITNESS FOR A PARTICULAR PURPOSE OR ANY IMPLIED WARRANTY OR CONDITION ARISING OUT OF A COURSE OF DEALING, CUSTOMER OR USAGE OF TRADE.**

If the Product is found defective within the warranty period, your exclusive remedy and 3M Purification Inc.'s sole obligation shall be, at 3M Purification Inc.'s option, to replace or repair the Product or refund the purchase price of the Product. This warranty does not cover labor. The remedy stated in this paragraph is Customer's sole remedy and 3M Purification Inc.'s exclusive obligation.

**Warranty Period:**

- One (1) year on the entire product unit
- Five (5) years on the media tank only (does not include internal component parts)
- Five (5) years on the fill-port assembly
- Five (5) years on salt storage container and components\*

**Limitation of Liability:** 3M Purification Inc. will not be liable for any loss or damage arising from this 3M Purification Inc. product, whether direct, indirect, special, incidental, or consequential, regardless of the legal theory asserted, including warranty, contract, negligence or strict liability. Some states and countries do not allow the exclusion or limitation of incidental or consequential damages, so the above limitation or exclusion may not apply to you.

**Warranty Claims:**

To obtain warranty service, call 1-800-222-7880 or mail your request to: 3M Purification Inc., 400 Research Parkway, Meriden, CT 06450. Proof of purchase (original sales receipt) must accompany the warranty claim, along with a complete description of the Product, model number and alleged defect. **This warranty gives you specific legal rights, and you may have other rights which may vary from state to state, or country to country.**

\* Water Softeners only



**3M Purification Inc.**  
400 Research Parkway  
Meriden, CT 06450  
1-800-222-7880  
www.3Mpurification.com

Aqua-Pure is a trademark of 3M Company used under license.  
3M is a trademark of 3M Company.  
© 2012 3M Company. All rights reserved.