

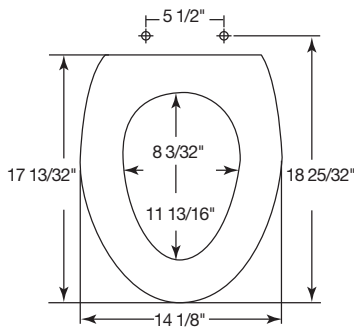

# RESIDENTIAL MOLDED WOOD SEATS

## MODEL 585BR/OR/MB

- ELONGATED SEAT, CLOSED FRONT WITH COVER
- MOLDED WOOD
- BRASS, OIL-RUBBED BRONZE OR MATTE BLACK METAL HINGES



Ring thickness is 1/2"  
Ring thickness including the bumper is 1-1/16"  
Height of seat with cover is 1-7/8"

Seats shall be 585BR/OR/MB as manufactured by Church Seats. Seats shall be molded wood, multi-coat enamel finish with closed front and cover to fit elongated bowl. Color matched bumpers. Available in Brass, Oil-Rubbed Bronze or Matte Black hinges to match bath hardware. Metal hinges offer a stylish alternative to traditional plastic hinges and they will not tarnish or corrode. Color to be \_\_\_\_\_. (specify white or fixture manufacturer's color) Hinge finish to be \_\_\_\_\_. (specify hinge finish)

