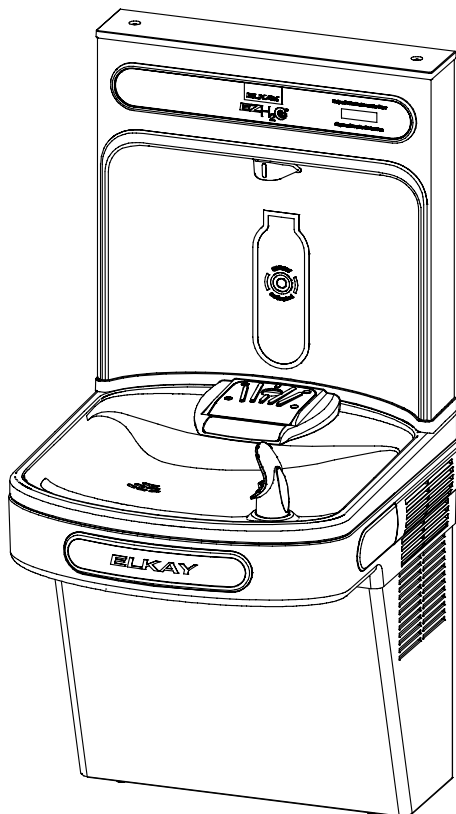




INSTALLATION, CARE & USE MANUAL

EZWSRK -EZH2O™ RETRO-FIT BOTTLE FILLING UNIT



IMPORTANT

THIS IS AN INDOOR APPLICATION ONLY.
ALL SERVICE TO BE PERFORMED BY AN
AUTHORIZED SERVICE PERSON.

TOOLS REQUIRED

BUT NOT PROVIDED:

SAFETY GLASSES
GLOVES
1-3/8" HOLE PUNCH (PROVIDED)
1/2" DRILL BIT
ELECTRIC DRILL
3/4" WRENCH OR CRESCENT WRENCH
5/16" NUT DRIVER
UTILITY KNIFE
TAPE MEASURE
PENCIL
CENTER PUNCH
1/2" SOCKET & RATCHET WRENCH
5/32" ALLEN WRENCH
7/64" ALLEN WRENCH

IMPORTANT! INSTALLER PLEASE NOTE.

THE GROUNDING OF ELECTRICAL EQUIPMENT SUCH AS TELEPHONE, COMPUTERS, ETC. TO WATER LINES IS A COMMON PROCEDURE. THIS GROUNDING MAY BE IN THE BUILDING OR MAY OCCUR AWAY FROM THE BUILDING. THIS GROUNDING CAN CAUSE ELECTRICAL FEEDBACK INTO A FOUNTAIN, CREATING AN ELECTROLYSIS WHICH CAUSES A METALLIC TASTE OR AN INCREASE IN THE METAL CONTENT OF THE WATER. THIS CONDITION IS AVOIDABLE BY USING THE PROPER MATERIALS AS INDICATED. ANY DRAIN FITTINGS PROVIDED BY THE INSTALLER SHOULD BE MADE OF PLASTIC TO ELECTRICALLY ISOLATE THE FOUNTAIN FROM THE BUILDING PLUMBING SYSTEM. WE SUGGEST THAT THE BOTTLE FILLING STATION AND WATER COOLER BE PROTECTED BY A GROUND FAULT CIRCUIT INTERRUPTER (GFCI).

INSTALLER

EZWSR Bottle Fillers are among the easiest to install on the market today. To insure you install these models easily and correctly, PLEASE READ THESE SIMPLE INSTRUCTIONS BEFORE STARTING THE INSTALLATION. CHECK YOUR INSTALLATION FOR COMPLIANCE WITH PLUMBING, ELECTRICAL, AND OTHER APPLICABLE CODES. After installation, leave these instructions with the Cooler for future reference.

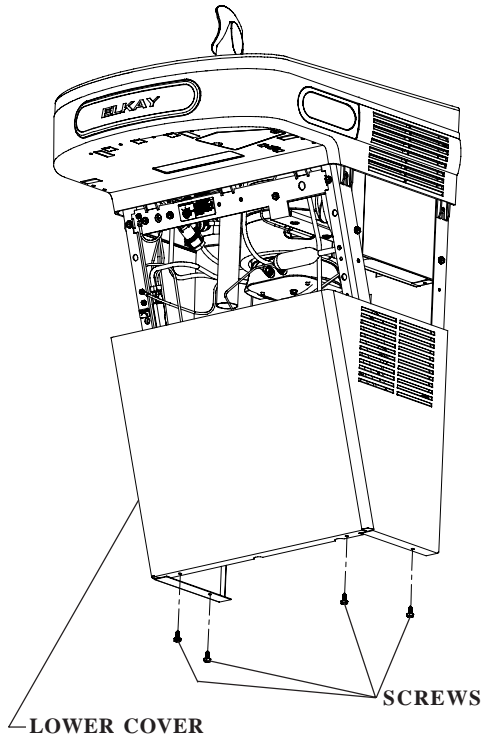
WATER COOLER PREPARATION

Fig. 1

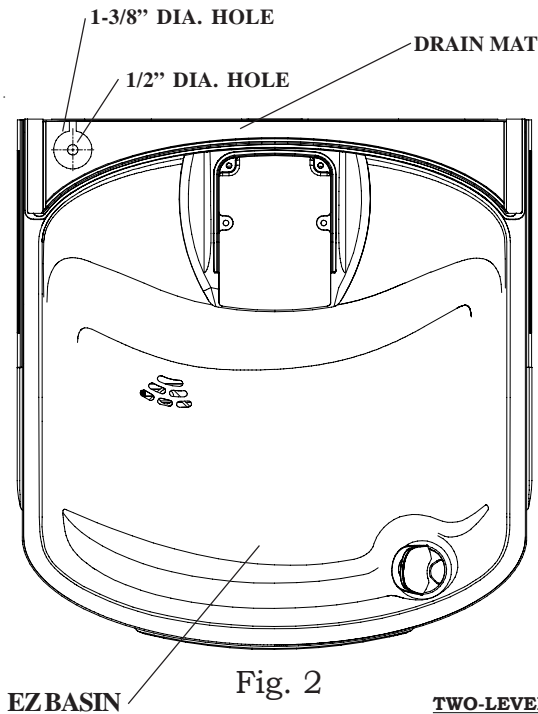


Fig. 2

TWO-LEVEL MODIFICATION OF WATER SYSTEM

NOTE: Two-Level water systems are already plumbed for pressurization.

STANDARD TWO-LEVEL MODELS

Follow instruction 2 thru 4 under "Pressurization of water system" to attach filter to water system. The non-refrigerated side must be removed from the wall in order to remove the basin assy. and install the filter head assy.

- 1) Remove the Two-Level Cover Plate from the right hand side of the non-refrigerated unit in order to access the rear Basin Assy. screw.
- 2) Cut poly tube "H" between the existing tee and the solenoid valve of the L.H. unit.
- 3) Insert supplied 1/4" Tee in water line "H" where it was just cut (See Fig. 4A).

TWO-LEVEL REVERSED MODELS

Follow instruction 2 thru 4 under "Pressurization of water system" to attach filter to water system. The non-refrigerated side must be removed from the wall in order to remove the basin assy. and install the filter head assy.

- 1) Remove the Bi-Level Cover Plate from the left hand side of the refrigerated unit in order to access the rear Basin Assy. screw (See Fig 5).
- 2) Cut poly tube "H" approximately 3" from the left side of the existing tee.
- 3) Insert supplied 1/4" tee in water line "H" where it was just cut.

1) Remove lower front panel of watercooler by removing the four (4) screws from the bottom of cooler. (See FIG. 1) **NOTE:** For Two Level Models the Bottle Filling Unit should be mounted to the higher unit. Both lower front panels and basin assemblies will need to be removed.

1a) For units with model no's. ending with 1, 1A, 2 or 3 these units will need to be removed from the wall in order to remove the basin assembly(s).

2) Power OFF circuit that the water cooler is connected to by switching the circuit breaker to the "OFF" position or by removing the fuse to the circuit. Remove the water cooler plug from the outlet and shut off water supply.

3) Locate Drain Mat and place on back of EZ cooler basin to use as a template.

4) Locate 1-3/8" diameter hole on left side of Drain Mat (See FIG. 2). Mark center of hole on basin with pencil. Remove the drain mat from the cooler

(DO NOT THROW AWAY! It will be needed for bottle filler installation).

5) Remove Basin Assembly by loosening four (4) screws two on each side of cooler as shown in Fig. 5. Disconnect water line "A" from bubbler at the evaporator tank (See Fig. 3). **NOTE:** When disconnecting water lines use a container to catch any water running out of the lines. Disconnect basin assembly from drain trap. Lift basin assembly straight up to remove, and disconnect two wires from push bar switches. (Note: This will allow easier assembly of water filter to unit and pressurization of the unit.)

5a) For units referenced in step "1a". Remove Basin Assembly by loosening four (4) screws two on each side of cooler as shown in Fig. 5. Remove 2 screws from top back of unit to remove the "L" bracket. Remove 1 screw from left side of cross brace in front of unit that retains the drain support. Disconnect water line "A" from regulator at the evaporator tank (See Fig. 3B). **NOTE:** When disconnecting water lines use a container to catch any water running out of the lines. Disconnect basin assembly from drain trap. Lift basin assembly straight up to remove, and disconnect two wires from push bar switches.

PRESSURIZATION OF WATER SYSTEM

NOTE: This procedure MUST be performed on ALL SINGLE EZ WATER COOLERS or the bottle filling unit WILL NOT perform properly!

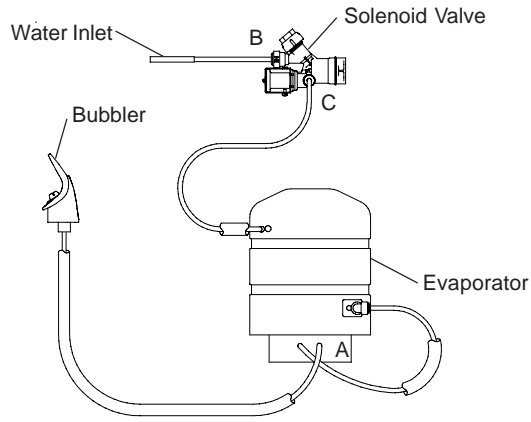
1) Remove water inlet (B) and outlet (C) from solenoid valve (See Fig. 3 or 3B). **NOTE:** When disconnecting water lines use a container to catch any water running out of the lines.

2) CAUTION: If supply pressure will ever exceed 100 psi, install a pressure regulator to limit the inlet pressure to the filter to 100 psi or below. DO NOT ATTACH HOT WATER LINE TO FILTER.

3) Reconnect the water inlet to the inlet of the evaporator (See Fig. 4 or 4B).

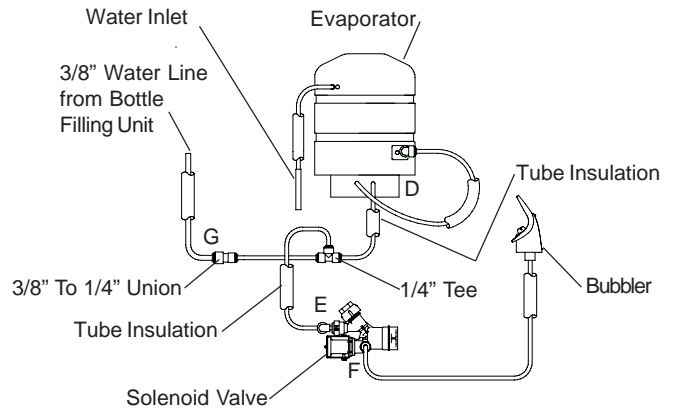
4) Cut a 12" long piece of poly tube (besure to insulate poly tube with supplied insulation tubing) and insert one end into the outlet side of the evaporator "D" (See Fig. 4 or 4B), connect Tee to other end of tube.

5) Cut a 12" long piece of poly tube (besure to insulate poly tube with supplied insulation tubing) and insert into the Tee and the other end into the inlet side of the solenoid valve "E" (See fig. 4 or 4B).



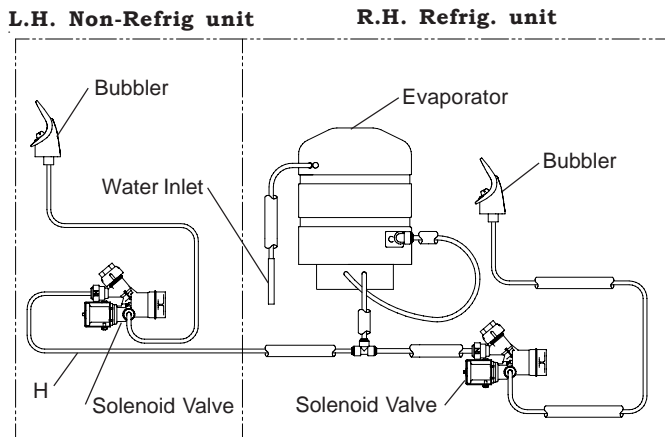
EZ Non-Pressurized Plumbing Diagram

Fig. 3



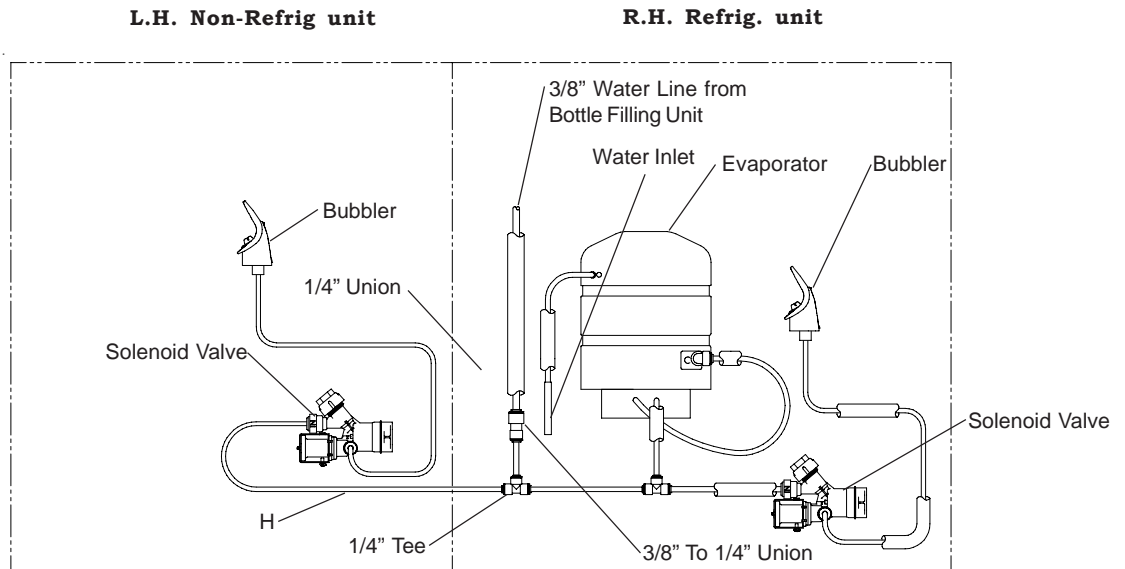
EZ Plumbing Diagram after Pressurization Modifications

Fig. 4



Standard EZ Two Level Pressurized Plumbing Diagram

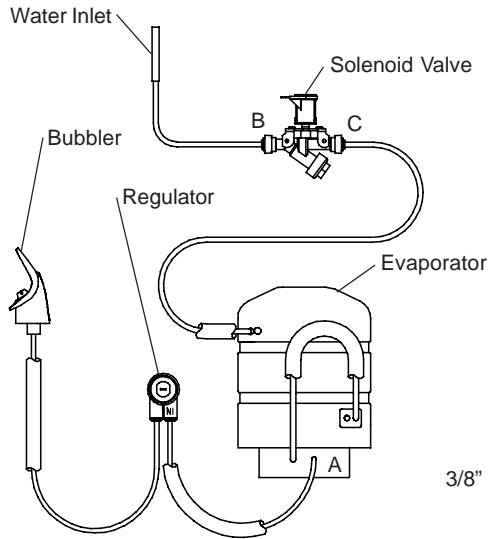
Fig. 3A



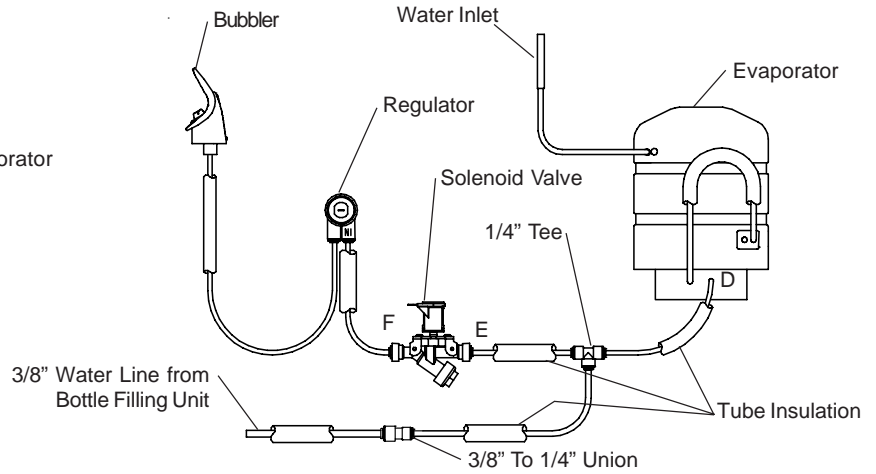
EZ Two Level Plumbing Diagram after Bottle Filler Water Line Addition

Fig. 4A

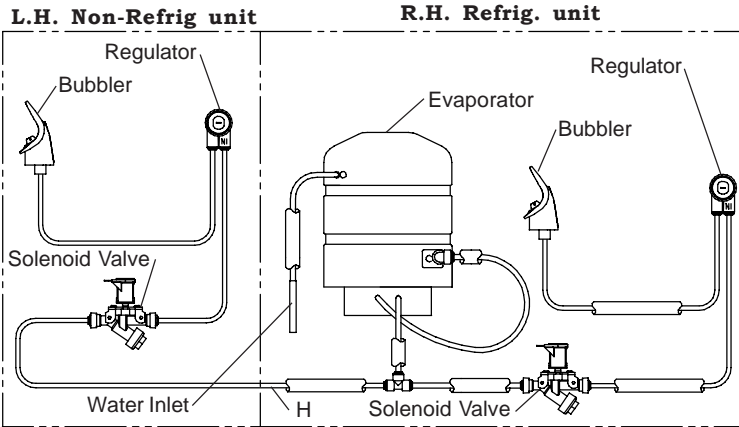
Plumbing Diagrams for EZ Coolers w/ model no's ending with 1, 1A, 2, & 3



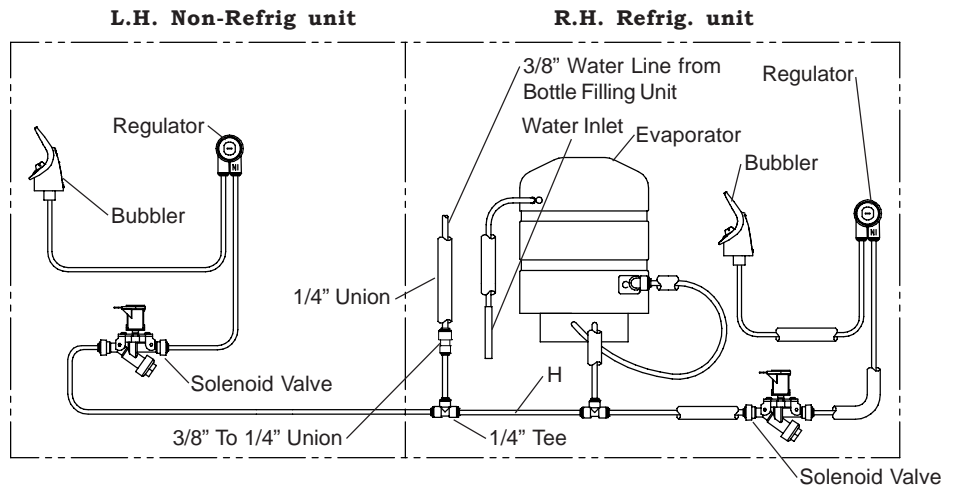
EZ Non-Pressurized Plumbing Diagram
Fig. 3B



EZ Plumbing Diagram after Pressurization Modifications
Fig. 4B

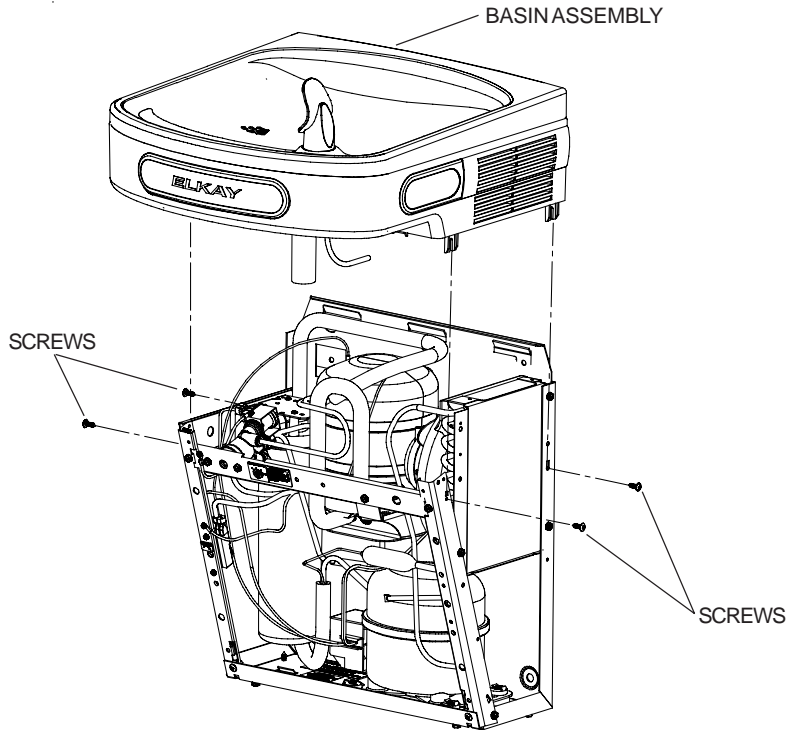


Standard EZ Two Level Pressurized Plumbing Diagram
Fig. 3C



EZ Two Level Plumbing Diagram after Bottle Filler Water Line Addition

Fig. 4C



Basin Assembly Removal

Fig. 5

BASIN ASSEMBLY PREPARATION

- 1) Center punch 1/2" hole location on basin prior to drilling the hole in top of cooler basin using an adequate drill and 1/2" drill bit capable of drilling through stainless steel (See FIG. 2).
- 2) Locate 1-3/8" knockout punch tool (provided). Unscrew the top half from the bottom half of the tool.
- 3) With one hand holding the bottom half, and the other hand holding the top half of the punch, insert the top half bolt through the 1/2" hole in basin, then reach inside the basin assembly underneath the cooler basin with the bottom half and thread it on to the top half bolt. Tighten bottom half on punch until finger tight.
- 4) Using 3/4" wrench or crescent wrench tighten the bolt on top half of punch until basin gives way creating the larger hole. Note tool will turn hard.
- 5) Once hole is made tool may be discarded.
- 6) Locate plastic bushing (provided) and place in basin hole by pushing into hole until it snaps into place. This bushing protects the water line, wire(s), and power cord from sharp edge of basin. **This part must be used.**
- 7) **For Single Model installations:** Attach the purple wire (supplied), on to the open terminal of the solenoid valve.
- 7a) **For Two-Level Model installations:** Attach the purple wire (supplied), on to the open terminal of the solenoid valve to the unit that the basin hole was punched in for the Bottle Filling Station. Attach the yellow wire (supplied), on to the open terminal of the solenoid valve of the other unit.
- 8) Reassemble Basin Assembly back on to unit. Connect the bubbler water line to the outlet side of the solenoid valve "F" (See Fig.4), be sure to reconnect the black wire from the pushbar assembly back to the purple or yellow piggyback terminal on the solenoid valve. and the other black wire back to the cold control or power cord (non-refrigerated unit), fish the purple and/or yellow wire(s) up through basin hole and reattach drain to the trap. Retighten the 4 screws two per side see Fig. 5.

FOR UNITS WITH MODEL NO'S. ENDING IN 1, 1A, 2, & 3

- 8a) Remove the white wire from the cold control and connect it to the power cord white wire. Reassemble Basin Assembly back on to unit. Connect the regulator water line to the outlet side of the solenoid valve "F" (See Fig.4B), be sure to reconnect one black wire from the pushbar assembly back to the purple or yellow piggyback terminal on the solenoid valve. Connect the other black wire from the pushbar assembly to the piggyback on the cold control. Fish the purple and/or yellow wire(s) up through basin hole and reattach drain to the trap and reinstall drain support screw to front cross brace. Reinstall "L" bracket to top back of unit with the 2 screws it was mounted with. Retighten the 4 screws two per side see Fig. 5.

ALL STANDARD TWO-LEVEL MODELS

After completing instructions 1 thru 8 or 8a from above on the non-refrigerated side. Reinstall basin assembly to the non-refrigerated side, re-attach wiring, bubbler tube (or regulator tube) to solenoid valve and reinstall the two level cover plate to the left side of the unit. Reinstall non-refrigerated unit to wall and reinstall drain.

ALL TWO-LEVEL REVERSED MODELS

After completing instructions 1 thru 8 or 8a from above on the refrigerated side. Reinstall basin assembly to the non-refrigerated side, re-attach wiring, bubbler tube (or regulator tube) to solenoid valve and reinstall the two level cover plate to the left side of the unit. Reinstall non-refrigerated unit to wall and reinstall drain.

OPERATION OF QUICK CONNECT FITTINGS

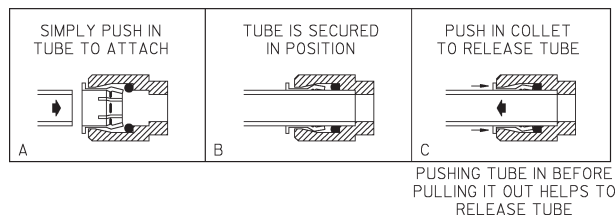
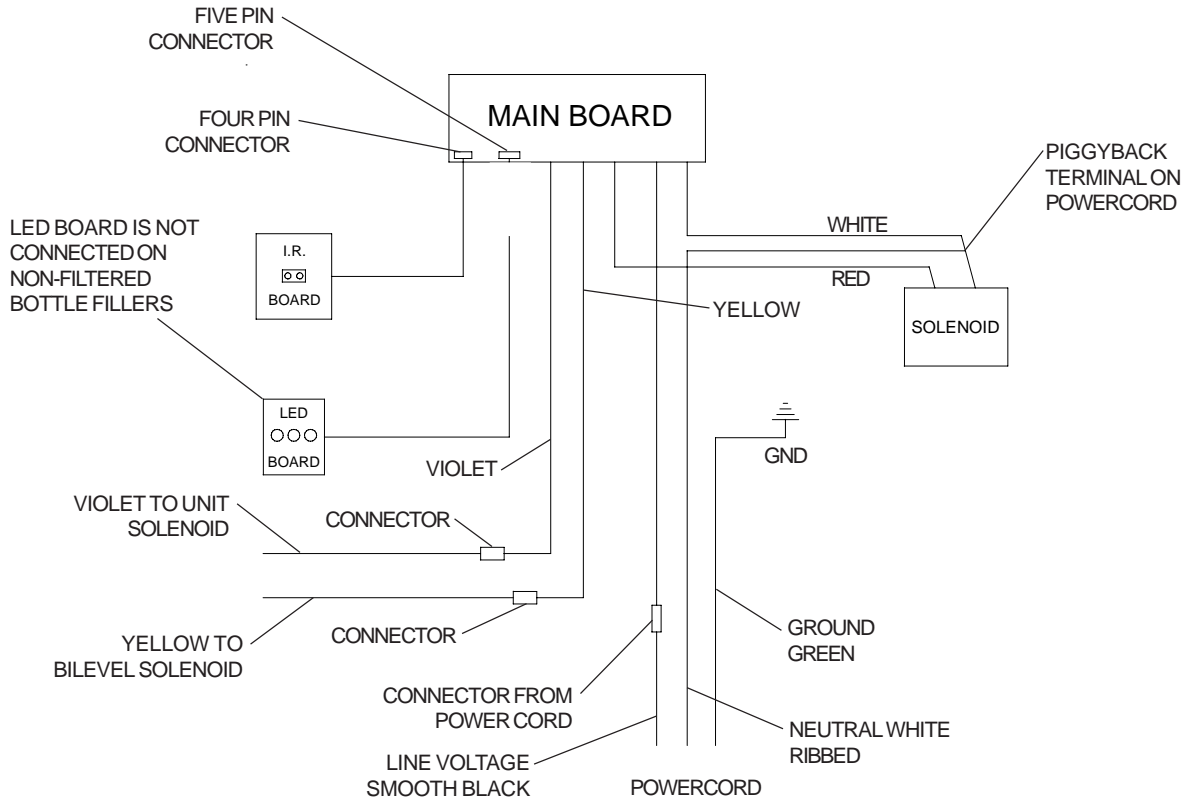
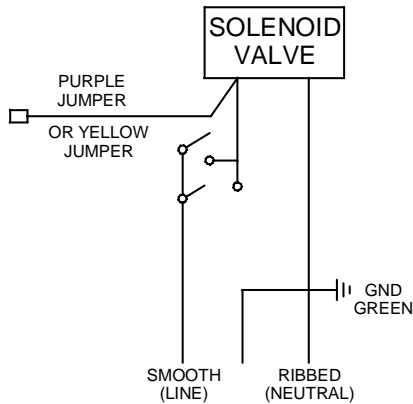


Fig. 6

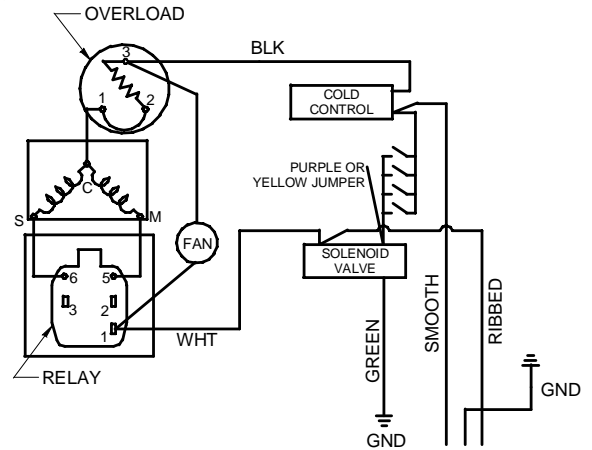


WIRING DIAGRAM - BOTTLE FILLER 115V

NOTE: UNITS PRODUCED 2008 AND BEFORE WILL NEED ADAPTERS TO SWITCH LINE AND NEUTRAL WIRES.



WIRING DIAGRAM - NON REFRIGERATED SIDE



WIRING DIAGRAM - REFRIGERATED SIDE

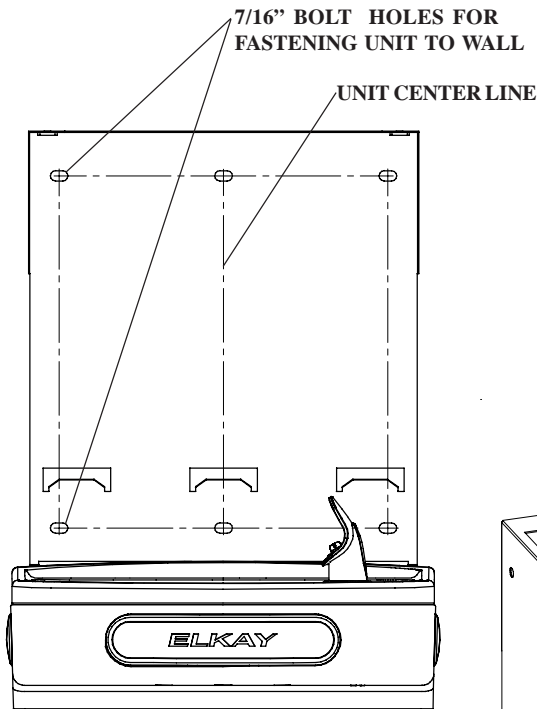


Fig. 7

WALL MOUNTING PLATE

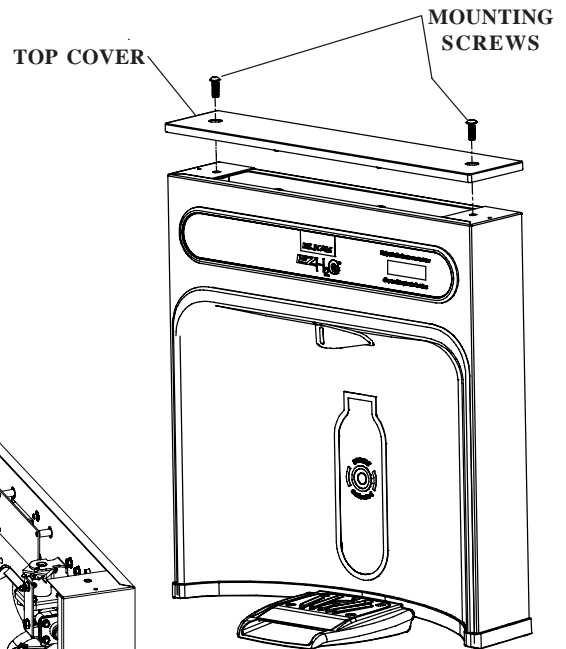


Fig. 8

BOTTLE FILLING UNIT

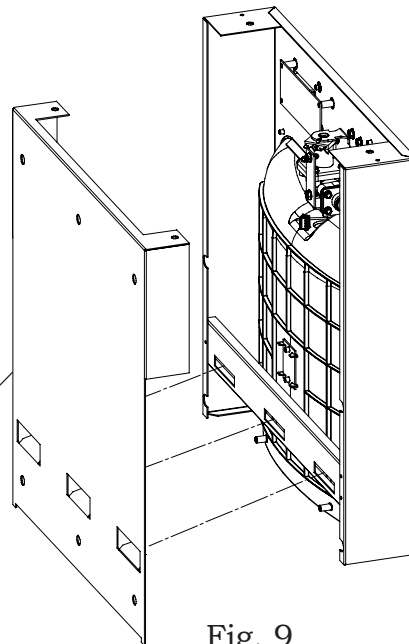


Fig. 9

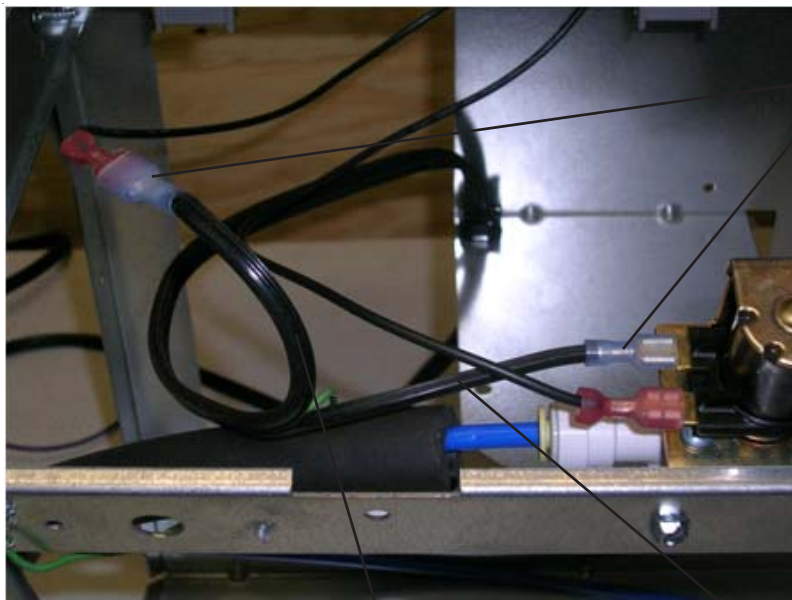
BOTTLE FILLER INSTALLATION

- 1) Remove two (2) mounting screws with 5/32" allen wrench holding top cover to Bottle Filler (See FIG. 8). Remove top cover. Note do not discard mounting screws, they will be needed to reinstall top cover..
- 2) Remove wall mounting plate from Bottle Filler. Place Wall plate against wall on top of EZ basin. Center the wall plate side to side with the EZ basin. Mark the six (6) mounting holes with a pencil (See FIG. 7).
- 3) Remove wall mounting plate from wall. **NOTE:** Mounting plate **MUST** be supported securely. Add fixture support carrier if wall will not provide adequate support.
- 4) Install wall mounting plate to wall using six (6) 7/16" obround mounting holes (mounting bolts not included) (See FIG. 9). Use appropriate fasteners for your wall type.
- 5) Place Drain Mat into position on the bottom of the Bottle Filler Unit.
- 6) **For Single Model installations:** Attach the purple wire from cooler to the purple wire on the back of the unit, (Note yellow wire is not used).
- 6a) **For Two-Level model installations:** Attach the purple and yellow wires from coolers to the purple and yellow wires on the back of the unit, purple to purple, yellow to yellow.
- 7) Remove 3/8" to 1/4" reducing union from end of waterline, (do not throw away it will be needed later). Lay Bottle Filler on water cooler basin and cut insulation from tube even with bottom of unit, remove this insulation from 3/8" tube, but do not discard. Fish the power cord, and waterline through the hole on top of water cooler created from the "Water Cooler Preparation" section. **NOTE:** To prevent scratching the basin place a towel or soft cloth over the entire basin when working above it.
- 8) With the power cord and waterline through hole on top of water cooler place Bottle Filler on the three (3) angled tabs protruding from the wall mounting plate, installed on wall (See Fig. 9). Make sure rubber Drain Mat is installed properly on bottom of Bottle filler (See Cover Illustration).
- 9) Once Bottle Filler is installed on wall plate tabs, drain mat, water line, wire(s) and power cord are installed properly, push top of Bottle Filler toward wall and line up top cover two (2) holes.
- 10) Reinstall Top Cover on Bottle Filler (See FIG. 8) with two mounting screws from step 1 above. Caution do not over tighten screws.
- 11) Install remaining tube insulation on to water line from bottle filler, connect Bottle Filler waterline inside to the water cooler by connecting the 3/8" water line with the 3/8" to 1/4" union and short piece of poly tube to the tee. (See Fig. 4, 4A or 4B).
- 12) Turn water supply on and inspect for leaks. Fix all leaks before continuing.
- 13) Once unit has been inspected for leaks and any leaks found corrected plug Bottle Filler and LZ unit into wall. Be sure to reinstall fuse to the circuit or switch the circuit breaker back to the "ON" position.
- 14) Once power is applied to Bottle Filler, the LCD Bottle Counter should illuminate.
- 15) Verify proper dispensing by placing cup, hand, or any opaque object in front of sensor area and verify water dispenses. Note: the first initial dispenses might have air in line which may cause a sputter. This will be eliminated once all air is purged from the line. **NOTE:** If your Bottle Filler Counter continuously advances, see page 9 for wiring changes to the non-refrigerated unit to correct the problem. The included adapter wires may only be needed on Two-Level Units manufactured before JANUARY 2009.
- 16) Once unit tests out, install Lower Panel back on EZ water cooler(s). Units are now ready for use.

**WIRING MODIFICATION FOR NON-REFRIGERATED UNIT IN A TWO-LEVEL COOLER
IF BOTTLE FILLER COUNTER CONTINUOUSLY ADVANCES**

1) DISCONNECT POWER TO ALL UNITS BEFORE PROCEEDING!

- 2) Disconnect ribbed wire (powercord) from the switch wire (from pushbar), add the female to female adapter to wire.
- 3) Remove the smooth larger black wire (powercord) from the solenoid valve. Connect ribbed wire with female adapter from step 2 to where the smooth black wire was connected.
- 4) Add the male to male adapter to the smooth wire removed in step 3.
- 5) Connect the smooth black wire with male adapter to the switch wire (from pushbar) removed in step 2.
- 6) Reconnect power to all units. Verify bottle filler counter advances only when water is flowing.
- 7) Once unit tests out, install lower panels back on EZ water coolers. Units are ready for use.



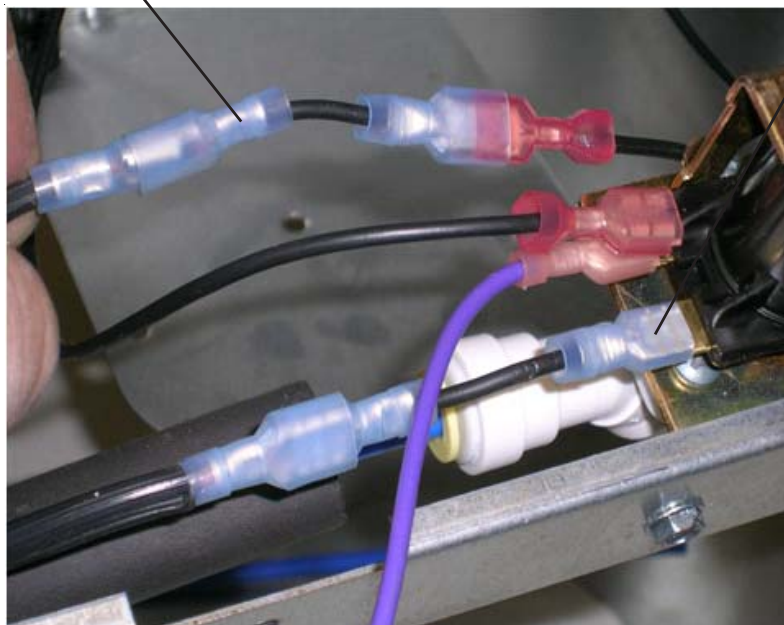
REVERSE THESE TWO WIRES ON THE NON-REFRIGERATED UNIT OF TWO LEVEL MODELS ONLY USING THE PROVIDED ADAPTERS.

POWERCORD BLACK RIBBED WIRE

POWERCORD BLACK SMOOTH WIRE

MALE TO MALE ADAPTER

FEMALE TO FEMALE ADAPTER



UNIT WITH WIRE ADAPTERS ADDED AND WIRED CORRECTLY

SETTING THE CONTROL BOARD - SETTING RANGE OF THE IR SENSOR

- 1) In order to access the programming button, you must remove the top cover of the bottle filler. Remove the two (2) screws with a 5/32" allen wrench holding top cover to Bottle Filler. Remove top cover. Do not discard mounting screws, they will be needed to reinstall the top cover
- 2) With your finger, reach inside the opening and depress the program button located behind the LCD display outside of the electronics cover for approximately 2 seconds until the display changes then release. The display will change and scroll through three messages:
 - "RST FLTR"** – Reset Filter Status LED
 - "RST BCNT"** – Reset Bottle Count
 - "RNG SET"** – Range Set for IR Sensor

If the program button is not pushed again the display will scroll through the three messages above for three cycles and then default back to bottle count and be back in run mode.

- 1) To set the RANGE of IR Sensor: when display shows "RNG SET" push program button once the display will show current value (can be 1 – 10) i.e. **"RNG = 3"**.
- 2) Once display shows current value push the program button to scroll through value of 1 – 10. Select the desired range setting.
- 3) Once range is selected allow approximately 4 seconds to pass and then the display will go back to bottle counter and be in run mode.
- 4) Test bottle filler by placing bottle or hand in front of sensor to make sure water is dispensed.

SETTING THE CONTROL BOARD - RESETTING BOTTLE COUNT

- 1) In order to access the programming button, you must remove the top cover of the bottle filler. Remove the two (2) screws with a 5/32 allen wrench holding top cover to Bottle Filler. Remove top cover. Do not discard mounting screws, they will be needed to reinstall the top cover
- 2) With your finger, reach inside the opening and depress the program button located behind the LCD display outside of the electronics cover for approximately 2 seconds until the display changes then release. The display will change and scroll through three messages:
 - "RST FLTR"** – Reset Filter Status LED
 - "RST BCNT"** – Reset Bottle Count
 - "RNG SET"** – Range Set for IR Sensor

If the program button is not pushed again the display will scroll through the three messages above for three cycles and then default back run mode which display bottle count.

- 3) To reset the BOTTLE COUNTER: when display shows "RST BCNT" push program button once the display will show current value i.e. "BC0033183".
- 4) Once display shows current value push the program button once more to reset back to 0. The display will show BTLCT = 0 for approximately 2 seconds and then return to run mode showing 00000000 bottles.
- 5) To test bottle counter, you can place bottle or hand in front of sensor for approx 5 seconds to see bottle counter count 00000001. (This is based on filling a 16 oz bottle)

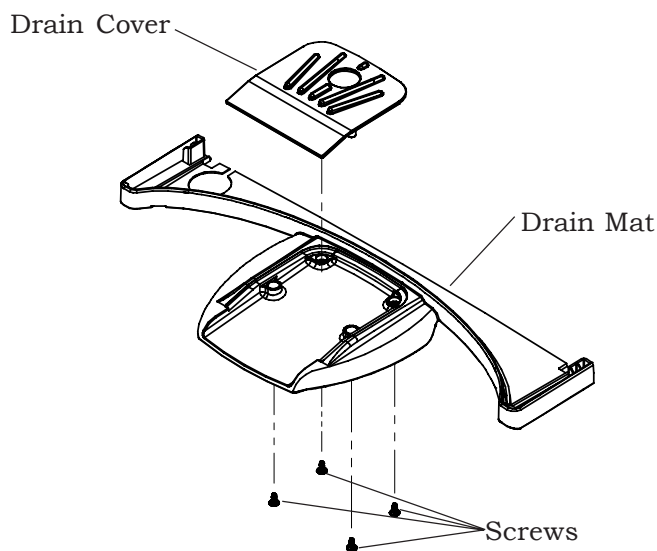
**DRAIN MAT EXPLODED VIEW**

Fig. 10

DRAIN MAT ASSEMBLY AND CARE

- 1) Place Drain Cover on mat and install the four screws as shown in Fig.15.
- 2) It is recommended that the cover be removed and the drain cover be cleaned weekly. To dis-assemble or re-assemble the drain cover the mat can be picked up from the front to access the screws beneath.

REPLACEMENT PART KITS

PART NO.	DESCRIPTION
98543C	Kit - Electrical Package 115V
98544C	Kit - IR Sensor 115V
98545C	Kit - Solenoid Valve Replacement 115
98546C	Kit - Aerator Replacement
98547C	Kit - Top Cover Replacement
98675C	Kit - Drain Mat & Cover Replacement
98549C	Kit - Hardware & Waterway Parts

REPAIR SERVICE INFORMATION TOLL FREE NUMBER 1.800.260.6640
 NÚMERO GRATIS DE SERVICIO 1.800.260.6640
 INFORMATIONS POUR LE SERVICE PAR NUMERO SANS FRAIS 1.800.260.6640

FOR PARTS, CONTACT YOUR LOCAL DISTRIBUTOR OR CALL 1.800.323.0620
 PARA PIEZAS, CONTACTE A SU DISTRIBUIDOR LOCAL O LLAME AL 1.800.323.0620
 POUR OBTENIR DES PIÈCES, CONTACTEZ VOTRE DISTRIBUTEUR LOCAL OU COMPOSEZ LE 1.800.323.0620

PRINTED IN U.S.A.
 IMPRESO EN LOS E.E.U.U.
 IMPRIMÉ AUX É.-U.