

INSTRUCTION MANUAL

PF6000 . PF7000



PARTS LIST - PF6000		
1	10210	Cartridge Cold, Lead Free
2	10560	Cache Aerator Junior 1.5GPM
3	10686 *	Escutcheon Flange
4	10694	Injector Shank, 1/2"NPT
5	3-042 *	Handle, PF Standard Lever Swan
6	3-044 *	Handle, PF Decorative Swan
7	92060	Set Screw
8	90113	'O' Ring -113
9	90128	'O' Ring -128

*NOTE: Specify color finish when ordering replacement parts

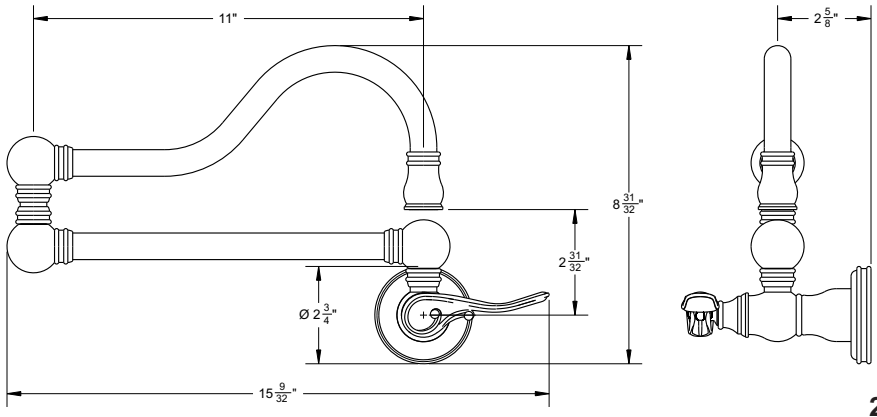
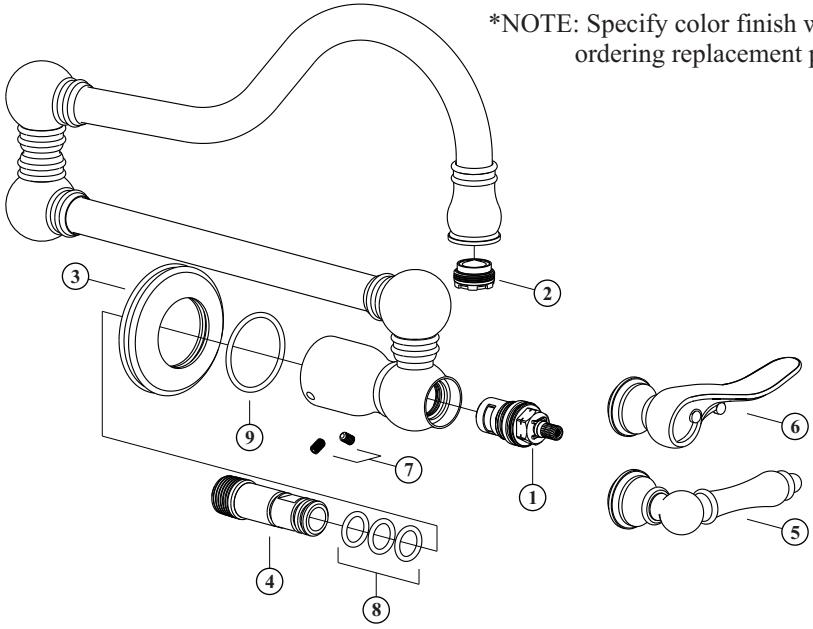

PARTS LIST - PF7000

1	10210	Cartridge Cold, Lead Free
2	10560	Cache Aerator Junior 1.5GPM
3	10686 *	Escutcheon Flange
4	10694	Injector Shank, 1/2"NPT
5	3-043 *	Handle, PF Standard Lever Lalingua
6	3-045 *	Handle, PF Decorative Lalingua
7	92060	Set Screw
8	90113	'O' Ring -113
9	90128	'O' Ring -128

*NOTE: Specify color finish when ordering replacement parts

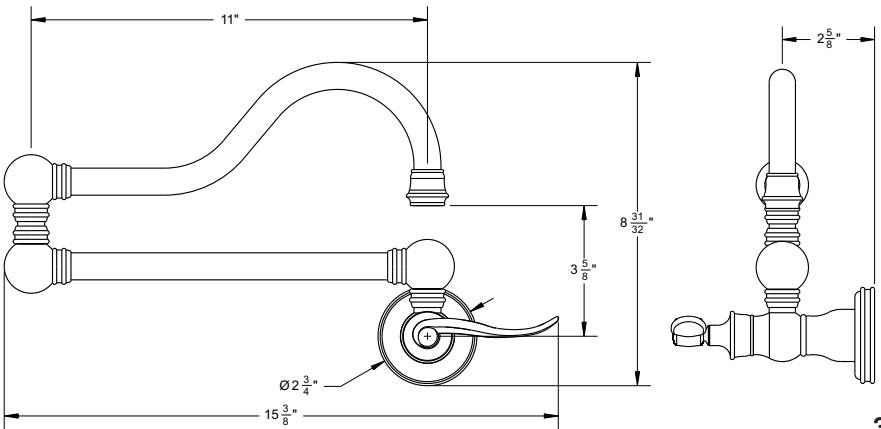
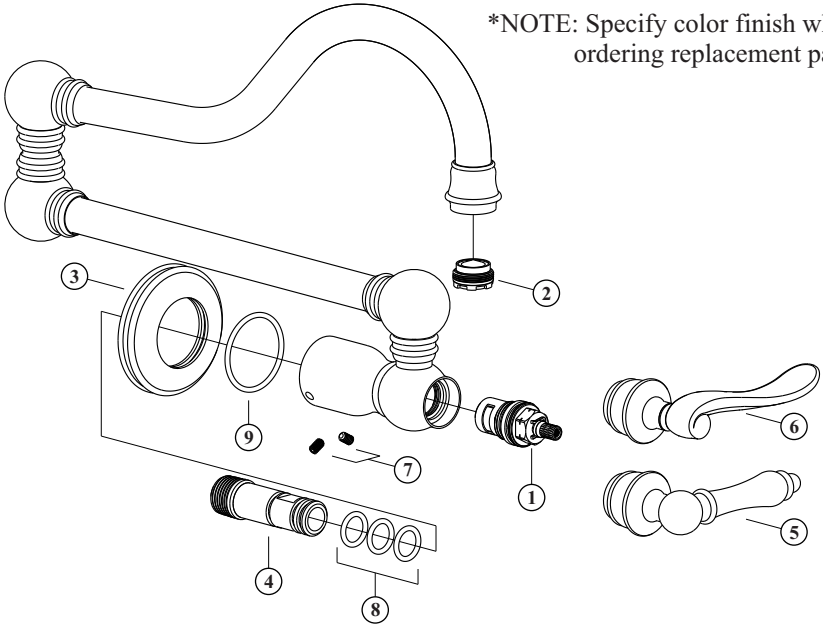

TECHNICAL DATA

Standard water flow 1.5 gpm - 45 PSI

Maximum water flow 2.2 gpm - 60 PSI

Recommended pressure range 25-100 PSI - Over 100 PSI PRV required

Complies with Proposition 65, NSF 61, UPC and C-UPC requirements

FAUCET INSTALLATION

1. Remove all contents from the package and check for completeness.

NOTE:

Call us immediately if you see inconsistencies.

(1-800-626-5771)

or visit

www.franke.com

info.fks@franke.com

TABLE OF CONTENT

1	Faucet
2	Escutcheon & 'O'Ring
3	Injector Mount

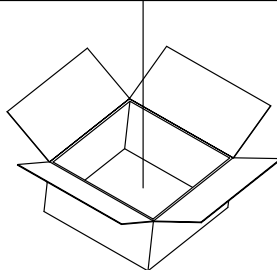
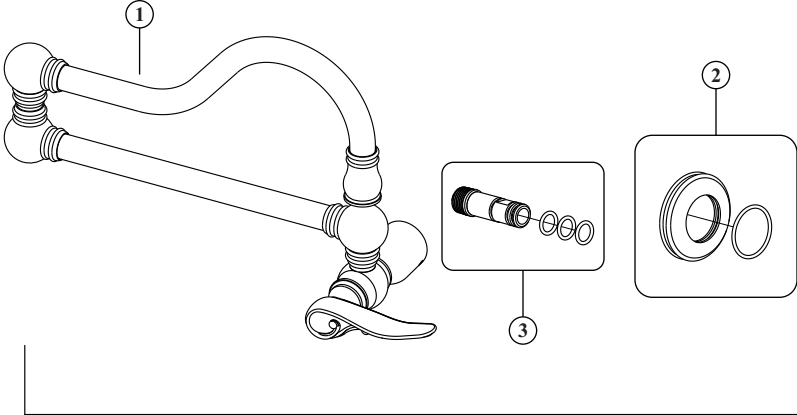

2. Flush pipe work to ensure it is free from debris.
3. Remove faucet and hardware from its protective packaging. Unscrew injector mount from back side of faucet.
4. Place the escutcheons and large 'O'rings over the back end of the faucet and place the faucet into the desired position.

ATTENTION: The rubber 'O' ring should be sitting between the wall the faucet escutcheon. **DO NOT** use putty or other sealant at this location.

NOTE:

Solid surface installation: The sub-countertop mounting surface needs to be flat and free of debris; otherwise the faucet will not sit properly.

Tile installation: Avoid installations near or on top of grout lines. The escutcheon will not sit secure when sitting on such.

5. Assure that the handle and spout are properly aligned in correct positions; spout should swivel face forward toward range and handle should point outward parallel with horizon. Handle should 1/4" turn downward toward counter top (clockwise).

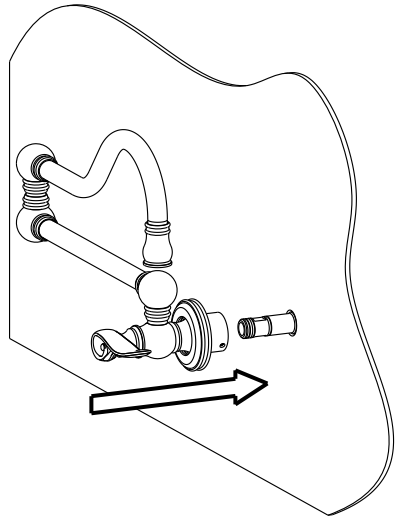
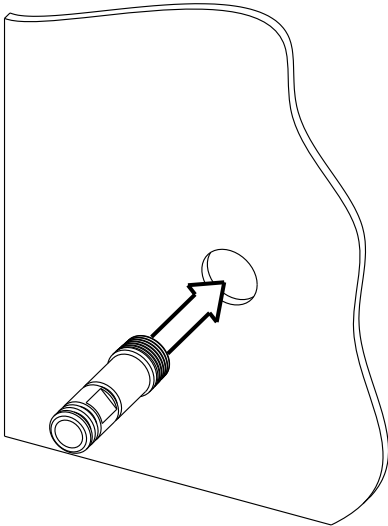

6. Tighten injector shank into pre-plumbed 1/2" NPT female fitting.
7. Push faucet up to finished wall onto injector.

8. Ensure faucet is horizontally level before set screws are fastened.

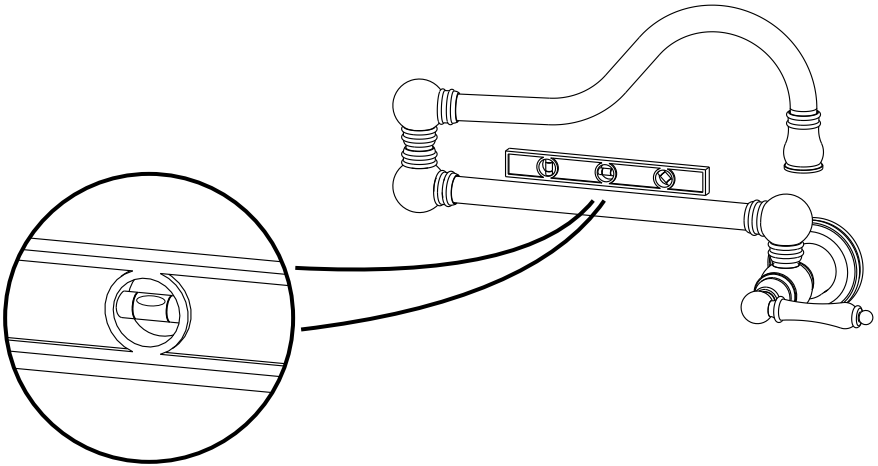

9. Tighten the two set screws onto the injector until fastened. Then, push back escutcheon up to finished wall.

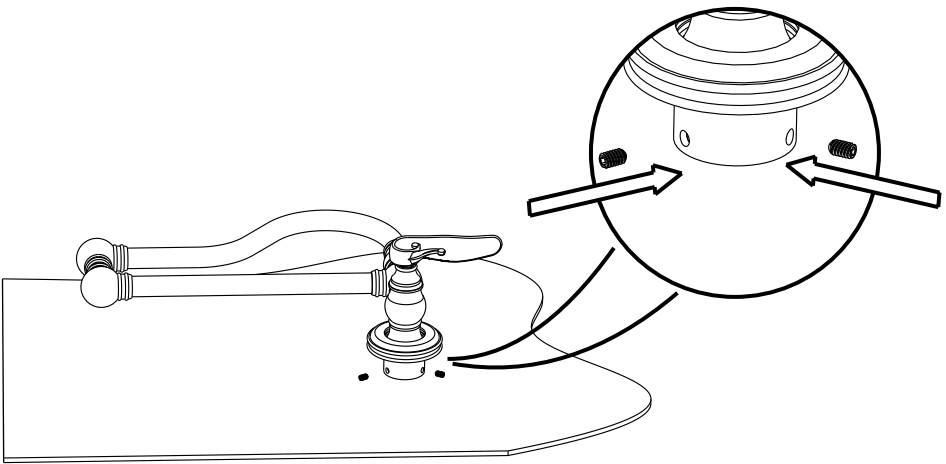

10. Turn water supply back on to faucet.

11. Open faucet handle by turning handle clockwise. Let the faucet run over a pot for 15 to 30 seconds.

12. Turn faucet off.

13. Check / test for leaks.

STANDARD MAINTENANCE AND TROUBLE SHOOTING

REPLACING THE CARTRIDGE

1. Shut off the water supply to the faucet.
2. Open the faucet briefly to relieve any pressure inside the faucet.
3. Move the faucet handle to the “OFF” position.
4. Remove handle assembly to access cartridge.
5. Remove cartridge from valve body seat by using a 17mm socket wrench.
5. Install the new cartridge into valve body; ensure to tighten cartridge to 14 ft./lbs. (18.9 Nm).
6. Re-assemble faucet in reverse order.
7. Test for leakage.

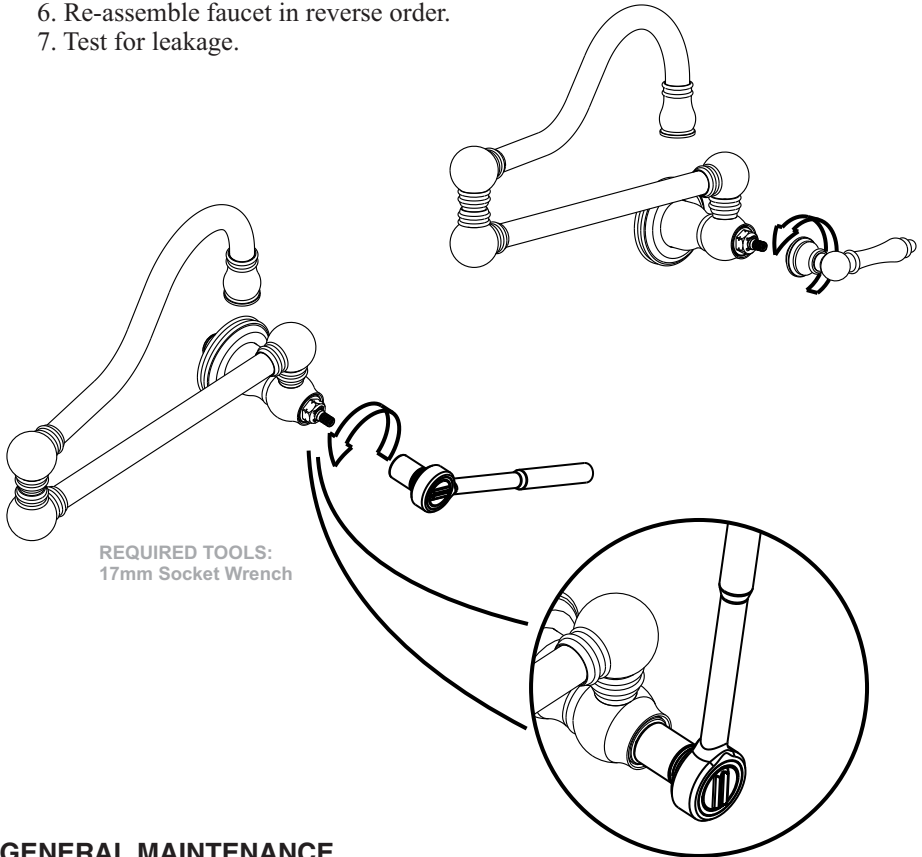

REQUIRED TOOLS:
17mm Socket Wrench

GENERAL MAINTENANCE

Clean aerator periodically.

Do not use harsh detergents, solvents, chemical agents, metallic sponges, etc. that could harm the surface and damage the finish.

Clean only with a soft sponge and soapy water.

LIMITED LIFETIME WARRANTY

Franke Consumer Products, Inc., Kitchen Systems Division extends the following warranty to the original purchaser of its faucets effective January 1, 2003.

All faucets installed in a private residence will carry a limited lifetime warranty on all mechanical parts to be free of manufacturing defects in material and workmanship under normal usage. All chrome finishes carry a limited lifetime warranty; all other finishes are warranted for five (5) years from the original date of purchase.

This warranty applies only to the original owner, providing the product has been installed in accordance with our installation instructions, used as recommended and in a normal residential application. **In the event of a warranty claim, the owner will be required to provide proof of purchase - save sales receipt.** This warranty covers all components which make the product operational. Franke, at its option, may repair or replace the product or components necessary to restore the product to good working condition. Franke reserves the right to inspect the installation *prior* to the actual replacement of the product or component part.

This warranty does not cover misuse or abuse, accidental damages, scuffs or scratches, improper installation, abnormal usage, negligence or damage caused by improper maintenance or cleaning. Normal wear of parts is excluded from the warranty. Damage caused by impurities or acts beyond our control are not covered. Any product or part which has been repaired or altered in any manner outside of Franke's factory, unless previously authorized in writing by Franke, will void warranty. **Any replacement excludes transportation and any labor re-installation costs.** This warranty does not allow recovery of incidental or consequential damages such as loss of use, delay, property damage or other consequential damage, and Franke accepts no liability for such damages.

The Franke warranty is limited to the above conditions and to the warranty period specified herein and is exclusive. Franke **DISCLAIMS** all other warranties, expressed or implied, including **IMPLIED WARRANTIES OF MERCHANTABILITY AND/OR FITNESS FOR AS PARTICULAR PURPOSE**. This warranty gives you specific legal rights that may vary from state to state.

Further information

For any further information about our products, about the installation of them or about the guarantee, please dial the number of the customer service:

Phone number +1-215-822-6590
Or: 1-800-626-5771
Fax number + 1-215-822-5873

Franke Consumer Products Inc. - Kitchen Systems Division
3050 Campus Drive, Suite Hatfield, PA 19440