

# Installation Instructions / Warranty

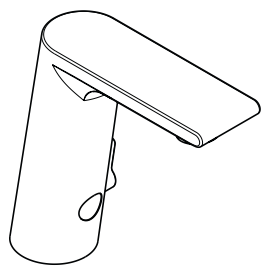

**Metris**  
31102XX1

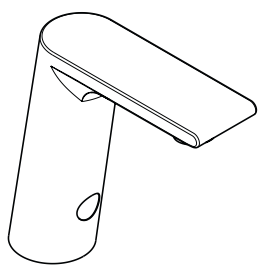

**Metris**  
31103XX1

**hansgrohe**

# Metris Electronic Lavatory Faucet with Temperature Control 31102XX1

## Metris Electronic Lavatory Faucet 31103XX1

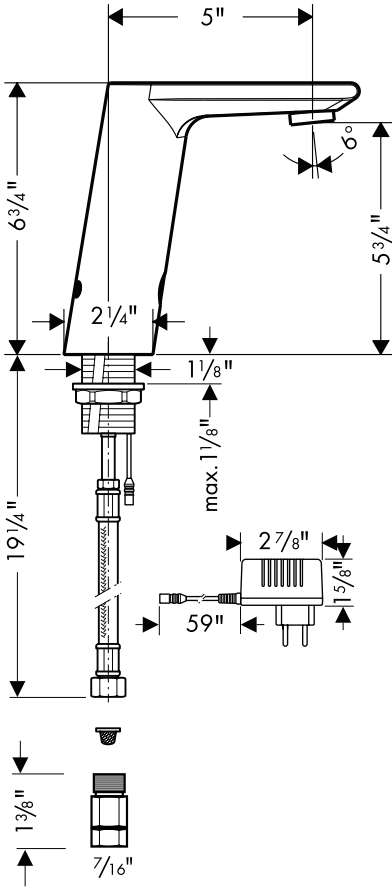

### Technical Data

Max. water pressure	116 psi
Recommended pressure	14.5 - 72 psi
Max. hot water temp.	158°F*
Recommended hot water temp.	120°F - 140°F*
Flow rate	1.5 gpm max.
Automatic shutoff	after 35 seconds**
Hole size in mounting surface	1 1/4"
Max. mounting surface thickness	1 1/8"

\*Please know and follow all applicable local plumbing codes when setting the temperature on the water heater.  
 \*\*This is the maximum amount of time that the faucet will run while the hand is within range of the sensor.

### Installation Considerations

- This faucet requires a 110 V electrical outlet which must be installed by a professional electrician in compliance with all applicable local codes.
- This faucet includes a transformer that must be used. **Do not attempt to hardwire this faucet.**
- This faucet cannot be used with a continuous flow water heater.
- For best results, Hansgrohe recommends that this unit be installed by a licensed, professional plumber.

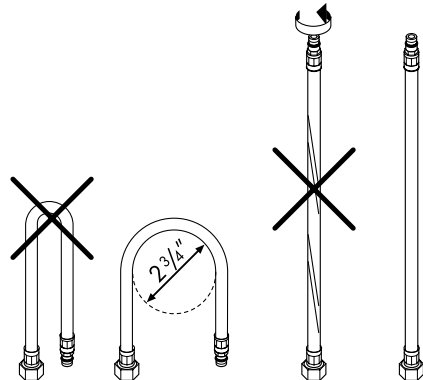

**Caution:** Do not twist or kink the supply hoses!

## Installation

Flush the hot and cold supplies thoroughly before installing this faucet.

Place the faucet in the hole on the mounting surface (1).

Tighten the mounting nut (2).

Install the adapters and filters on the stops (3).

Install the supply lines (4). Be careful not to twist the supply lines, or they may become loose from the faucet, causing a leak.

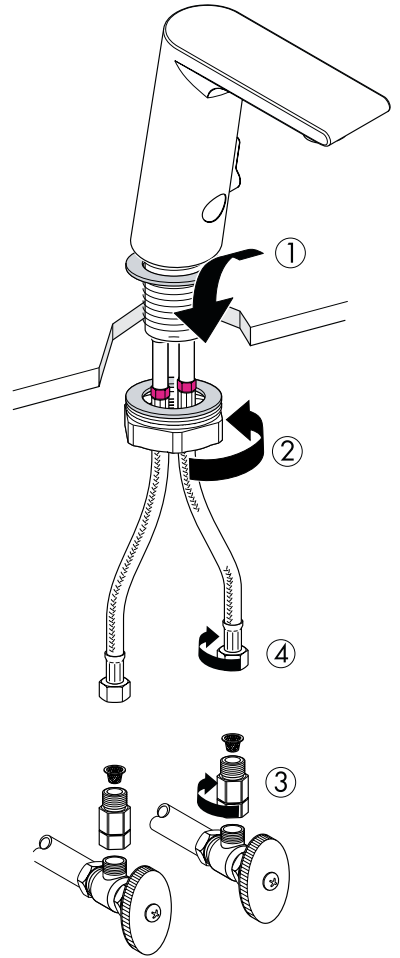

Connect the transformer to the faucet. Plug the transformer into the outlet.

Use a cable tie to bundle the excess cable.

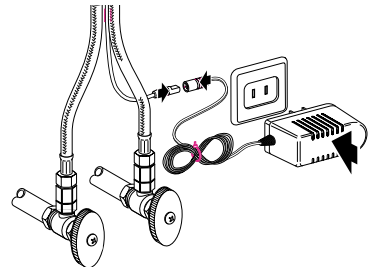

Turn the water on to the faucet (1).

Peel the protective film from the sensor (2).

Wait 15 seconds, then place a hand in front of the sensor (3). The water should turn on automatically.

**Model 31102 only:** Pivot the temperature control lever forward to make the water cooler (4).

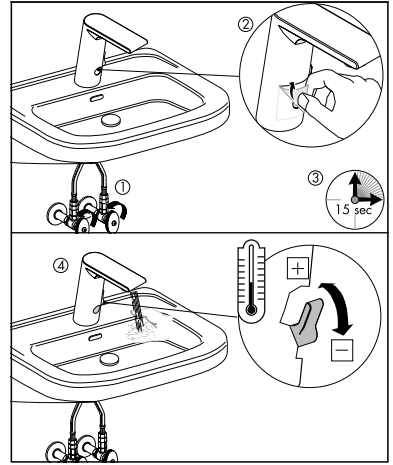

### **Model 31103 only: Set the temperature**

Turn the water off at the stops.

Remove the set screw on the back of the faucet.

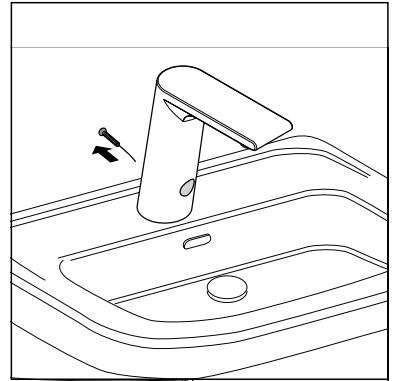

Pull the faucet housing off (1).

Use a screwdriver to set the water temperature (2). Turn the screw to the rear to make the water warmer, to the front to make it cooler.

Replace the faucet housing. Tighten the set screw.

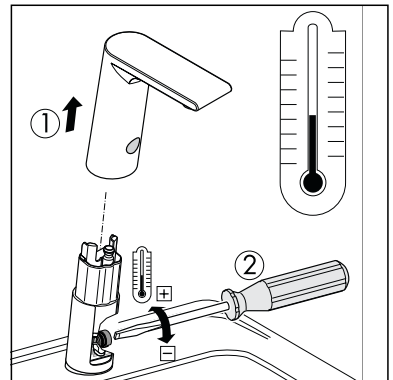

## Cleaning:

Block the sensor for 5 seconds (1).

This will turn the water off for approximately 90 seconds, so that the sink may be cleaned (2).

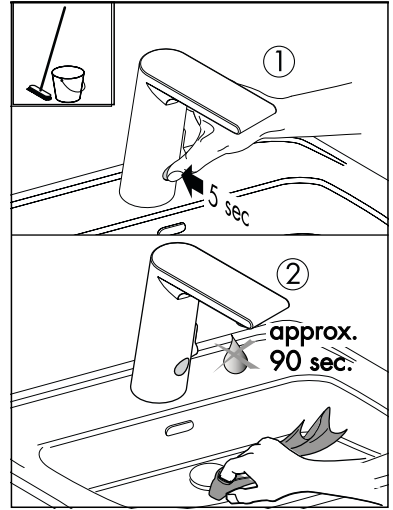

## Faucet Maintenance

**Reset the faucet:** Remove the set screw with a 2.5 mm Allen wrench.

Block the sensor for 2 seconds.

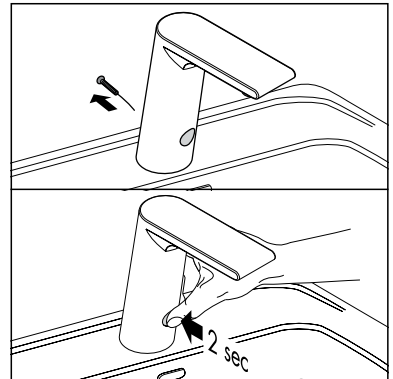

Wait 10 seconds (1), then replace the set screw (2).

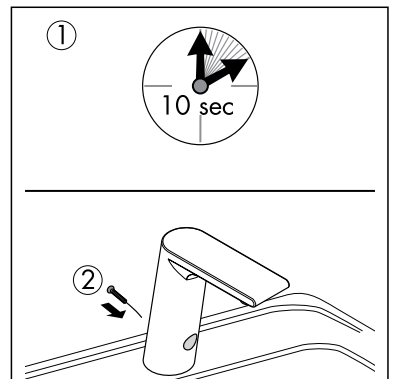

Wait 15 seconds (3). Place a hand in front of the sensor (4). The water should turn on.

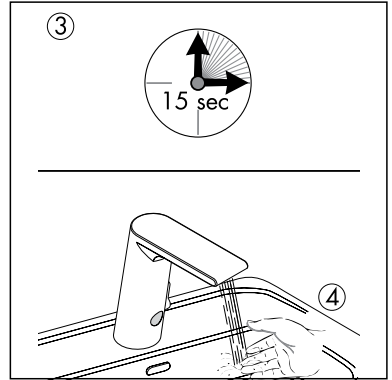

### Clean the filters and aerator

If the flow of water is reduced, the aerator and/or the filters must be cleaned.

**To clean the aerator:** Block the sensor for 5 seconds to temporarily shut off the water (1).

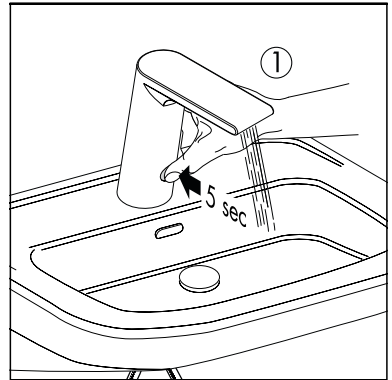

Unscrew and remove the vandal resistant aerator using the enclosed key (2). Flush any debris from the aerator at another faucet.

Replace the aerator.

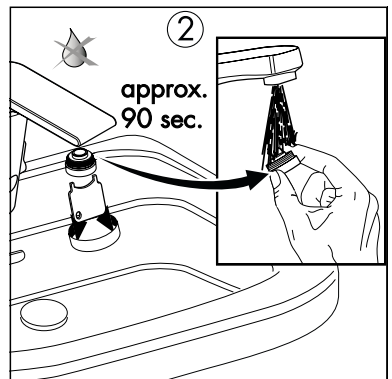

**To clean the filters:** Turn the water off at the stops.

Disconnect the supply hoses from the adapters. Remove and clean the filters.

**Note:** Remove and inspect the check valves yearly.

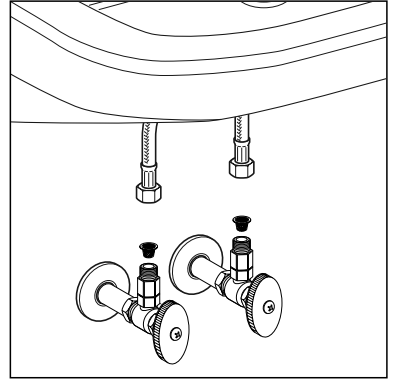

# Replacement Parts

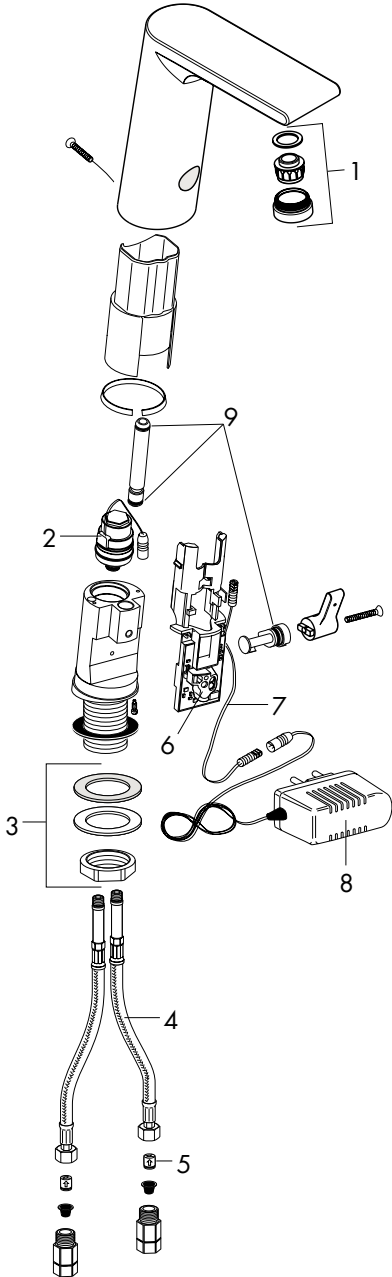

1	aerator	95383000
2	solenoid valve	98854000
3	fixation set	97812000
4	connection hose	98809000
5	check valve	96456000
6	electronics	96905000
7	AC adapter	97690000
8	transformer	97689001
9	8 x 2 o-ring	98112000

**Important note:** the check valves should be removed and inspected yearly.



# Cleaning Recommendation for Hansgrohe Products

Modern lavatory faucets, kitchen faucets, and showers consist of very different materials to comply with the needs of the market with regard to design and functionality. To avoid damage and returns, it is necessary to consider certain criteria when cleaning.

## Cleaning Materials for Faucets and Showers

Acids are a necessary ingredient of cleaning materials for removing lime, however please pay attention to the following points when cleaning faucets and showers:

- Only use cleaning materials which are explicitly intended for this type of application.
- Never use cleaning materials which contain hydrochloric, formic, phosphoric, or acetic acid, as they cause considerable damage.
- Never mix one cleaning material with another.
- Never use cleaning materials or appliances with an abrasive effect, such as unsuitable cleaning powders, sponge pads, or micro fiber cloths.

## Cleaning Instructions for Faucets and Showers

Please follow the cleaning material manufacturer's instructions. In addition, pay attention to the following points:

- Clean the faucets and showers as and when required
- Use the amount of cleaning product and the amount of time recommended by the manufacturer. Do not leave the cleaner on the fixture longer than necessary.
- Regular cleaning can prevent calcification.
- When using spray cleaners, spray first onto a soft cloth or sponge. Never spray directly onto the faucet as droplets can enter openings and gaps and cause damage.
- After cleaning, rinse thoroughly with clean water to remove any cleaner residue.

## Important

Residues of liquid soaps, shampoos, and shower foams can also cause damage, so rinse with clean water after using.

**Please note:** if the surface is already damaged, the effect of cleaning materials will cause further damage.

**Components with damaged surfaces must be replaced or injury could result.  
Damage caused by improper treatment is not covered under the warranty.**

# Limited Lifetime Consumer Warranty

This product has been manufactured and tested to the highest quality standards by Hansgrohe, Inc. ("Hansgrohe"). This warranty is limited to Hansgrohe products which are purchased by a consumer in the United States after March 1, 1996, and installed in either the United States or Canada.

## WHO IS COVERED BY THE WARRANTY

This warranty extends to the original consumer purchaser only. This warranty is non-transferable.

## WHAT IS COVERED BY THE WARRANTY

This warranty covers only your Hansgrohe manufactured product. Hansgrohe warrants this product against defects in material or workmanship as follows: Hansgrohe will repair at no charge for parts only or, at its option, replace any product or part of the product that proves defective because of improper workmanship and/or material, under normal installation, use, service and maintenance. If Hansgrohe is unable to provide a replacement and repair is not practical or cannot be timely made, Hansgrohe may elect to refund the purchase price in exchange for the return of the product.

## LENGTH OF WARRANTY

Replacement or repaired parts of products will be covered for the term of this warranty as stated in the following two sentences. If you are a consumer who purchased the product for use primarily for personal, family, or household purposes, this warranty extends for as long as you own the product and the home in which the product is originally installed. If you purchased the product for use primarily for any other purpose, including, without limitation, a commercial purpose, this warranty extends only (i) for 1 year, with respect to Hansgrohe and Commercial products, and (ii) for 5 years, with respect to AXOR products.

## THIS WARRANTY DOES NOT COVER, AND HANSGROHE WILL NOT PAY FOR:

- A. Conditions, malfunctions or damage not resulting from defects in material or workmanship.
- B. Conditions, malfunctions or damage resulting from (1) normal wear and tear, improper installation, improper maintenance, misuse, abuse, negligence, accident or alteration, or (2) the use of abrasive or caustic cleaning agents or "no-rinse" cleaning products, or the use of the product in any manner contrary to the product instructions. (3) Conditions in the home such as excessive water pressure or corrosion.
- C. Labor or other expenses for the disconnection, deinstallation, or return of the product for warranty service, or for installation or reinstallation of the product (including but not limited to proper packaging and shipping costs), or for installation or reinstallation of the product.
- D. Accessories, connected materials and products, or related products not manufactured by Hansgrohe.

## TO OBTAIN WARRANTY PARTS OR INFORMATION

Contact your Hansgrohe retailer, or contact Technical Service at:

Hansgrohe Inc.  
1492 Bluegrass Lakes Parkway  
Alpharetta GA 30004  
Toll-free (800) 334-0455.

In requesting warranty service, you will need to provide

- 1. The sales receipt or other evidence of the date and place of purchase.
- 2. A description of the problem.
- 3. Delivery of the product or the defective part, postage prepaid and carefully packed and insured, to Hansgrohe Inc. 1492 Bluegrass Lakes Parkway, Alpharetta, Georgia 30004, Attention: Technical Service, if required by Hansgrohe.

When warranty service is completed, any repaired or replacement product or part will be returned to you postage prepaid.

## EXCLUSIONS AND LIMITATIONS

REPAIR OR REPLACEMENT (OR, IN LIMITED CIRCUMSTANCES, REFUND OF THE PURCHASE PRICE) AS PROVIDED UNDER THIS WARRANTY IS THE EXCLUSIVE REMEDY OF THE PURCHASER. HANSGROHE NEITHER ASSUMES NOR AUTHORIZES ANY PERSON TO CREATE FOR IT ANY OBLIGATION OR LIABILITY IN CONNECTION WITH THIS PRODUCT.

HANSGROHE SHALL NOT BE LIABLE TO PURCHASER OR ANY PERSON FOR ANY INCIDENTAL, SPECIAL, OR CONSEQUENTIAL DAMAGES, ARISING OUT OF BREACH OF THIS WARRANTY OR ANY IMPLIED WARRANTY (INCLUDING MERCHANTABILITY).

Some States do not allow the exclusion or limitation of incidental or consequential damages, so the above limitation or exclusion may not apply to you. This warranty gives you specific legal rights, and you may have other rights which vary from State to State. You may be required by law to

give us a reasonable opportunity to correct or cure any failure to comply before you can bring any action in court against us under the Magnuson-Moss Warranty Act.

#### PRODUCT INSTRUCTIONS AND QUESTIONS

Upon purchase or prior to installation, please carefully inspect your Hansgrohe product for any damage or visible defect. Prior to installing, always carefully study the enclosed instructions on the proper installation and the care and maintenance of the product. If you have questions at any time about the use, installation, or performance of your Hansgrohe product, or this warranty, please call or write to us or call us toll-free at 800 334 0455.

**hansgrohe**

Hansgrohe, Inc. • 1490 Bluegrass Lakes Parkway • Alpharetta, GA 30004  
Tel. 770 360-9880 • Fax 770 360 9887

**[www.hansgrohe-USA.com](http://www.hansgrohe-USA.com)**