

Product Features

- Brass valve body
- Anti-scald – maintains desired temperature + / - 3°F
- ½" IPS or ½" CWT inlets and outlets
- Includes plaster shield and test plug
- Cartridge is reversible for back-to-back installations
- Flow rate 4.25 gpm @ 45 psi
- Can be used with diverter tub spout for tub/shower installation
- Cartridge incorporates rotational limit stop, which may be reset to comply with local plumbing codes
- Includes service (isolation) stops

Code Compliance

This unit meets or exceeds the following (when installed with trim kit):

- ASME A112.18.1
- CSA B125.1
- Listed by IAPMO

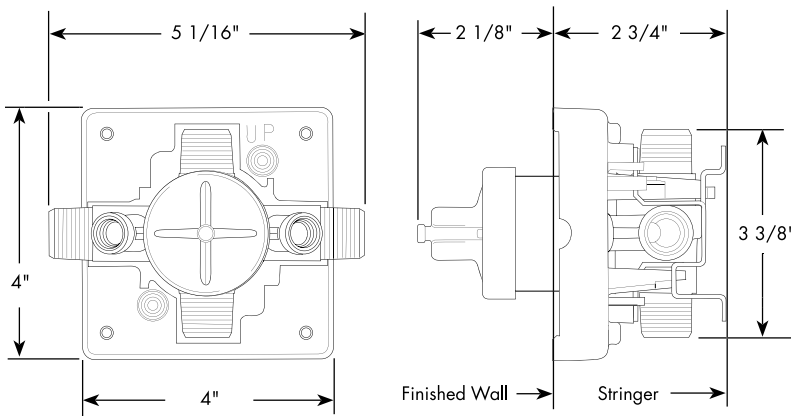

Required Accessories

Requires trim kit – many styles available

The measurements shown are for reference only.

Products and specifications shown are subject to change without notice.

Specification sheet revised 2/2010