

Type _____

-09 -20

P7127

Catalog No.	Finish		Lamping	Dimensions (Inches)			
	Brushed Nickel	Antique Bronze		A	B	C	D
P7127	-09	-20	2 (c) 60w	12-3/4	13-5/8	5-7/8	9-3/4

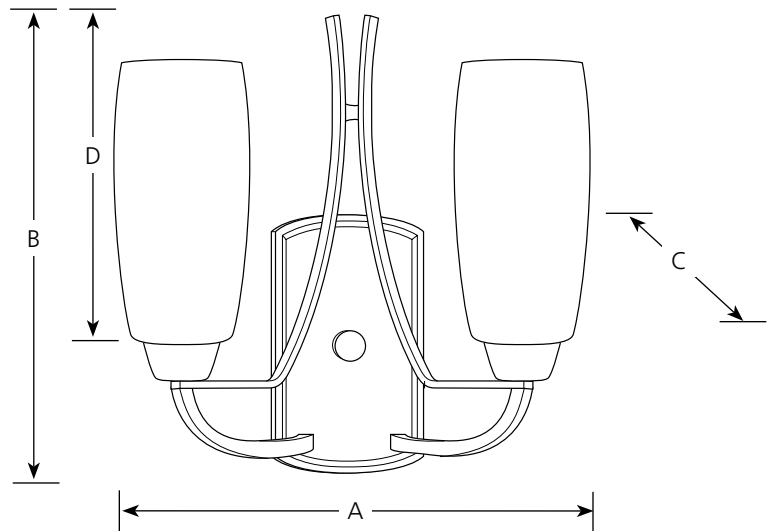

Specifications:

General

- Etched tulip shaped glass shades: 3-7/8" dia. x 8-1/8" ht., 1-5/8" center hole
- Flat steel arms
- Brushed Nickel (-09) is plated
- Antique Bronze (-20) is hand painted
- Steel construction
- Companion chandelier, hall & foyer,

pendant, and close to ceiling,

Mounting

- Wall mounted
- Backplate covers a standard 4" recessed octagonal outlet box: 7-3/4" dia. x 4-1/2" ht. x 3/4" deep
- Mounting strap for outlet box included

Electrical

- Phenolic candelabra based sockets
- Pre-wired

Labeling

- UL-CUL damp location listed