



Incandescent

Motion Sensor
Energy Star

Outdoor

Type _____
-31
P5662

Catalog No.	Finish		Lamping	Dimensions (Inches)			
	Black			A	B	C	D
P5662	-31		1 (m) 100w	5-1/2	13	6-1/2	6

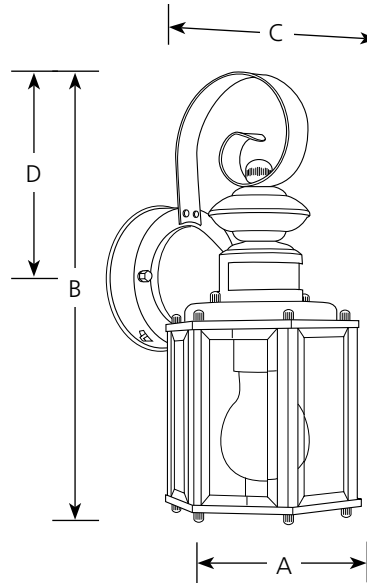

Specifications:

General

- Beveled clear glass panels
- Scroll decorative element
- Painted black (-31) finish
- Energy star certified
- Brass construction

Mounting

- Wall mounted outdoor
- Covers standard recessed octagonal outlet box: backplate 4-1/2" dia. x 1-1/8" d
- Mounting strap for outlet box included

Electrical

- Ceramic medium based sockets
- Motion sensor can be set to leave unit on for 5 to 15 minutes after motion ceases
- Integral photocell turns unit off during daytime
- Pre-wired

Labeling

- UL-CUL "Wet Location" listed



Progress Lighting
701 Millennium Blvd.
Greenville, South Carolina
29607

www.progresslighting.com

Rev. 4/10