

THIS SPACE FOR DESIGNER/ ENGINEER APPROVAL

Job/Customer _____ Date _____ Contractor _____

Model Specified _____ Qty _____ Approved By _____

Designer/Engineer _____ Date _____ Contractor's PO# _____

Submitted by _____ Date _____ Other _____

0382 Series FULL PORT PVC BALL VALVES FITS BOTH SCHEDULE 40 & 80 PIPE SOCKET ENDS (WHITE) ISO 9001:2000

ITEM #	SIZE	P/CARTON	P/CASE	A	B	C	D
03822	1/2"	1	24	1/2	3 3/16	1 7/8	2 3/4
03823	3/4"	1	24	3/4	3 5/8	2 1/16	3 1/16
03824	1"	1	24	1	4	2 3/8	3 9/16
03825	1 1/4"	1	12	1 1/4	4 7/16	2 11/16	4 7/16
03826	1 1/2"	1	12	1 1/2	5 3/16	2 7/8	4 1/2
03827	2"	1	12	2	6 1/16	3 1/2	5 3/16
03828	2 1/2"	1	16	2 1/2	8 1/2	4 3/8	7 1/2
03829	3"	1	6	3	8 1/2	4 1/2	7 1/2
03830	4"	1	4	4	11 1/2	5 13/16	10 1/8
03831	6"	1	1	6	5 3/4	7	11 3/8



NO.	DESCRIPTION	MATERIAL
1	BODY	PVC (WHITE)
2	SEATS	TPE
3	BALL/STEM	PVC
4	O-RING	FKM
5	HANDLE	ABS (RED)
6	HANDLE CAP	ABS (RED)

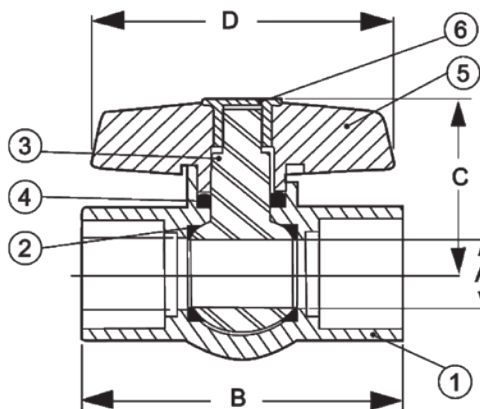

1/2" - 2" VALVES MAX TEMP 113 °F - 230 PSI
2 1/2" - 6" VALVES MAX TEMP 113 °F - 150 PSI

Specifications: Designed for residential and commercial use with water. This approved Webstone Valve is actuated by a blowout proof one piece design ball/stem. Not suitable for use with potable water. Ideal for irrigation and swimming pool applications. Fits both schedule 40 and schedule 80 pipe.

Webstone Company, Inc.
www.webstonevalves.com

Quality and Commitment Since 1954

Tel: (800) 225-9529 • Fax (800) 336-5133

Webstone product specifications in U.S. customary units are approximate and are provided for reference only. Webstone reserves the right to change or modify product design, construction, specifications or materials without prior notice and without incurring any obligation to make such changes and modifications on Webstone products previously or subsequently sold.

0382spec_060209