

# THIS SPACE FOR DESIGNER/ ENGINEER APPROVAL

Job/Customer _____	Date _____	Contractor _____
Model Specified _____	Qty _____	Approved By _____
Designer/Engineer _____	Date _____	Contractor's PO# _____
Submitted by _____	Date _____	Other _____

## 4044 Series

Isolator® E-X-P™

Tankless Water Heater Service Valve Kit

Hot & Cold Set Full Port Forged Brass Ball Valves  
w/ Hi-Flow Hose Drains & Pressure Relief Valve Outlet

IPS Union x IPS

600 WOG



ITEM #	SIZE	P/CARTON	P/CASE	A	B	C	D	E	F	G	H
40443	3/4"	1	8	3/4	4 7/8	1 3/4	1 7/8	2 7/8	3/4	3/4	-
40444	1"	1	8	1	5 3/8	2 1/8	2	3 5/16	3/4	3/4	-
RESIDENTIAL PRESSURE RELIEF VALVE (150 PSI/200,000 BTU)											
40443PR	3/4"	1	8	3/4	4 7/8	1 3/4	1 7/8	2 7/8	3/4	3/4	3/4
40444PR	1"	1	8	1	5 3/8	2 1/8	2	3 5/16	3/4	3/4	3/4
COMMERCIAL PRESSURE RELIEF VALVE (150 PSI/2,703,000 BTU) & 3/4" CLOSE NIPPLE											
40443PR2	3/4"	1	8	3/4	4 7/8	1 3/4	1 7/8	2 7/8	3/4	3/4	3/4
40444PR2	1"	1	8	1	5 3/8	2 1/8	2	3 5/16	3/4	3/4	3/4



TEMP °F	WOG
100	600
150	490
180	478

PATENTS PENDING

Complies w/  
NSF/ANSI 61-8



¾ SERVICE VALVE KITS INCLUDES:  
PRESSURE RELIEF VALVE  
cUPC LISTED HOT & COLD VALVES  
(PART # 40653 & 40663)

NO.	DESCRIPTION	MATERIAL
1	BODY	BRASS
2	END CAP	BRASS
3	SEAT	PTFE
4	BALL	BRASS HCP
5	STEM	BRASS
6	STEM SEAL	PTFE
7	PACKING GLAND	BRASS
8	HANDLE NUT	STAINLESS STEEL
9	WING STYLE "T" HANDLE	STAINLESS STEEL
10	HANDLE JACKET	VINYL
11	LOCK WASHER	STAINLESS STEEL
12	UNION WASHER	EPDM
13	COLORLED INSULATOR RING	ABS
14	UNION NUT	BRASS
15	UNION FITTING	BRASS
16	RETAINING SEATS	PTFE
17	DRAIN VALVE HANDLE	ENAMEL COATED ALUMINUM
18	DRAIN VALVE HANDLE SCREW	BRASS
19	RETAINING NUT	BRASS
20	CAP & STRAP	BRASS W/ EPDM HOSE WASHER

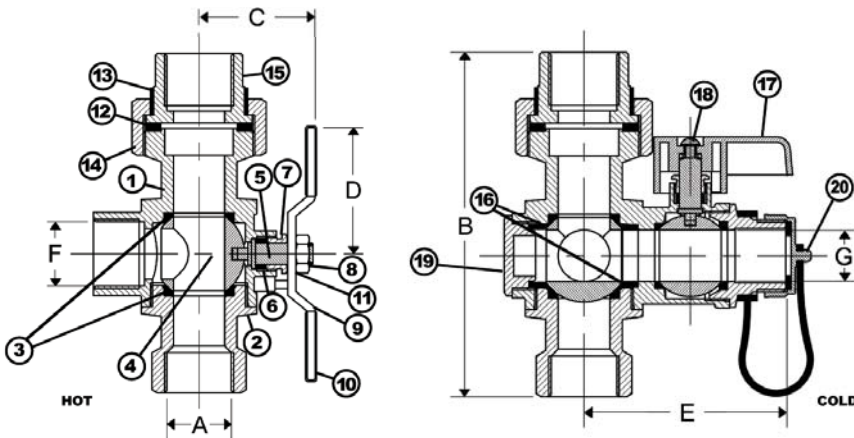

Included w/ 4044PR	Included w/ 4044PR2
 Residential Pressure Relief Valve (150 PSI/200,000 btu)	 Commercial Pressure Relief Valve (150 PSI/200,000 btu) & 3/4" Close Nipple

Specifications: Designed for residential, commercial or industrial use with water, oil or gas. This approved Webstone valve features an adjustable packing nut and safety feature that prevents flow from the drain valve when the main valve is in the open position. Threaded ends comply with ANSI B1.20.1. cUPC certification applies to 3/4" models only.

**Webstone** Company, Inc.  
www.webstonevalves.com

Quality and Commitment Since 1954

Tel: (800) 225-9529 • Fax (800) 336-5133

Webstone product specifications in U.S. customary units are approximate and are provided for reference only. Webstone reserves the right to change or modify product design, construction, specifications or materials without prior notice and without incurring any obligation to make such changes and modifications on Webstone products previously or subsequently sold.

4044spec\_082709